

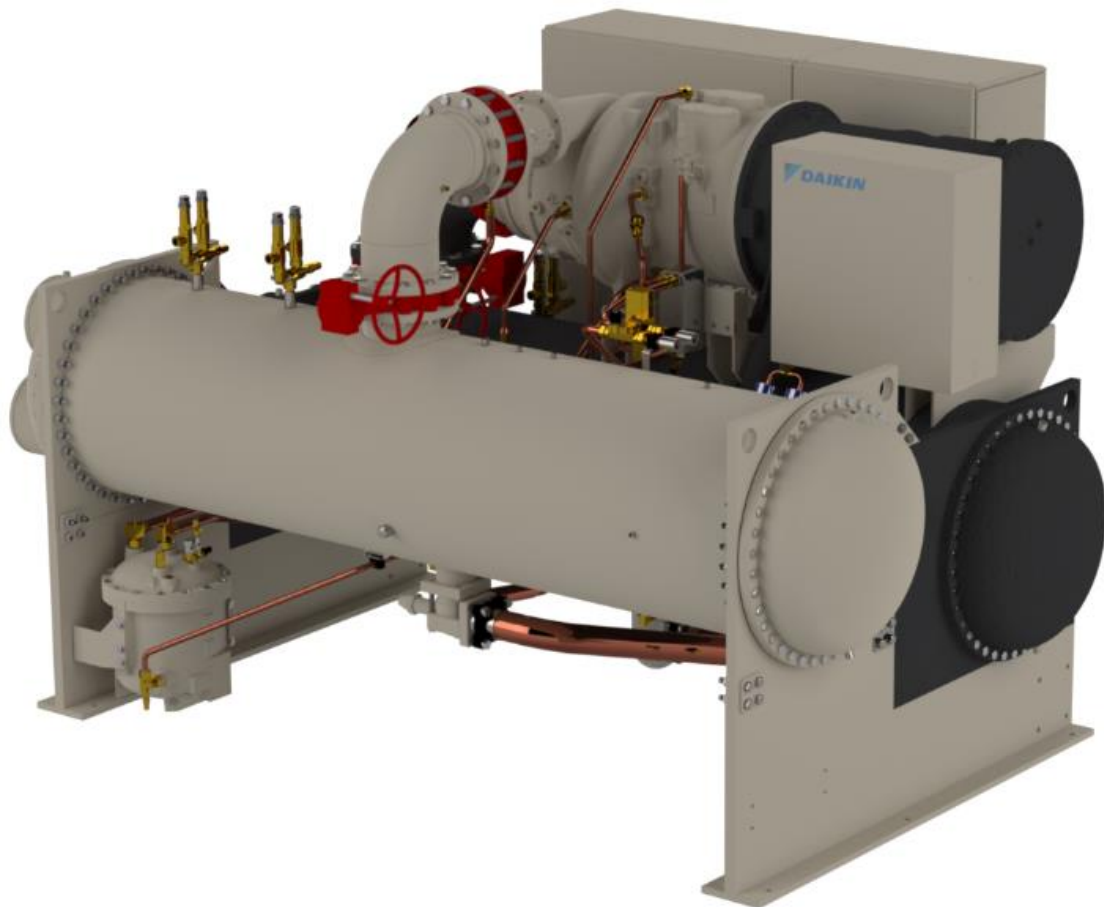
**DAIKIN**



REV	03
Date	04/2022
Supersedes	D-EIMWC00803-21_02EN

**Installation, Operation and Maintenance Manual  
D-EIMWC00803-21\_03EN**

**DWSC – Vintage C**



# CONTENTS

<b>1</b>	<b>INTRODUCTION .....</b>	<b>10</b>
1.1	Precautions against residual risks.....	11
1.2	Description .....	12
1.3	Information about refrigerant R1234ze(E).....	12
1.4	Safety Installation.....	13
1.4.1	Additional guidelines for safe use of R1234ze(E) for equipment located in the open air .....	13
1.4.2	Additional guidelines for safe use of R1234ze (E) for equipment located in a machinery room.....	13
<b>2</b>	<b>RECEIVING THE UNIT .....</b>	<b>15</b>
<b>3</b>	<b>OPERATING LIMITS .....</b>	<b>16</b>
3.1	Storing Storage .....	16
3.2	Operation .....	16
<b>4</b>	<b>MECHANICAL INSTALLATION.....</b>	<b>17</b>
4.1	Safety.....	17
4.2	Positioning and assembly .....	17
4.3	System water volume.....	17
4.4	Condensation control with evaporative cooling tower .....	17
4.5	Condensation control with well water.....	18
4.6	Water piping.....	19
4.6.1	Water Pumps .....	19
4.6.2	Vessel Drains at Start-up.....	19
4.6.3	Evaporator and Condenser Water Piping .....	19
4.6.4	Important Note on Welding .....	19
4.6.5	Flow Switch.....	19
4.6.6	Cooling Towers .....	20
4.7	Water treatment.....	20
4.8	Field Insulation Guide .....	21
4.9	PHYSICAL DATA AND WEIGHTS .....	23
4.9.1	Evaporator .....	23
4.9.2	Condenser .....	23
4.9.3	Pumpdown.....	23
4.9.4	Compressor .....	25
4.10	Oil Coolers .....	25
4.11	Oil Heater.....	27
4.12	Relief Valves .....	27
4.12.1	Refrigerant Vent Piping.....	27
<b>5</b>	<b>ELECTRICAL INSTALLATION .....</b>	<b>28</b>
5.1	General specifications.....	28
5.2	Electrical supply.....	28
5.3	Power wiring .....	28
5.4	Control power wiring.....	29
5.5	Flow Switches.....	29
5.6	Control Panel Switches.....	29
5.7	Cable requirements.....	29
5.8	Phase unbalance .....	30
<b>6</b>	<b>PRESTART SYSTEM CHECKLIST .....</b>	<b>31</b>
<b>7</b>	<b>OPERATION.....</b>	<b>32</b>
7.1	Operator's responsibilities.....	32
7.2	Standby Power.....	32
7.3	Lubrication System .....	32
7.4	Hot Gas Bypass.....	33
7.5	Condenser Water Temperature .....	33
<b>8</b>	<b>MAINTENANCE .....</b>	<b>34</b>
8.1	Pressure/Temperature Chart .....	34
8.2	Routine Maintenance .....	35
8.2.1	Lubrication .....	35
8.2.2	Changing Oil Filters .....	37
8.2.3	Refrigerant Cycle .....	37
8.2.4	Electrical System .....	37
8.2.5	Compressor Maintenance.....	38
8.2.6	Flanged joints disassembly.....	38
8.2.7	Cleaning and Preserving.....	39
8.3	Annual Shutdown.....	39
8.4	Annual Startup .....	39
8.5	Repair of System .....	39
8.5.1	Pressure Relief Valve Replacement .....	39
8.5.2	Pumping Down.....	39

8.5.3	Pressure Testing.....	40
8.5.4	Leak Testing .....	40
8.5.5	Evacuation .....	40
8.5.6	Charging the System .....	40
<b>9</b>	<b>MAINTENANCE SCHEDULE.....</b>	<b>41</b>
<b>10</b>	<b>SERVICE PROGRAMS AND WARRANTY STATEMENT.....</b>	<b>43</b>
<b>11</b>	<b>PERIODIC CHECKS AND COMMISSIONING OF PRESSURE EQUIPMENT .....</b>	<b>43</b>
<b>12</b>	<b>DISPOSAL.....</b>	<b>43</b>
<b>13</b>	<b>IMPORTANT INFORMATION REGARDING THE REFRIGERANT USED.....</b>	<b>44</b>
13.1	Factory and Field charged units instructions.....	44
<b>14</b>	<b>ANNEX A: ELECTRICAL PANEL.....</b>	<b>45</b>
14.1	Acceptance of the Product .....	45
14.1.1	Checks .....	45
14.2	ABBREVIATIONS .....	45
14.3	Electrical panel Nomenclature For C Series.....	46
14.4	Vfds And Distortion .....	46
14.4.1	VFD Line Harmonics .....	46
14.4.2	Current Harmonics .....	46
14.4.3	Voltage Harmonics.....	46
14.4.4	EMI and RFI Filter .....	46
14.5	SAFETY .....	48
14.5.1	Avoid electrocution.....	48
14.5.2	Residual risks.....	49
14.6	HANDLING AND TRANSPORT .....	49
14.7	MECHANICAL INSTALLATION .....	50
14.7.1	Shipping.....	50
14.7.2	Cabinet Handling and Lifting .....	50
14.7.3	Positioning and assembly .....	51
14.7.4	Minimum space requirements .....	51
14.8	CONTROL PANEL GENERAL SPECIFICATIONS .....	52
14.8.1	Product Identification.....	52
14.8.2	Specification.....	52
14.8.3	Directives and Standards .....	52
14.9	SOFT STARTER GENERAL SPECIFICATIONS .....	54
14.9.1	Product Identification.....	54
14.9.2	Specification.....	54
14.9.3	Directives and Standards .....	55
14.10	VFD GENERAL SPECIFICATIONS .....	56
14.10.1	Product Identification.....	56
14.10.2	Individuation of Parts.....	57
14.10.3	Specification.....	58
14.10.4	Directives and Standards .....	59
14.10.5	VFD terminals .....	60
14.10.6	Piping Connections .....	60
14.11	VFD WITH ACTIVE FILTER GENERAL SPECIFICATIONS.....	61
14.11.1	Product Identification.....	61
14.11.2	Individuation of Parts.....	62
14.11.3	Specification.....	64
14.11.4	Directives and Standards .....	65
14.11.5	VFD terminals .....	66
14.11.6	Piping Connections .....	66
14.12	Maintenance.....	67
14.12.1	Ordinary maintenance.....	67
14.12.2	Extraordinary maintenance .....	68
14.13	VFD COMMUNICATION .....	68
14.13.1	Modbus RTU Configuration.....	68
14.13.2	Modbus Parameters .....	69

## LIST OF FIGURES

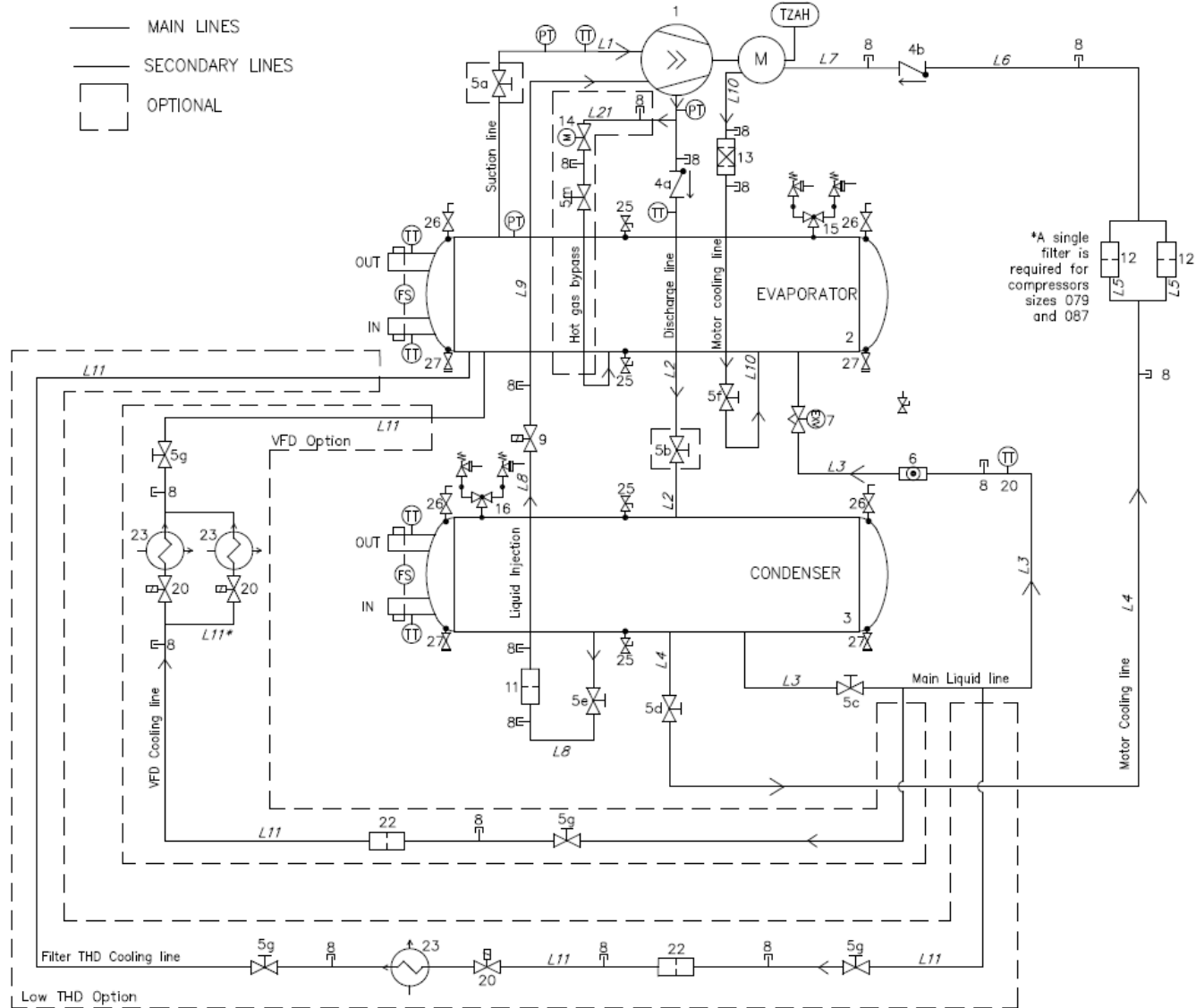
Fig. 1 - Typical oil circuit.....	6
Fig. 2 - Description of the labels applied to the electrical panel.....	8
Fig. 3 - - Description of the labels applied to the Motor Terminal Box .....	8
Fig. 4 - Label on compressor.....	9
Fig. 5 - DWSC Major Component Locations .....	15
Fig. 6 - Condenser control scheme with cooling tower.....	18
Fig. 7 - Condensation control scheme with well water .....	18
Fig. 8 - Flow switch mounting.....	19
Fig. 9 - Oil Cooler Piping Across Chilled Water Pump .....	26
Fig. 10 - Oil Cooler Piping With City Water .....	26
Fig. 11 - DWSC, Oil cooling connections .....	26
Fig. 12 - Condenser 3-Way Valve .....	27
Fig. 13 - Label: Risk of Electric shock .....	48
Fig. 14 - Angle to respect for lifting operation.....	50
Fig. 15 - Lifting the VFD .....	51
Fig. 16 - Minimum space requirements for VFD.....	51
Fig. 17 - Control panel identification Label .....	52
Fig. 18 - Electrical Panel with soft starter identification Label.....	54
Fig. 27 - Electrical Panel identification Label.....	61
Fig. 28 - VFD with active filter panel parts.....	62
Fig. 29 - VFD replaceable parts highlighted .....	63

## LIST OF TABLES

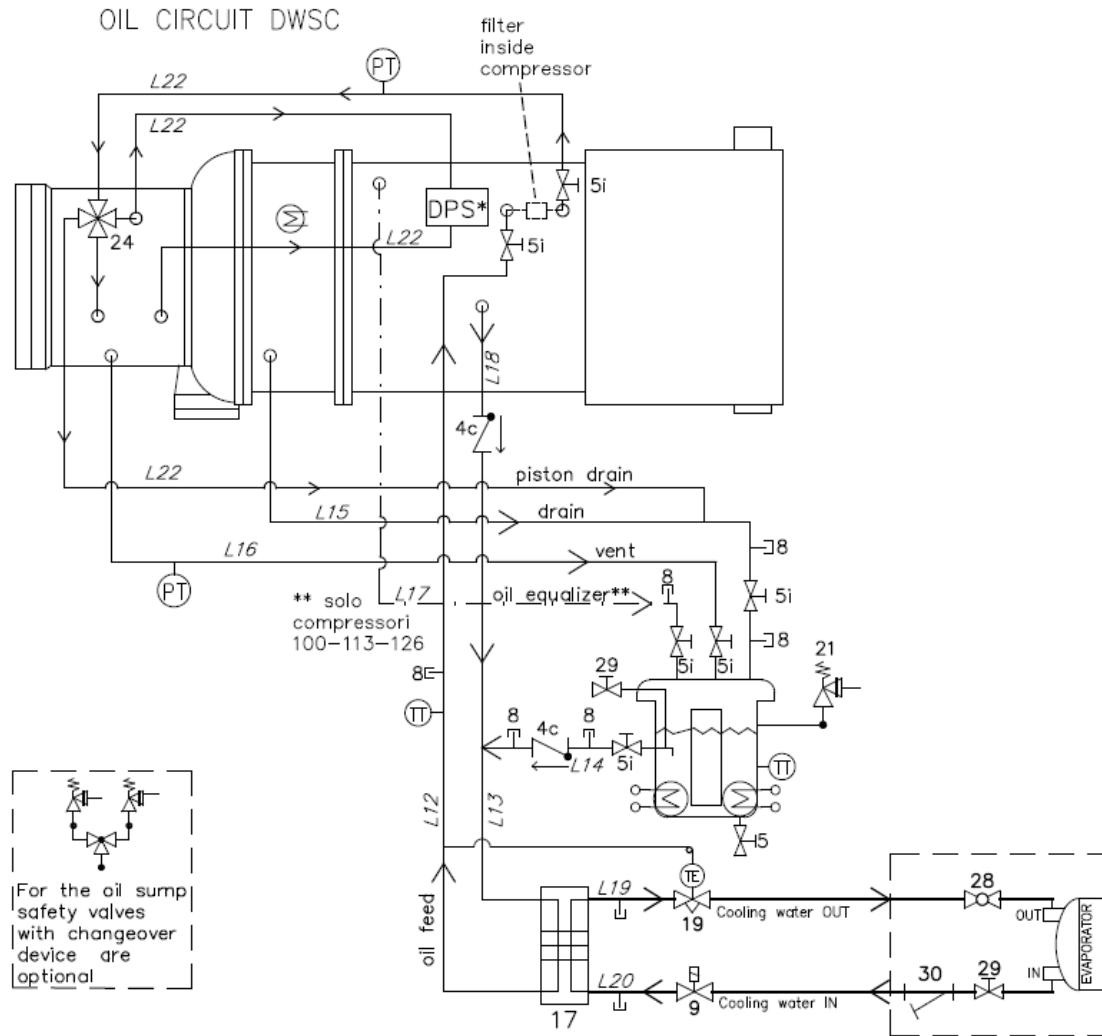
Table 1 - Flow switch rates.....	20
Table 2 - Acceptable water quality limits .....	20
Table 3 - Evaporator Data .....	23
Table 4 - Condenser Data .....	23
Table 5 - Compressor Weights.....	25
Table 6 - DWSC, Oil cooler Data .....	25
Table 7 - Cooling Water connection sizes .....	26
Table 8 - Table 1 of EN60204-1 Point 5.2 .....	29
Table 9 - Approved Polyolester oils for R134a units .....	32
Table 10 - Upper Limit For Wear Metals And Moisture In Polyolester Oils In Daikin Centrifugal Chillers .....	37

**Fig. 1 - Typical refrigerant circuit**

**Water inlet and outlet are indicative. Please refer to the machine dimensional diagrams for exact water connections**



**Fig. 1 - Typical oil circuit**

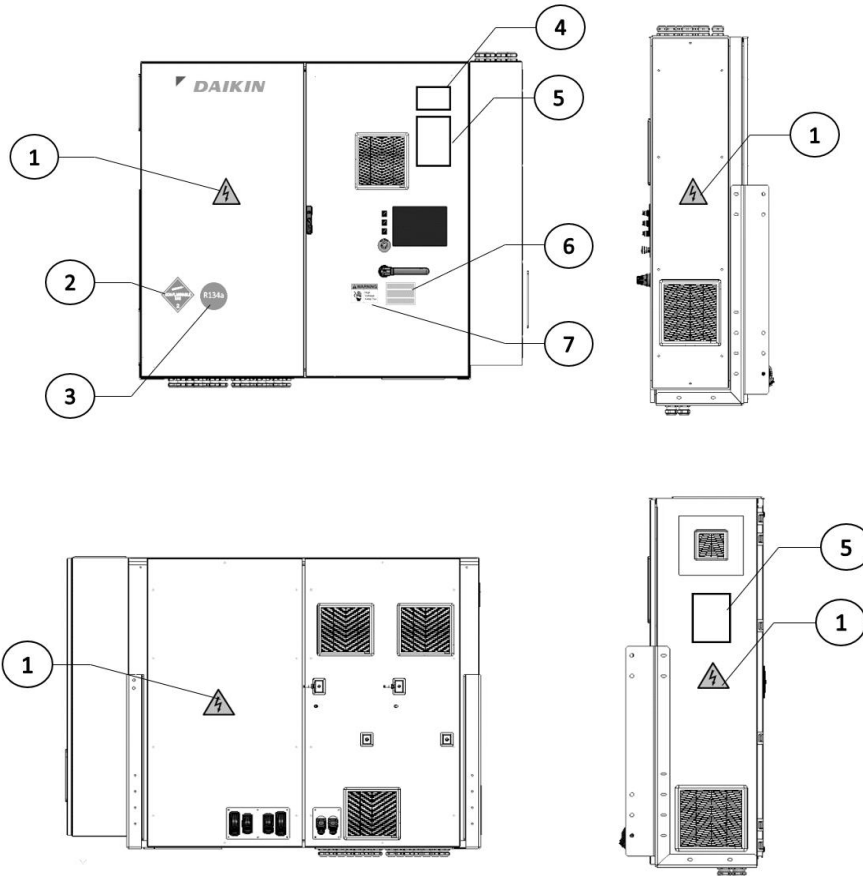


LEGEND	
ID	DESCRIPTION
1	CENTRIFUGAL COMPRESSOR
2	EVAPORATOR
3	CONDENSER
4	CHECK VALVE
5	SHUT-OFF VALVE*
6	SIGHT GLASS
7	ELECTRONIC EXPANSION VALVE
8	PLUGGED FITTING
9	SOLENOID VALVE
11	FILTER
12	DRYING FILTER #1
13	DRYING FILTER #2
14	MOTOR ACUATED VALVE
15	PRESSURE RELIEF VALVE Pset= 13,7 (10,5) bar
16	PRESSURE RELIEF VALVE Pset=13,7 bar
17	OIL HEAT EXCHANGER
18	OIL PUMP
19	WATER VALVE
20	VFD SOLENOID VALVE
21	PRESSURE RELIEF VALVE Pset= 13,7 bar
22	VFD FILTER
23	VFD HEAT EXCHANGER
24	4WAY VALVE (OIL CIRCUIT)
25	ACCESS FITTING
26	AIR VENT (WATER SIDE)
27	DRAIN (WATER SIDE)
28	BALL VALVE (WATER SIDE)
29	MANUAL ACTIVATED VALVE
30	Y FILTER (WATER SIDE)
PT	PRESSURE TRANSDUCER
PZH	HIGH PRESSURE SWITCH 22,7 Bar
TZAH	HIGH TEMPERATURE SWITCH (MOTOR THERMISTOR)
PSAL	LOW PRESSURE LIMITER (CONTROLLER FUNCTION)
TT	TEMPERATURE TRANSDUCER
DPS	DIFFERENTIAL PRESSURE SWITCH (* N° 2 for VFD units)
FS	FLOW SWITCH
L1	SUCTION LINE (Evaporator->Compressor)
L2	DISCHARGE LINE (Compressor->Condenser)
L3	MAIN LIQUID LINE (Condenser->Evaporator)
L4	MOTOR COOLING LINE #1 (Cond->Filter)
L5	MOTOR COOLING LINE #2 (Filter)
L6	MOTOR COOLING LINE #3 (Filter->Checkvalve)
L7	MOTOR COOLING LINE #4 (Check valve->Motor)
L8	LIQUID INJECTION #1 (Condenser->Solenoid valve)
L9	LIQUID INJECTION #2 (Solenoidvalve->Compressor)
L10	MOTOR COOLING LINE #5 (Motor->Evaporator)
L11	THD/VFD COOLING LINE (*n° 2 lines L11 for doubleVFD)
L12	OIL FEED LINE #1 (Oil Cooler->Compressor)
L13	OIL FEED LINE #2
L14	OIL FEED LINE #3
L15	DRAIN LINE (Compressor->Oil Tank)
L16	VENT LINE (Compressor->Oil Tank)
L17	OIL EQUALIZER LINE (Compressor->Oil Tank)
L18	THURST PUMP LINE (Compressor->Checkvalve)
L19	WATER LINE OUT
L20	WATER LINE IN
L21	HOT GAS BYPASS LINE
L22	OIL LINE



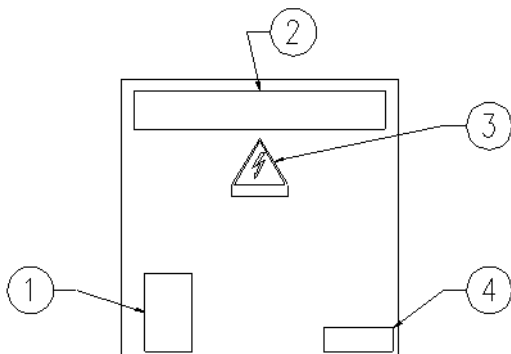
**All the shut off valves (ID 5) are only service valves and they shall not be closed except for maintenance operations.**

**Fig. 2 - Description of the labels applied to the electrical panel**



<b>1)</b> Electrical hazard symbol	<b>4)</b> Control panel code
<b>2)</b> Non flammable gas symbol	<b>5)</b> Unit nameplate data
<b>3)</b> Gas type	<b>6)</b> Unit characteristics technical

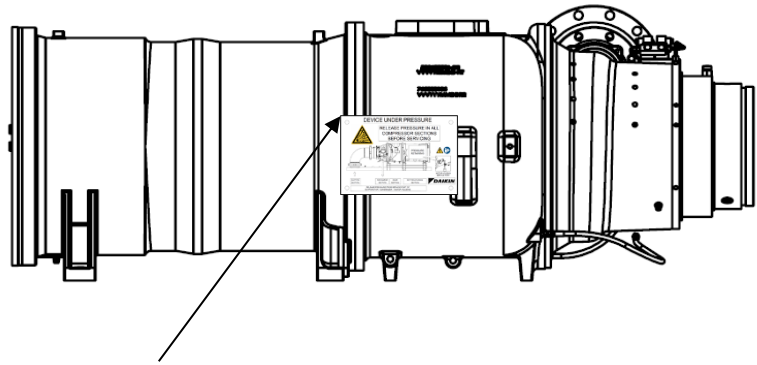
**Fig. 3 - - Description of the labels applied to the Motor Terminal Box**



<b>1)</b> Terminal box fixing	<b>3)</b> Electrical hazard symbol
<b>2)</b> Manufacturer's logo	<b>4)</b> Terminal connection



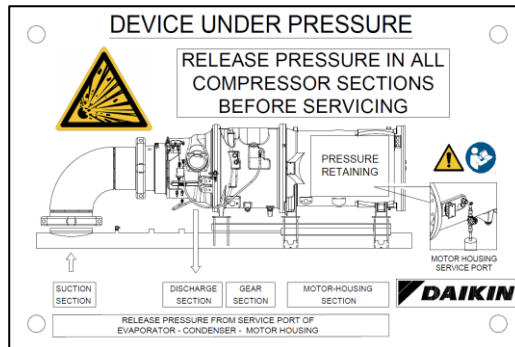
Fig. 4 - Label on compressor



DEVICE UNDER PRESSURE

RELEASE PRESSURE IN ALL COMPRESSOR SECTIONS BEFORE SERVICING

For more detail see par. 13.2.5



## 1 INTRODUCTION

---

**This manual is an important supporting document for qualified personnel but it is not intended to replace such personnel.**

---



**The units described in the present manual represent a valuable investment. Maximum care should be taken to ensure correct installation and appropriate working conditions of the units. THIS MANUAL, WIRING DIAGRAMS AND DIMENSIONAL DRAWINGS MUST BE CONSIDERED ESSENTIALS, KEEP A COPY OF THESE DOCUMENTS ALWAYS AVAILABLE INSIDE THE UNIT. Installation and maintenance must be performed by qualified and specifically trained personnel only. Correct maintenance of the unit is indispensable for its safety and reliability. Manufacturer's service centres are the only having adequate technical skill for maintenance.**

---



**READ THIS DOCUMENT IN ITS ENTIRETY BEFORE BEGINNING ANY WORK ON THE UNIT. ALL FEDERAL, STATE, LOCAL ENVIRONMENTAL AND SAFETY REGULATIONS INCLUDING DAIKIN SAFETY RULES MUST BE FOLLOWED.**

**All appropriate Personal Protective Equipment ("PPE") must be used, and a Job Hazard Analysis ("JHA") must be completed, before beginning any work on the unit. Technicians performing this work must be properly trained on Daikin DWSC Centrifugal equipment.**

**Important Note: In case of any procedure requires accessing the refrigerant circuit of these units, remember that refrigerant is under pressure and oils are contained in these circuits. Ensure that all appropriate pump-down or pump-out service valves are in the correct position, open or closed as required and holding. Solenoid valves and expansion valves can trap refrigerant and oils, these devices must be operated manually to release any trapped gases and oils while in pump-down or pump-out operation. All refrigerant lines and components of the unit must be evacuated to at least 30 kPa vacuum and verified before opening any charging valves, venting schrader valves or testing ports. These devices must be open and vented while accessing the refrigerant system. In some cases, cross connection lines may be required to ensure recovery of all refrigerant in all sections of the affected system or components.**

---



**All units are delivered from factory as complete sets which include wiring diagrams and dimensional drawings with size, weight and features of each model.**

**In case of any discrepancy between this manual and the two aforesaid documents, please refer to the wiring diagram and dimensional drawings.**

### **Power Wiring**

- **Qualified and licensed electricians must perform wiring. Shock hazard exists.**
- **Connections to terminals must be made with copper lugs and copper wire.**
- **Before any installation and connection work, the system must be switched off and secured. After switching off the unit, when an inverter is installed, the intermediate circuit capacitors of the inverter are still charged with high voltage for 5 minutes.**
- **Before taking any action, switch off the main switch to cut off electricity to the machine.**

**When the machine is off but the disconnecting switch is in the closed position, unused circuits are always live.**

**Never open the terminal board box of the compressors unless the main switch of the machine has been switched off.**

- **The units of the series can be provided with non-linear high power electrical components (inverters) which introduce higher harmonics, can cause considerable leakage to earth, (higher than 300 mA). The electricity supply system protection must take the above values into account.**
- 



**Before starting the installation of the unit, please read this manual carefully. Starting up the unit is absolutely forbidden if all instructions contained in this manual are not clear.**

**Commissioning of the unit (first start up) must be performed by Daikin representative. It is absolutely forbidden to remove all the protections of the moving parts of the unit.**

---

---

***If the unit mounts suction and discharge valves they need to be secured in open position when the unit is installed, by means of a lead seal or equivalent. This to avoid they are put in closed position. The use of this valve is intended for compressor maintenance.***

***If refrigerant charge of the unit is more than 500 kg it is necessary to install gas sensor on water circuit to catch an eventual gas leakage.***

***Verify that the unit has not zero pressure in the refrigerant circuit before charging water into the heat exchangers. In case there is not pressure in the refrigerant circuit, do not charge water.***

***Do not use oxygen or a mixture of refrigerant and air to build up pressure as explosion can occur causing serious personal injury.***

---

## **1.1 Precautions against residual risks**

1. Install the unit according to the instructions set out in this manual.
2. Regularly carry out all the maintenance operations foreseen in this manual.
3. Wear protective equipment (gloves, eye protection, hard hat, etc.) suited to the work in hand; do not wear clothes or accessories that can get caught or sucked in by flows of air; tie back long hair before entering the unit.
4. Before opening the machine panelling make sure that it is firmly hinged to the machine.
5. The fins on heat exchangers and the edges of metal components and panels can cause cuts.
6. Do not remove the guards from mobile components while the unit is operating.
7. Make sure that mobile component guards are fitted correctly before restarting the unit.
8. Fans, motors and belts drives might be running: before entering, always wait for these to stop and take appropriate measures to prevent them from starting up.
9. The surfaces of the machine and pipes can get very hot or cold and cause the risk of scalding.
10. Never exceed the maximum pressure limit (PS) of the water circuit of the unit.
11. Before removing parts on the pressurised water circuits, close the section of the piping concerned and drain the fluid gradually to stabilise the pressure at the atmospheric level.
12. Do not use your hands to check possible refrigerant leaks.
13. Disable the unit from the mains using the main switch before opening the control panel.
14. Check that the unit has been grounded correctly before starting it.
15. Install the machine in a suitable area; in particular, do not install it outdoors if it is intended for use indoors.
16. Do not use cables with inadequate sections nor extension cord connections, even for very short periods or emergencies.
17. For units with power correction capacitors, wait 5 minutes after removing the electric power supply before accessing the inside of the switch board.
18. If the unit is equipped with compressors with integrated inverter, disconnect it from the mains and wait a minimum of 20 minutes before accessing it to carry out maintenance: residual energy in the components, which takes at least this length of time to dissipate, poses the risk of electrocution.
19. The unit contains pressurised refrigerant gas: the pressurised equipment must not be touched except during maintenance, which must be entrusted to qualified and authorised personnel.
20. Connect up the utilities to the unit following the indications set out in this manual and on the panelling of the unit itself.
21. In order to avoid an environmental risk, make sure that any leaking fluid is collected in suitable devices in accordance with local regulations.
22. If a part needs to be dismantled, make sure it is correctly re-assembled before starting the unit.
23. When the rules in force require the installation of fire-fighting systems near the machine, check that these are suitable for extinguishing fires on electrical equipment and on the lubricating oil of the compressor and the refrigerant, as specified on the safety data sheets of these fluids.
24. When the unit is equipped with devices for venting overpressure (safety valves): when these valves are triggered, the refrigerant gas is released at a high temperature and speed; prevent the release of gas from harming people or objects and, if necessary, discharge the gas according to the provisions of EN 378-3 and the local regulations in force.
25. Keep all the safety devices in good working order and check them periodically according to the regulations in force.
26. Keep all lubricants in suitably marked containers.
27. Do not store inflammable liquids near the unit.
28. Solder or braze only empty pipes after removing all traces of lubricant oil; do not use flames or other heat sources in the vicinity of pipes containing refrigerant fluid.
29. Do not use naked flames near the unit.
30. The machinery must be installed in structures protected against atmospheric discharge according to the applicable laws and technical standards.
31. Do not bend or hit pipes containing pressurised fluids.
32. It is not permitted to walk or rest other objects on the machines.
33. The user is responsible for overall evaluation of the risk of fire in the place of installation (for example, calculation of the fire load).
34. During transport, always secure the unit to the bed of the vehicle to prevent it from moving about and overturning.

35. The machine must be transported according to the regulations in force taking into account the characteristics of the fluids in the machine and the description of these on the safety data sheet.
36. Inappropriate transport can cause damage to the machine and even leaking of the refrigerant fluid. Before start-up, the machine must be checked for leaks and repaired accordingly.
37. The accidental discharge of refrigerant in a closed area can cause a lack of oxygen and, therefore, the risk of asphyxiation: install the machinery in a well ventilated environment according to EN 378-3 and the local regulations in force.
38. The installation must comply with the requirements of EN 378-3 and the local regulations in force; in the case of installations indoors, good ventilation must be guaranteed and refrigerant detectors must be fitted when necessary.

## **1.2 Description**

Daikin Centrifugal Water Chillers are complete, self-contained, automatically controlled fluid chilling units. Each unit is completely assembled and factory tested before shipment. Models DWSC are cooling or heating units.

In the DWSC, each unit has one compressor connected to a condenser and evaporator. Information in this manual referring to all DWSC units except where specifically noted.

The chillers use refrigerant R-134a, R-513A and R-1234ze to reduce the size and weight of the package compared to negative pressure refrigerants, and since these refrigerants operates at a positive pressure over the entire operation range, no purge system is required.

The controls are pre-wired, adjusted and tested. Only normal field connections such as piping, electrical and interlocks, etc. are required, thereby simplifying installation and increasing reliability. Most necessary equipment protection and operating controls are factory installed in the control panel.

The basic sizes of units are the 079, 087, 100, 113 and 126. They provide a cooling capacity range from 750 kW to 4500 kW.

## **1.3 Information about refrigerant R1234ze(E)**

This product can be equipped with refrigerant R1234ze(E) which has minimal impact to the environment, thanks to its low value of Global Warming Potential (GWP). R1234ze(E) refrigerant is classified by European Directive 2014/68/EU as a Group 2 (non-dangerous) substance, as it is nonflammable at standard ambient temperature and non-toxic. Due to this, no special precautions are required for storage, transport and handling.

Daikin Applied Europe S.p.A. products comply with applicable European Directives and refer for unit design to product Standard EN378:2016 and industrial Standard ISO5149. Local authorities approval should be verified referring to European Standard EN378 and/or ISO 5149 (where R1234ze(E) is classified A2L – Mildly flammable gas).

**Physical characteristics of refrigerant R1234ze (E)**

Safety Class	A2L
PED Fluid Group	2
Practical limit (kg/m <sup>3</sup> )	0.061
ATEL/ ODL (kg/m <sup>3</sup> )	0.28
LFL (kg/m <sup>3</sup> ) @ 60 °C	0.303
Vapour density @25 °C, 101.3 kPa (kg/m <sup>3</sup> )	4.66
Molecular Mass	114.0
Normal Boiling Point (°C)	-19
GWP (100 yr ITH)	7
GWP (ARS 100 yr ITH)	<1
Auto Ignition Temperature (°C)	368

**1.4 Safety Installation**

The chiller has to be installed in open air or machinery room (location classification III).

To ensure location classification III a mechanical vent on the secondary circuit(s) has to be installed.

Local building codes and safety standards shall be followed; in absence of local codes and standards refer to EN 378-3:2016 as a guide.

In paragraph “Additional guidelines for safe use of R1234ze(E)” there are provided additional informations that should be added to the requirements of safety standards and building codes.

**1.4.1 Additional guidelines for safe use of R1234ze(E) for equipment located in the open air**

Refrigerating systems sited in the open air shall be positioned to avoid leaked refrigerant flowing into a building or otherwise endangering people and property.

The refrigerant shall not be able to flow into any ventilation fresh air opening, doorway, trap door or similar opening in the event of a leak. Where a shelter is provided for refrigerating equipment sited in the open air it shall have natural or forced ventilation.

For refrigeration systems installed outside in a location where a release of refrigerant can stagnate e.g. below ground, then the installation shall comply with the requirements for gas detection and ventilation of machinery rooms.

**1.4.2 Additional guidelines for safe use of R1234ze (E) for equipment located in a machinery room**

When a machinery room is chosen for the location of the refrigerating equipment it shall be located in accordance with local and national regulations. The following requirements (according to EN 378-3:2016) can be used for the assessment.

- A risk analysis based on the safety concept for the refrigerating system (as determined by the manufacturer and including the charge and safety classification of the refrigerant used) shall be conducted to determine whether it is necessary to place the refrigerating system in a separate refrigeration machinery room.
- Machinery rooms should not be used as occupied spaces. The building owner or user shall ensure that access is permitted only by qualified and trained personnel doing the necessary maintenance to the machinery room or general plant.
- Machinery rooms shall not be used for storage with the exception of tools, spare parts and compressor oil for the installed equipment. Any refrigerants, or flammable or toxic materials shall be stored as required by national regulations.
- Open (naked) flames shall not be permitted in machinery rooms, except for welding, brazing or similar activity and then only provided the refrigerant concentration is monitored and adequate ventilation is ensured. Such open flames shall not be left unattended.
- A remote switching (emergency type) for stopping the refrigerating system shall be provided outside the room (near the door). A similar acting switch shall be located at a suitable location inside the room.
- All piping and ducting passing through floors, ceiling and walls of machinery room shall be sealed.
- Hot surfaces shall not exceed a temperature of 80% of the auto-ignition temperature (in °C) or 100 K less than the auto-ignition temperature of the refrigerant, whichever is higher.

Refrigerant	Auto ignition temperature	Maximum surface temperature
R1234ze	368 °C	268 °C

- Machinery rooms shall have doors opening outward and sufficient in number to ensure freedom for persons to escape in an emergency; the doors shall be tight fitting, self-closing and so designed that they can be opened from inside (antipanic system).

- Special machinery rooms where the refrigerant charge is above the practical limit for the volume of the room shall have a door that either opens directly to the outside air or through a dedicated vestibule equipped with self-closing, tight-fitting doors.
- The ventilation of machinery rooms shall be sufficient both for normal operating conditions and emergencies.
- Ventilation for normal operating conditions shall be in accordance with national regulations.
- The emergency mechanical ventilation system shall be activated by a detector(s), located in the machinery room.
  - This ventilation system shall be:
    - independent of any other ventilation system on the site;
    - provided with two independent emergency controls one located outside the machinery room, and the other inside.
  - The emergency exhaust ventilation fan shall:
    - be either in the air flow with the motor outside the airflow, or rated for hazardous areas (according to the assessment);
    - be located to avoid pressurization of the exhaust ductwork in the machinery room;
    - not cause sparks to occur if it contacts the duct material.
  - Airflow of the emergency mechanical ventilation shall be at least

$$V = 0,014 \times m^{2/3}$$

where

V is the air flow rate in m<sup>3</sup>/s;

m is the mass of refrigerant charge, in kg, in the refrigerating system with the largest charge, any part of which is located in the machinery room;

0,014 is a conversion factor.

- Mechanical ventilation shall be operated continuously or shall be switched on by the detector.
- Detector shall automatically activate an alarm, start mechanical ventilation and stop the system when it triggers.
- The location of detectors shall be chosen in relation to the refrigerant and they shall be located where the refrigerant from the leak will concentrate.
- The positioning of the detector shall be done with due consideration of local airflow patterns, accounting for location sources of ventilation and louvers. Consideration shall also be given to the possibility of mechanical damage or contamination.
- At least one detector shall be installed in each machinery room or the occupied space being considered and/or at the lowest underground room for refrigerants heavier than air and at the highest point for refrigerants lighter than air.
- Detectors shall be continuously monitored for functioning. In the case of a detector failure, the emergency sequence should be activated as if refrigerant had been detected.
- The pre-set value for the refrigerant detector at 30 °C or 0 °C, whichever is more critical, shall be set to 25 % of the LFL. The detector shall continue to activate at higher concentrations.

Refrigerant	LFL	Pre-set alarm	
R1234ze	0,303 kg/m <sup>3</sup>	0,07575 kg/m <sup>3</sup>	16500 ppm

- All electrical equipment (not only the refrigerating system) shall be selected to be suitable for use in the zones identified in the risk assessment. Electrical equipment shall be deemed to comply with the requirements if the electrical supply is isolated when the refrigerant concentration reaches 25 % of the lower flammable limit or less.
- Machinery rooms or special machinery rooms shall be **clearly marked** as such on the entrances to the room, together with warning notices indicating that unauthorized persons shall not enter and that smoking, naked light or flames are prohibited. The notices shall also state that, in the event of an emergency, only authorized persons conversant with emergency procedures shall decide whether to enter the machinery room. Additionally, warning notices shall be displayed prohibiting unauthorized operation of the system.
- The owner / operator shall keep an updated logbook of the refrigerating system.



***The optional leak detector supplied by DAE with the chiller should be used exclusively to check refrigerant leakage from the chiller itself***

## 2 RECEIVING THE UNIT

---

The unit should be inspected immediately after receipt for possible damage.

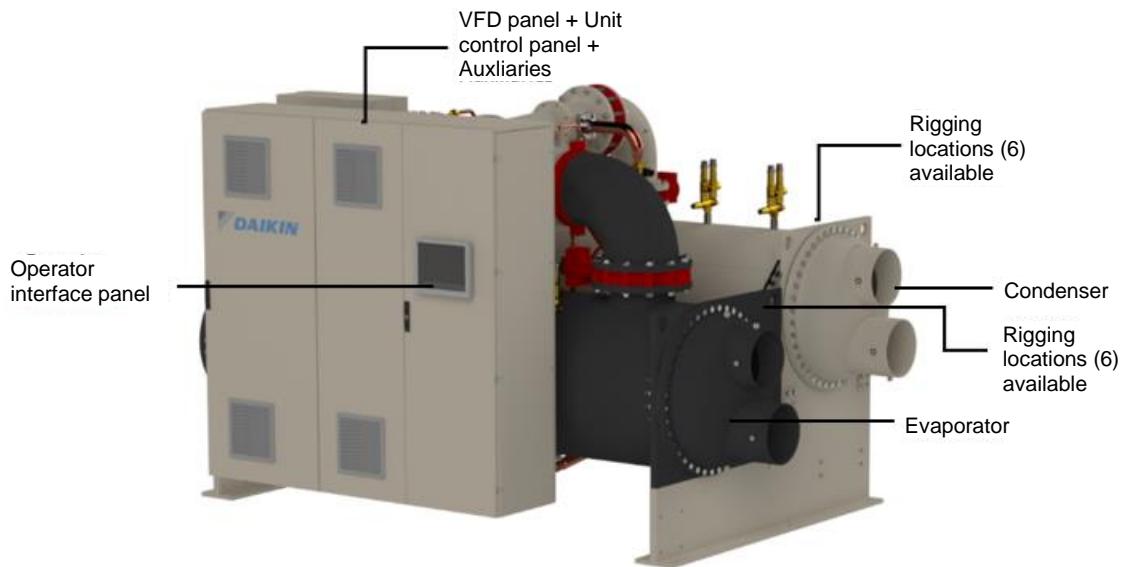
All Daikin centrifugal water chillers are shipped FOB factory and all claims for handling and shipping damage are the responsibility of the consignee.

Insulation corners from the evaporator's rigging hole locations are shipped loose and should be glued in place after the unit is finally placed. Neoprene vibration pads are also shipped loose. Check that these items have been delivered with the unit.

If so equipped, leave the shipping skid in place until the unit is in its final position. This will aid in handling the equipment. Extreme care must be used when rigging the equipment to prevent damage to the control panels or refrigerant piping. See the certified dimension drawings included in the job submittal for the center of gravity of the unit. Consult the local Daikin sales office for assistance if the drawings are not available.

The unit can be lifted by fastening the rigging hooks to the four corners of the unit where the rigging eyes are located (see Figure below). Spreader bars must be used between the rigging lines to prevent damage to the control panels, piping and motor terminal boxes.

**Fig. 5 - DWSC Major Component Locations**



***Chilled water and condenser connection location can vary. Check markings on unit or consult unit certified drawings for connection locations on specific units***

---

### 3 OPERATING LIMITS

---

#### 3.1 Storing Storage

Environmental conditions must be within the following limits:

Equipment room temperature in standby:

- Water in vessels and oil cooler: 32°F to 122°F (0°C to 50°C)
- Without water in vessels and oil cooler: 0°F to 122°F (-18°C to 50°C)
- WSC without water in vessels: 0°F to 122°F (-18°C to 50°C)

Storing below the minimum temperature may cause damage to components. Storing above the maximum temperature causes opening of safety valves. Storing in condensing atmosphere may damage electronic components.

#### 3.2 Operation

Operation is allowed within the following limits:

- Equipment room temperature, operating: 32°F to 107.6°F (0°C to 42°C)
- Maximum entering condenser water temperature, startup: design plus 5 °F (2.7°C)
- Maximum entering condenser water temperature, operating: job specific design temperature
- Minimum entering condenser water temperature, operating: see page 16.
- Minimum leaving chilled *water* temperature: 39.2°F (4.0°C)
- Minimum leaving chilled fluid temperature with correct anti-freeze fluid: 15°F (-9.4°C)
- Maximum entering chilled water temperature, operating: 90°F (32.2°C)
- Maximum oil cooler/VFD entering temperature: 90°F (32.2°C)
- Minimum oil cooler/VFD entering temperature: 42°F (5.6°C)



## 4 MECHANICAL INSTALLATION

---

### 4.1 Safety

The machine must be firmly secured to the ground.

It is essential to observe the following instructions:

- The machine must be raised only by the lifting points. Only these points can support the whole weight of the unit.
- Do not allow unauthorised and/or unqualified personnel to access the machine.
- It is forbidden to access the electrical components without having opened the machine's general disconnecting switch and switched off the power supply.
- It is forbidden to access the electrical components without using an insulating platform. Do not access the electrical components if water and/or moisture are present.
- All operations on the refrigerant circuit and on components under pressure must be carried out by qualified personnel only.
- Replacement of a compressor or addition of lubricating oil must be carried out by qualified personnel only- Sharp edges can cause wounds. Avoid direct contact.
- Avoid introducing solid bodies into the water pipes while the machine is connected to the system.
- A mechanical filter must be installed on the water pipe connected to the heat exchanger inlet.
- The machine is supplied with safety valves, that are installed on both the high and the low pressure sides of the refrigerant circuit.



***If the unit mounts suction and discharge valves they need to be secured in open position when the unit is installed, by means of a lead seal or equivalent. This to avoid they are put in closed position. The use of this valve is intended for compressor maintenance.***

---

### 4.2 Positioning and assembly

The unit must be mounted on a level concrete or steel base and must be located to provide service clearance at one end of the unit for possible removal of evaporator tubes and/or condenser tubes. Evaporator and condenser tubes are rolled into the tube sheets to permit replacement if necessary. The length of the vessel should be allowed at one end. Doors or removable wall sections can be utilized for tube clearance.

Minimum clearance at all other points, including the top, is 3 feet (1 meter).

The shipped-loose neoprene vibration pads should be located under the corners of the unit (unless the job specifications state otherwise). They are installed to be flush with the sides and outside edge of the feet. Most DWSC units have six mounting feet although only the outer four are required. Six pads are shipped and the installer can place pads under the middle feet if desired.

Make sure that the floor or structural support is adequate to support the full operating weight of the complete unit.

It is not necessary to bolt the unit to the mounting slab or framework; but should this be desirable, 1 1/8" (28.5 mm) mounting holes are provided in the unit support at the four corners.

### 4.3 System water volume

All chilled water systems need adequate time to recognize a load change, respond to that load change and stabilize, without undesirable short cycling of the compressors or loss of control. In air conditioning systems, the potential for short cycling usually exists when the building load falls below the minimum chiller plant capacity or on close-coupled systems with very small water volumes.

Some of the things the designer should consider when looking at water volume are the minimum cooling load, the minimum chiller plant capacity during the low load period and the desired cycle time for the compressors.

Assuming that there are no sudden load changes and that the chiller plant has reasonable turndown, a rule of thumb of "gallons of water volume equal to two to three times the chilled water gpm flow rate" is often used.

A properly designed storage tank should be added if the system components do not provide sufficient water volume.

### 4.4 Condensation control with evaporative cooling tower

The minimum condenser inlet water temperature should not be less than 20 °C at full water tower flow rate.

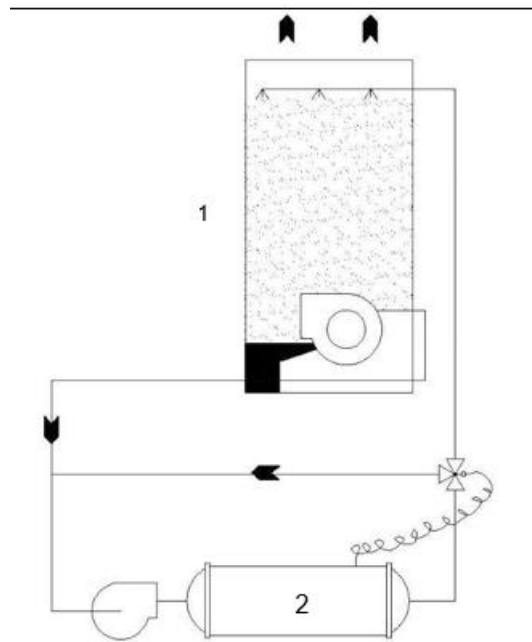
If the water temperature must be lower, even the water flow must be reduced proportionately.

To modulate the water flow to the condenser, install a three-way by-pass valve. The figure shows how the three-way valve is applied to cool the condenser. The three-way valve can be activated by a pressure actuator which guarantees proper condensing pressure in the case where the water temperature entering the condenser is less than 20 °C.

A three-way servo-controlled valve or inverter driven circulation pump could be used instead of a valve with pressure actuator. Both of these devices could be controlled by a 0-10 Vdc analogue signal emitted by the machine electronic controller according to the condenser inlet water temperature.

**Fig. 6 - Condenser control scheme with cooling tower**

1	Cooling tower
2	Condenser



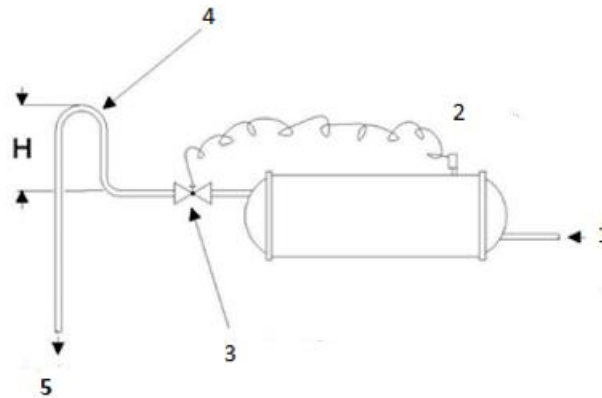
#### 4.5 Condensation control with well water

If ground water is used to cool the condenser, install a normally regulating control valve, direct drive, at condenser outlet. This regulating valve must ensure an adequate condensing pressure in the case where the water temperature entering the condenser is less than 20 °C.

A service valve with pressure outlet is provided on the condenser shell for this purpose.

The valve must modulate its opening according to condensing pressure. When the machine shuts down, the valve will close preventing the condenser from emptying.

**Fig. 7 - Condensation control scheme with well water**



1	From the main condenser pump
2	Service valve
3	Direct acting water regulating valve
4	Configuration required when the regulating valve is not used
5	At Drain

## 4.6 Water piping



**If the charge of the unit is more than 500 kg it is necessary to install gas sensor on water circuit to catch an eventual gas leakage (EN 378).**

### 4.6.1 Water Pumps

Avoid the use of 3600/3000-rpm (two-pole motor) pump motors. It is not uncommon to find that these pumps operate with objectionable noise and vibration.

It is also possible to build up a frequency beat due to the slight difference in the operating rpm of the pump motor and the Daikin centrifugal motor. Daikin encourages the use of 1750/1460 rpm (four-pole) pump motors.

### 4.6.2 Vessel Drains at Start-up

Unit vessels are drained of water in the factory and are shipped with the drain plugs in the heads removed and stored in the control panel or with open ball valves in the drain hole. Be sure to replace plugs or close the valves prior to filling the vessel with fluid.

### 4.6.3 Evaporator and Condenser Water Piping

All evaporators and condensers come standard with Victaulic AWWA C-606 groove nozzles (also suitable for welding), or optional flange connections. The installing contractor must provide matching mechanical connections or transitions of the size and type required.

### 4.6.4 Important Note on Welding

If welding is to be performed on the mechanical or flange connections, remove the solid-state temperature sensor and thermostat bulbs from the wells to prevent damage to those components. Also properly ground the unit or severe damage to the MicroTech unit controller can occur.

Water pressure gauge connection taps and gauges must be provided in the field piping at the inlet and outlet connections of both vessels for measuring the water pressure drops. The pressure drops and flow rates for the various evaporators and condensers are job specific and the original job documentation can be consulted for this information. Refer to the nameplate on the vessel shell for identification.

Be sure that water inlet and outlet connections match certified drawings and stenciled nozzle markings. The condenser is connected with the coolest water entering at the bottom to maximize subcooling.

**Note:** When common piping is used for both heating and cooling modes, care must be taken to provide that water flowing through the evaporator cannot exceed 110°F which can cause the relief valve to discharge refrigerant or damage controls. The piping must be supported to eliminate weight and strain on the fittings and connections. Piping must also be adequately insulated. A cleanable 20-mesh water strainer must be installed in both water inlet lines. Sufficient shutoff valves must be installed to permit draining the water from the evaporator or condenser without draining the complete system.

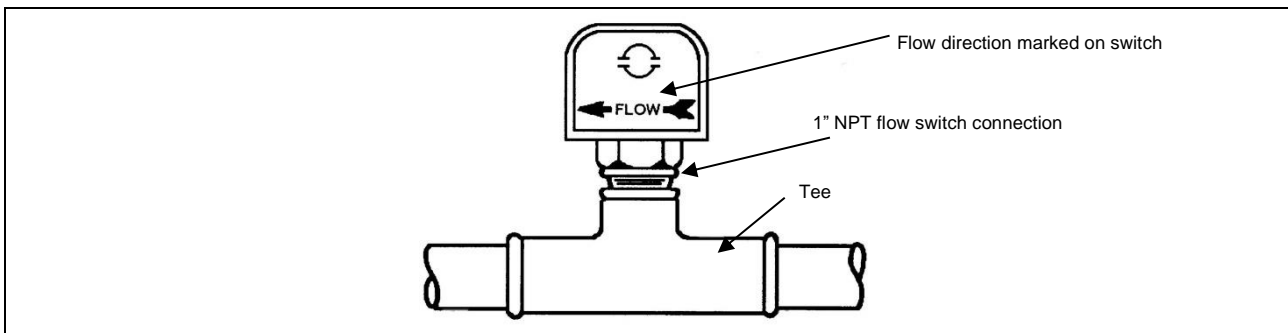
### 4.6.5 Flow Switch

A water flow switch must be installed to signal the presence of adequate water flow to the vessels before the unit can start. They also serve to shut down the unit in the event that water flow is interrupted to guard against evaporator freeze-up or excessive discharge pressure.

Thermal dispersion flow switches and differential pressure switches are available from Daikin as a factory-mounted option. It is mounted in an evaporator and condenser water nozzle and factory wired.

A paddle type flow switch can be supplied by the owner for field mounting and wiring.

**Fig. 8 - Flow switch mounting**



If flow switches, by themselves, are being used, electrical connections in the Unit Electrical Panel must be made following the wiring diagram.

**Table 1 - Flow switch rates**

Pipe Size (NOTE!)		inch	1 1/4	1 1/2	2	2 1/2	3	4	5	6	8
		mm	32 (2)	38 (2)	51	63 (3)	76	102 (4)	127 (4)	153 (4)	204 (5)
Min. Adjst.	Flow	gpm	5.8	7.5	13.7	18.0	27.5	65.0	125.0	190.0	205.0
		Lpm	1.3	1.7	3.1	4.1	6.2	14.8	28.4	43.2	46.6
	No Flow	gpm	3.7	5.0	9.5	12.5	19.0	50.0	101.0	158.0	170.0
		Lpm	0.8	1.1	2.2	2.8	4.3	11.4	22.9	35.9	38.6
Max. Adjst.	Flow	gpm	13.3	19.2	29.0	34.5	53.0	128.0	245.0	375.0	415.0
		Lpm	3.0	4.4	6.6	7.8	12.0	29.1	55.6	85.2	94.3
	No Flow	gpm	12.5	18.0	27.0	32.0	50.0	122.0	235.0	360.0	400.0
		Lpm	2.8	4.1	6.1	7.3	11.4	27.7	53.4	81.8	90.8

**NOTES:**

1. A segmented 3-inch paddle (1, 2, and 3 inches) is furnished mounted, plus a 6-inch paddle loose.
  2. Flow rates for a 2-inch paddle trimmed to fit the pipe.
  3. Flow rates for a 3-inch paddle trimmed to fit the pipe.
  4. Flow rates for a 3-inch paddle.
  5. Flow rates for a 6-inch paddle.
  6. There is no data for pipe sizes above 8-inch. A switch minimum setting should provide protection against no flow and close well before design flow is reached.
- Alternatively, for a higher margin of protection, normally open auxiliary contacts in the pump starters can be wired in series with the flow switches.



**Freeze Notice: Neither the evaporator nor the condenser is self-draining; both must be blown out to help avoid damage from freezing.**

The piping should also include thermometers at the inlet and outlet connections and air vents at the high points. The water heads can be interchanged (end for end) so that the water connections can be made at either end of the unit. If this is done, new head gaskets must be used and control sensors relocated. In cases where the water pump noise can be objectionable, vibration isolation sections are recommended at both the inlet and outlet of the pump. In most cases, it will not be necessary to provide vibration eliminator sections in the condenser inlet and outlet water lines. But they can be required where noise and vibration are critical.

**4.6.6 Cooling Towers**

The condenser water flow rate must be checked to be sure that it conforms to the system design. If tower fan control is not adequate, a tower bypass valve is recommended. Unless the system and chiller unit are specifically for condenser bypass or variable condenser flow is not recommended since low condenser flow rates can cause unstable operation and excessive tube fouling. Tower water treatment is essential for continued efficient and reliable unit operation. If not available in-house, competent water treatment specialists can be contracted.

**4.7 Water treatment**

**Table 2 - Acceptable water quality limits**

DAE Water quality requirements	Shell&tube Flooded	BPHE
Ph (25 °C)	6.8 ÷ 8.4	7.5 – 9.0
Electrical conductivity [ $\mu$ S/cm] (25 °C)	< 800	< 500
Chloride ion [mg Cl- / l]	< 150	< 300
Sulphate ion [mg SO42- / l]	< 100	< 100
Alkalinity [mg CaCO3 / l]	< 100	< 200
Total Hardness [mg CaCO3 / l]	< 200	75 ÷ 150
Iron [mg Fe / l]	< 1	< 0.2
Ammonium ion [mg NH4+ / l]	< 1	< 0.5
Silica [mg SiO2 / l]	< 50	NO
Chlorine molecular (mg Cl2/l)	< 5	< 0.5

4.8 Field Insulation Guide

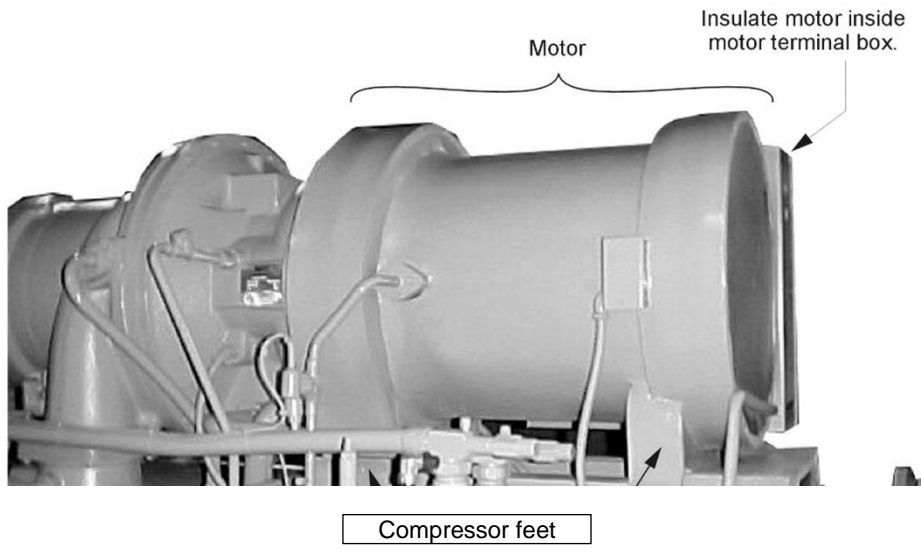
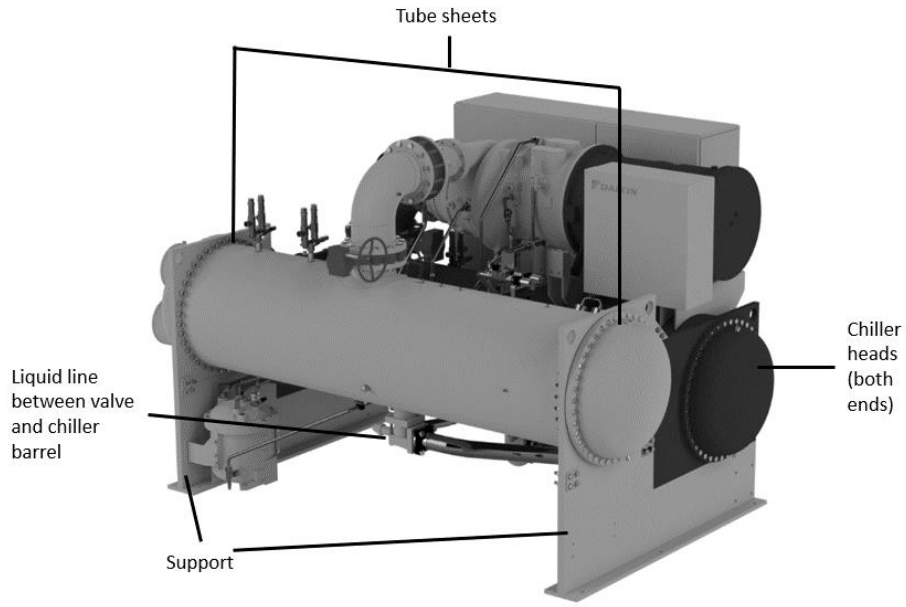
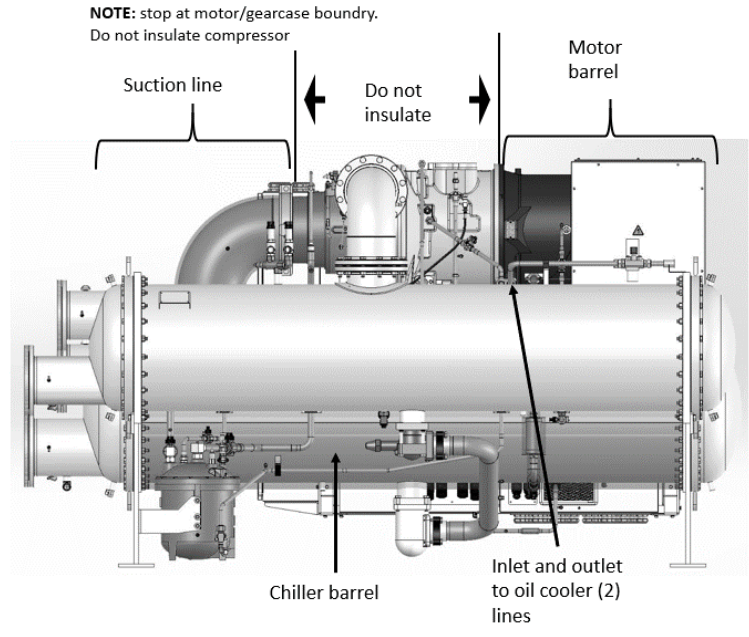


Note: Starter mounting brackets if supplied.

Motor Drain Line Motor to Chiller



Expansion Valve - Insulate crosshatch area & up to the chiller insulation.



## 4.9 PHYSICAL DATA AND WEIGHTS

### 4.9.1 Evaporator

The standard insulation of cold surfaces includes the evaporator and non-connection water head, suction piping, compressor inlet, motor housing, and motor coolant outlet line.

It is 20 mm (3/4") thick ABS/PVC flexible foam with a skin. The K factor is 0.28 at 75°F. Sheet insulation is fitted and cemented in place forming a vapor barrier.

Refrigerant-side design pressure is 13.7 bar on DWSC. Water-side is 10 bar on all standard units.

In the event insulation is to be field-installed, none of the cold surfaces identified above will be factory insulated. Required field insulation is shown beginning on page 21. Approximate total square footage of insulation surface required for individual packaged chillers is tabulated by evaporator code and can be found below.

**Table 3 - Evaporator Data**

Evaporator code	Refrigerant charge (kg)	Water Capacity (l)	Insulation Area (m <sup>2</sup> )	Vessel dry Weight (kg)	Add for MWB Weight (kg)	MWB Cover only Weight (kg)	Number of Relief Valves 1" NPT
E2410	220	248	9.0	1530	233	106	1
E2610	260	318	10.0	1924	247	125	1
E3210	390	579	12.0	2122	354	202	1
E3810	560	888	14.5	3100	572	344	1
E4410	760	1275	17.0	3849	771	498	2

1. Refrigerant charge is approximate since the actual charge will depend on other variables. Actual charge will be shown on the unit nameplate.
2. Water capacity is based on standard tube configuration and standard dished heads.
3. The evaporator charge includes the maximum condenser charge available with that evaporator and is therefore the maximum charge for a total unit with the evaporator. Actual charge for a specific selection can vary with tube count and can be obtained from the Daikin Selection Program.

### 4.9.2 Condenser

With positive pressure systems, the pressure variance with temperature is always predictable, and the vessel design and relief protection are based upon pure refrigerant characteristics. R-134a, R-513a and R-1234ze require PED/ASME vessel design, inspection and testing and use spring-loaded pressure relief valves. When an over pressure condition occurs, spring-loaded relief valves purge only that refrigerant required to reduce system pressure to their set pressure, and then close.

Refrigerant side design pressure is 13,7 bar on DWSC units. Water side design is 10 bar on all.

### 4.9.3 Pumpdown

To facilitate compressor service, all Daikin centrifugal chillers are designed to permit pumpdown and isolation of the entire refrigerant charge in the unit's condenser. Dual compressor units and single compressor units equipped with the optional suction shutoff valve can also be pumped down into the evaporator.

**Table 4 - Condenser Data**

Condenser Code	Pumpdown Capacity (m <sup>3</sup> )	Water Capacity (l)	Insulation Area (m <sup>2</sup> )	Vessel dry Weight (kg)	Add for MWB Weight (kg)	MWB Cover only Weight (kg)	Number of Relief Valves 1" NPT
C2210	0.5	346	8.2	1770	206	94	1
C2410	0.5	438	8.9	2193	233	106	1
C2810	0.7	616	10.4	2314	270	143	1
C3010	0.8	717	11.0	2499	329	191	1
C3210	0.9	852	11.8	2706	354	202	1
C3810	1.2	1257	14.2	3952	571	344	1
C4010	1.3	1418	14.8	4224	592	377	2

1. Condenser pumpdown capacity based on maximum tubes number for the maximum charge at 36 °C.
2. Water capacity based on standard configuration and standard heads and can be less with lower tube counts.

3. See Relief Valves section for additional information.



#### 4.9.4 Compressor

**Table 5 - Compressor Weights**

Compressor Size	79	87	100	113	126
Weight lb. (kg)	3200 (1440)	3200 (1440)	6000 (2700)	6000 (2700)	6000 (2700)

#### 4.10 Oil Coolers

Daikin centrifugal chillers, sizes 079 through 126, have a factory-mounted, water-cooled oil cooler, temperature-controlled water regulating valve and solenoid valve per compressor.

DWSC single compressor cooling water connections are located near the compressor and are shown on the specific unit certified drawings.

Field water piping to the inlet and outlet connections must be installed according to good piping practices and include stop valves to isolate the cooler for servicing. A cleanable filter (40 mesh maximum), and drain valve or plug must also be field-installed. The water supply for the oil cooler should be from the chilled water circuit or from a clean, independent source, no warmer than 80°F (27°C), such as city water. When using chilled water, it is important that the water pressure drop across the evaporator is greater than the pressure drop across the oil cooler or insufficient oil cooler flow will result. If the pressure drop across the evaporator is less than the oil cooler, the oil cooler must be piped across the chilled water pump, provided that its pressure drop is sufficient. The water flow through the oil cooler will be adjusted by the unit's regulating valve so that the temperature of oil supplied to the compressor bearings (leaving the oil cooler) is between 95°F and 105°F (35°C and 40°C).

**Table 6 - DWSC, Oil cooler Data**

<b>DWSC/DHSC 079 - 087</b>		<b>Cold Side Water</b>		
Flow, gpm	11.9	2.9	2.0	1.54
Inlet Temperature, °F	80.0	65.0	55.0	45.0
Outlet Temperature, °F	87.3	94.5	98.4	101.5
Pressure Drop, ft.	9.9	0.6	0.3	0.2
<b>DWSC/DHSC 100 - 126</b>		<b>Cold Side Water</b>		
Flow, gpm	21.9	5.1	3.5	2.7
Inlet Temperature, °F	80.0	65.0	55.0	45.0
Outlet Temperature, °F	87.0	95.0	99.1	102.4
Pressure Drop, ft.	8.7	0.5	0.2	0.1

DWDC dual compressor units will have twice the cooling water flow rate of the comparable DWSC chiller and the pressure drop will be the same.

Pressure drops include valves on the unit.

Compressors using chilled water for oil cooling will often start with warm "chilled water" in the system until the chilled water loop temperature is pulled down. Data given above includes that condition. As can be seen, with cooling water in the 45°F to 65°F (7 °C to 18 °C) range, considerably less water will be used, and the pressure drop will be greatly reduced.

When supplied with city water, the oil piping must discharge through a trap into an open drain to prevent draining the cooler by siphoning. The city water can also be used for cooling tower makeup by discharging it into the tower sump from a point above the highest possible water level.

**NOTE:** Particular attention must be paid to chillers with variable chilled water flow through the evaporator. The pressure drop available at low flow rates can very well be insufficient to supply the oil cooler with enough water. In this case an auxiliary booster pump can be used or city water employed.

---

***Particular attention must be paid to chillers with variable chilled water flow through the evaporator.***

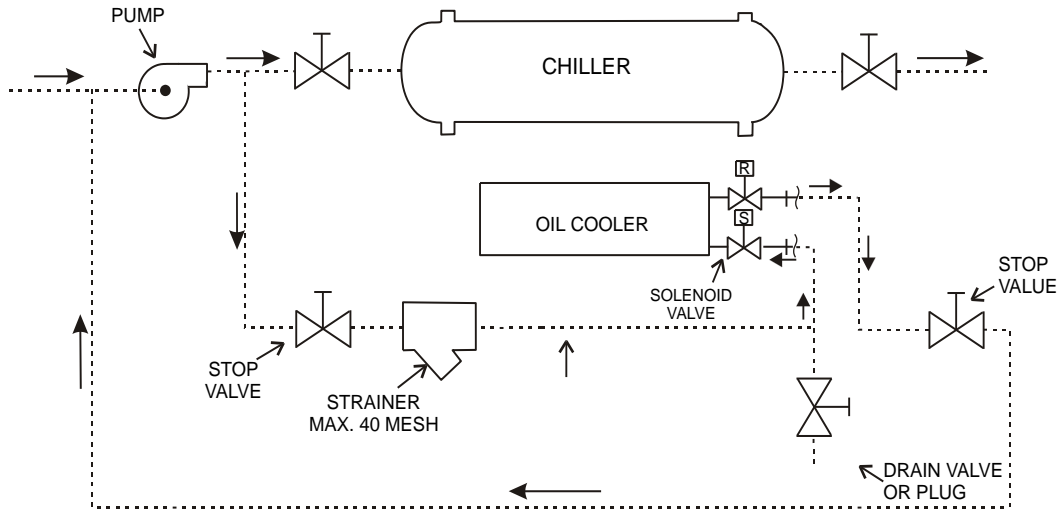


***The pressure drop available at low flow rates can very well be insufficient to supply the oil cooler with enough water.***

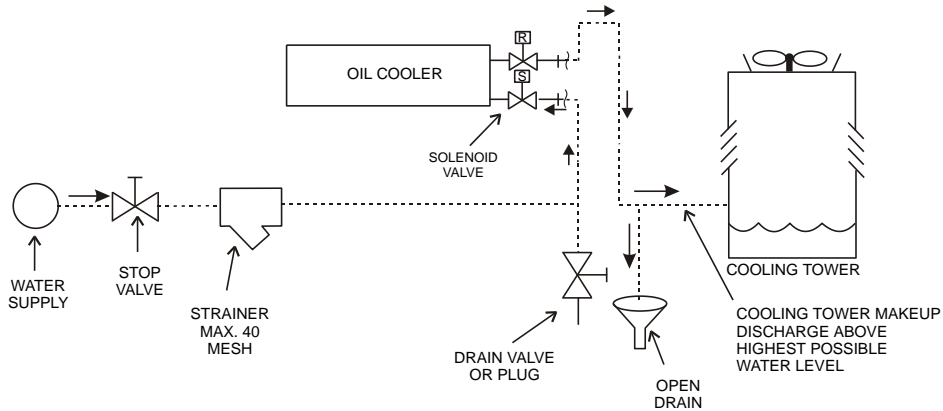
***In this case an auxiliary booster pump can be used or city water employed.***

---

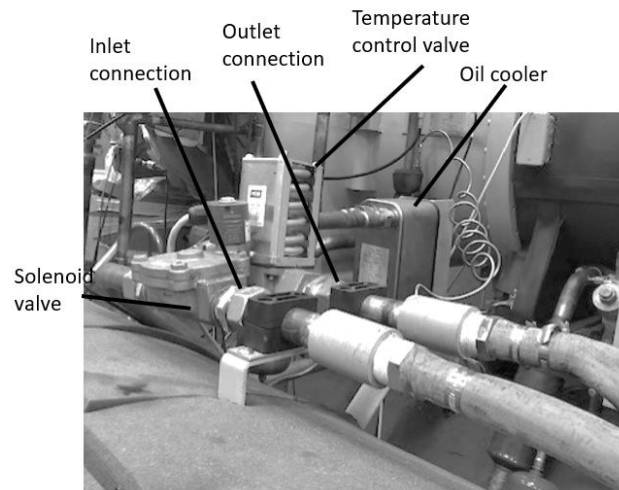
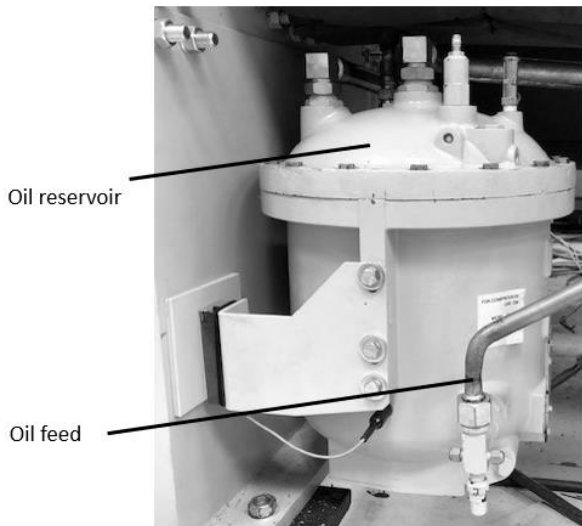
**Fig. 9 - Oil Cooler Piping Across Chilled Water Pump**



**Fig. 10 - Oil Cooler Piping With City Water**



**Fig. 11 - DWSC, Oil cooling connections**



**Table 7 - Cooling Water connection sizes**

<b>Model</b>	DWSC 079-126
<b>Conn Size (in.)</b>	1 in.

#### 4.11 Oil Heater

The oil sump is equipped with an immersion heater that is installed in a tube so that it can be removed without disturbing the oil.

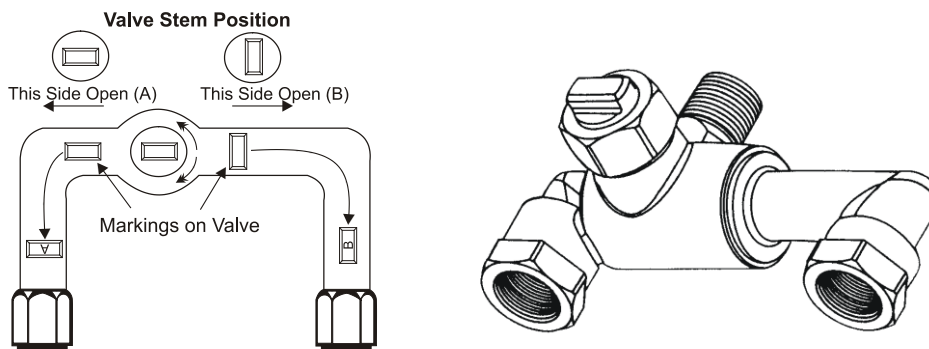
#### 4.12 Relief Valves

As a safety precaution and to meet code requirements, each chiller is equipped with pressure relief valves located on the condenser, evaporator, and oil sump vessel for the purpose of relieving excessive refrigerant pressure (caused by equipment malfunction, fire, etc.) to the atmosphere. Most codes require that relief valves be vented to the outside of a building, and this is a desirable practice for all installations. Relief piping connections to the relief valves must have flexible connectors.

**Note:** Remove plastic shipping plugs (if installed) from the inside of the valves prior to making pipe connections. Whenever vent piping is installed, the lines must be run in accordance with local code requirements; where local codes do not apply, the latest issue of ANSI/ASHRAE Standard 15 code or EN 13136 recommendations must be followed.

Condensers have two relief valves as a set with a three-way valve separating the two valves (large condensers will have two such sets). One valve remains active at all times and the second valve acts as a standby.

Fig. 12 - Condenser 3-Way Valve



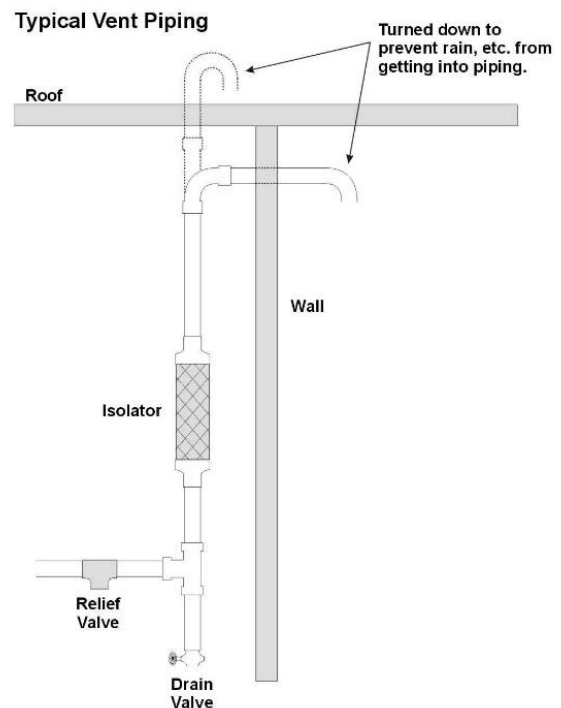
##### 4.12.1 Refrigerant Vent Piping

Twin relief valves mounted on a transfer valve are used on the condenser so that one relief valve can be shut off and removed, leaving the other in operation.

Only one of the two is in operation at any time. Where four valves are shown in the table, they consist of two valves, each mounted on two transfer valves.

Only two relief valves of the four are active at any time.

Vent piping is sized for only one valve of the set since only one can be in operation at a time.



## 5 ELECTRICAL INSTALLATION

---

### 5.1 General specifications

Refer to the specific wiring diagram for the unit you have bought. Should the wiring diagram not be on the unit or should it have been lost, please contact your manufacturer representative, who will send you a copy.

In case of discrepancy between wiring diagram and electrical panel/cables, please contact the manufacturer representative.



**All electrical connections to the unit must be carried out in compliance with laws and regulations in force.**

**All installation, management and maintenance activities must be carried out by qualified personnel. There is a risk of electric shock.**

---

The units of the series can be provided with non-linear high power electrical components (inverters) which introduce higher harmonics, can cause considerable leakage to earth, (higher than 300 mA).

The electricity supply system protection must take the above values into account.



**Before any installation and connection works, the unit must be switched off and secured. Since this unit includes inverters, the intermediate circuit of the capacitors remains charged with high voltage for a short period of time after being switched off.**

**Do not operate to the unit before 20 minutes after the unit has been switched off.**

---

Electrical equipment is capable of operating correctly in the intended ambient air temperature. For very hot environments and for cold environments, additional measures are recommended (contact the manufacturer representative).

The electrical equipment is capable of operating correctly when the relative humidity does not exceed 50 % at a maximum temperature of +42 °C. Higher relative humidities are permitted at lower temperatures (for example 90% at 20 °C).

Harmful effects of occasional condensation shall be avoided by design of the equipment or, where necessary, by additional measures (contact the manufacturer representative).

This product complies with EMC standards for industrial environments. Therefore it is not intended for use in residential areas, e.g. installations where the product is connected to a low voltage public distribution system. Should this product need to be connected to a low voltage public distribution system, specific additional measures will have to be taken to avoid interference with other sensitive equipment.

### 5.2 Electrical supply

The electrical equipment can operate correctly with the conditions specified below:

<b>Voltage</b>	Steady state voltage: 0,9 to 1,1 of nominal voltage.
<b>Frequency</b>	0,99 to 1,01 of nominal frequency continuously 0,98 to 1,02 short time
<b>Armonics</b>	Harmonic distortion not exceeding 10 % of the total r.m.s. voltage between live conductors for the sum of the 2nd through to the 5 <sup>th</sup> harmonic. An additional 2 % of the total r.m.s. voltage between live conductors for the sum of the 6th through to the 30th harmonic is permissible.
<b>Voltage unbalance</b>	Neither the voltage of the negative sequence component nor the voltage of the zero sequence component in three-phase supplies exceeding 3 % of the positive sequence component.
<b>Voltage interruption</b>	Supply interrupted or at zero voltage for not more than 3 ms at any random time in the supply cycle with more than 1 s between successive interruptions.
<b>Voltage dips</b>	Voltage dips not exceeding 20% of the peak voltage of the supply for more than one cycle with more than 1 s between successive dips.

### 5.3 Power wiring

Power wiring to compressors must be in proper phase sequence. Motor rotation is set up for clockwise rotation facing the lead end with phase sequence of 1-2-3. Care must be taken that the proper phase sequence is carried through the starter to compressor. See wiring diagram.

The Daikin start-up technician will determine the phase sequence. If the unit is supplied with a Daikin VFD composed by two parallel inverters (starters V6, V7, V8, V9, VA, VB, L6, L7, L8, L9, LA and LB), the compressor is equipped with a dual three-phase induction motor.

## 5.4 Control power wiring

Under no circumstances should a compressor be brought up to speed unless proper sequence and rotation have been established. Serious damage can result if the compressor starts in the wrong direction. Such damage is not covered by product warranty.

It is the installing contractor's responsibility to insulate the compressor motor terminals when the unit voltage is 600 volts or greater. This is to be done after the Daikin start-up technician has checked for proper phase sequence and motor rotation.

The control circuit on the Daikin centrifugal packaged chiller is designed for 400 volts. Control power can be supplied from three different sources:

1. If the unit is supplied with a factory-mounted starter or VFD, the control circuit power supply is factory-wired from a transformer located in the starter or VFD.
2. A freestanding starter or VFD furnished by Daikin, or by the customer to Daikin specifications, will have a control transformer in it and requires field wiring to terminals in the compressor terminal box.
3. Power can be supplied from a separate circuit. The control circuit disconnect switch must be tagged to prevent current interruption. **Other than for service work, the switch is to remain on at all times in order to keep oil heaters operative and prevent refrigerant from diluting in oil.**



***If a separate control power source is used, the following must be done to avoid severe personal injury or death from electrical shock:***

1. ***Place a notice on the unit that multiple power sources are connected to the unit.***
2. ***Place a notice on the main and control power disconnects that another source of power to the unit exists.***

## 5.5 Flow Switches

Water flow interlock terminals are provided on the Unit Control Panel terminal strip for field-mounted switches. The purpose of the water flow interlocks is to prevent compressor operation until such time as both the evaporator water and condenser water pumps are running and flow is established. A flow switch must be installed before the unit can be started.

## 5.6 Control Panel Switches

Three mode switches are located in the central part of the main Unit Control Panel. They have the following function:

- **Q0 - UNIT** executes an immediate shutdown of the chiller without the normal shutdown cycle and provides a post-lube period.
- **Q1 - COMPRESSOR** one switch for each compressor on a unit, shuts down the compressor through the normal shutdown cycle of unloading and provides a post-lube period.
- **Q8 – COOLING/HEATING** defines the operating mode of the unit.

## 5.7 Cable requirements

The cables connected to the circuit breaker must respect the insulation distance in the air and the surface isolation distance between the active conductors and the earth, according to IEC 61439-1 table 1 and 2, and to the local national laws.

The cables connected to the main switch must be tightened using a pair of keys and respecting the unified clamping values, relative to the quality of the screws of the washers and nuts used.

**Connect the earth conductor (yellow / green) to the PE ground terminal.**

The equipotential protection conductor (earth conductor) must have a section according to table 1 of EN 60204-1 Point 5.2, shown below.

**Table 8 - Table 1 of EN60204-1 Point 5.2**

<b>Section of the copper phase conductors feeding the equipment</b> S [mm <sup>2</sup> ]	<b>Minimum cross-section of the external copper protection conductor</b> Sp [mm <sup>2</sup> ]
S ≤ 16	S
16 < S ≤ 35	16
S > 35	S/2

In any case, the equipotential protection conductor (earth conductor) must have a cross section of at least 10 mm<sup>2</sup>, in accordance with point 8.2.8 of the same standard.

## 5.8 Phase unbalance

In a three-phase system, the excessive imbalance between the phases is the cause of the engine overheating. The maximum permitted voltage unbalance is 3%, calculated as follows:

$$\text{Unbalance \%} = \frac{(V_x - V_m) * 100}{V_m}$$

where:

$V_x$  = phase with greater unbalance

$V_m$  = average of the tensions

Example: the three phases measure 383, 386 and 392 V respectively. The average is:

$$\frac{383 + 386 + 392}{3} = 387 \text{ V}$$

The unbalance percentage is:

$$\frac{(392 - 387) * 100}{387} = \mathbf{1.29 \%}$$

less than the maximum allowed (3%).

## 6 PRESTART SYSTEM CHECKLIST

<b>Cooled water circuit</b>	<b>Yes</b>	<b>No</b>	<b>N/D</b>
Piping complete	<input type="checkbox"/>	<input type="checkbox"/>	<input type="checkbox"/>
Clean water circuit, full and air drained	<input type="checkbox"/>	<input type="checkbox"/>	<input type="checkbox"/>
Pumps installed and operating (rotation checked)	<input type="checkbox"/>	<input type="checkbox"/>	<input type="checkbox"/>
Filters installed and clean	<input type="checkbox"/>	<input type="checkbox"/>	<input type="checkbox"/>
Control operations (three-way valve, bypass valve, etc.)	<input type="checkbox"/>	<input type="checkbox"/>	<input type="checkbox"/>
Flow switch installed	<input type="checkbox"/>	<input type="checkbox"/>	<input type="checkbox"/>
Water circuit operating and flows balanced at required conditions	<input type="checkbox"/>	<input type="checkbox"/>	<input type="checkbox"/>
<b>Condenser water circuit</b>	<b>Yes</b>	<b>No</b>	<b>N/D</b>
Clean water circuit, full and air drained	<input type="checkbox"/>	<input type="checkbox"/>	<input type="checkbox"/>
Pumps installed and operating (rotation checked)	<input type="checkbox"/>	<input type="checkbox"/>	<input type="checkbox"/>
Filters installed and clean	<input type="checkbox"/>	<input type="checkbox"/>	<input type="checkbox"/>
Controls operable (three-way valve, bypass valve, etc.)	<input type="checkbox"/>	<input type="checkbox"/>	<input type="checkbox"/>
Water circuit operating and flows balanced at required conditions	<input type="checkbox"/>	<input type="checkbox"/>	<input type="checkbox"/>
<b>Electrical network</b>	<b>Yes</b>	<b>No</b>	<b>N/D</b>
Power leads connected to starter; load leads run to compressor ready for connection when service engineer is on hand for start-up	<input type="checkbox"/>	<input type="checkbox"/>	<input type="checkbox"/>
All interlock wiring complete between control panel and complies with specifications	<input type="checkbox"/>	<input type="checkbox"/>	<input type="checkbox"/>
Starter complies with specifications	<input type="checkbox"/>	<input type="checkbox"/>	<input type="checkbox"/>
Pump starters and interlock wired	<input type="checkbox"/>	<input type="checkbox"/>	<input type="checkbox"/>
Cooling tower fans and controls wired	<input type="checkbox"/>	<input type="checkbox"/>	<input type="checkbox"/>
Electrical connections compliant with local electrical standards	<input type="checkbox"/>	<input type="checkbox"/>	<input type="checkbox"/>
<b>Miscellaneous</b>			
Oil cooler water piping complete (units with water cooled oil coolers only)	<input type="checkbox"/>	<input type="checkbox"/>	<input type="checkbox"/>
Relief valve piping complete	<input type="checkbox"/>	<input type="checkbox"/>	<input type="checkbox"/>
Thermometer wells, thermometers, gauges, control wells, controls, etc., installed	<input type="checkbox"/>	<input type="checkbox"/>	<input type="checkbox"/>
Minimum system load of 80% of machine capacity available for testing and adjusting controls	<input type="checkbox"/>	<input type="checkbox"/>	<input type="checkbox"/>

**This checklist must be completed and sent to the local Daikin service location two weeks prior to start-up.**

## 7 OPERATION

### 7.1 Operator's responsibilities

It is important that the operator becomes familiar with the equipment before operating the machine. In addition to reading this manual, the operator should study the operation manual and the wiring diagram supplied with the unit to understand commissioning, operation and the shutdown sequence as well as the shutdown mode and safeties.

During initial machine start-up, the Daikin technician is available to answer any questions and instruct on proper operating procedures.

The operator should keep an operating data log for each specific machine. Furthermore, an additional maintenance log should be kept for periodic maintenance and service.

This Daikin unit represents a substantial investment and deserves the attention and care to keep this equipment in good working order. If the operator observes abnormal or unusual operating conditions, calling Daikin technical service is recommended.

In any case, it is essential to follow the instructions below during operation and maintenance:

- Do not allow unauthorized and/or unskilled personnel to access the unit.
- It is forbidden to access the electrical components without having opened the unit main switch and switched off the power supply.
- It is forbidden to access the electrical components without using an insulating platform. Do not access electrical components if water and/or moisture are present.
- Ensure that all operations on the refrigerant circuit and on components under pressure are exclusively carried out by qualified personnel.
- Compressors should only be replaced by qualified personnel.
- Sharp edges can cause injuries. Avoid direct contact.
- Do not introduce solid objects into the water pipes while the unit is connected to the system.
- A mechanical filter must be fitted to the water pipe connected to the heat exchanger inlet.
- It is absolutely forbidden to remove any protection system covering moving parts.

In case of sudden stop of the unit, follow the instructions on the Control Panel Operating Manual which is part of the on-board documentation delivered to the end user.

It is strongly recommended to perform installation and maintenance with other people.

### 7.2 Standby Power

It is essential that any centrifugal chiller connected to standby power come to a complete stop on grid power and then be restarted with the standby power. Attempting to switch from regular grid line power to auxiliary power while the compressor is running can result in extreme transient torque that will severely damage the compressor.

### 7.3 Lubrication System

The lubrication system provides lubrication and heat removal for compressor bearings and internal parts. In addition, the system provides lubricant under pressure to hydraulically operate the unloading piston for positioning the inlet guide vanes for capacity control.

Only the recommended lubricant, as shown in Table 9, can be used for proper operation of the hydraulic system and bearing lubrication system. Each unit is factory-charged with the correct amount of the recommended lubricant. Under normal operation, no additional lubricant is needed. Lubricant must be visible in the sump sight glass at all times.

The compressor sizes, CE079, through CE126, utilize a separate lubricant pump located in the sump. The sump includes the pump, motor, heater and lubricant/vapor separator system. The lubricant is pumped through the external oil cooler and then to the oil filter located inside the compressor housing. DWSC 079-126 units all utilize a water-cooled oil cooler for the compressor.

The oil coolers maintain the proper oil temperature under normal operating conditions. The coolant flow control valve maintains 95°F to 105°F (35 °C to 41 °C). Lubrication protection for coast down in the event of a power failure is accomplished by a spring-loaded piston in models CE079 through 100. When the oil pump is started, the piston is forced back against the spring by the oil pressure, compressing the spring, and filling the piston cavity with oil. When the pump stops, the spring pressure on the piston forces the oil back out to the bearings.

In model CE126 the compressor coast down lubrication is supplied from a gravity feed oil reservoir.

**Table 9 - Approved Polyolester oils for R134a units**

Compressor Models	CE079 - 126
Lubricant Designation	Mobil Artic EAL 46; ICI Emkarate RL32H(2)
Daikin Part Number	
55 Gal. Drum	735030432, Rev 47
5 Gal. Drum	735030433, Rev 47
1 Gal. Can	735030435, Rev 47
Compressor Oil Label	070200106, Rev OB



**NOTES:**

1. Approved oil from two suppliers can be mixed, although they have slightly different viscosity.
2. Lubricant from either supplier can be furnished when ordering by Daikin part number.

**7.4 Hot Gas Bypass**

All units can be equipped with an optional hot gas bypass system that feeds discharge gas directly into the evaporator when the system load falls below the minimum compressor capacity.

Light load conditions are estimated on IGV position and motor speed measurement. When the load drops to the setpoint, the hot gas bypass solenoid valve is energized, making hot gas bypass available for metering by the hot gas regulating valve. This hot gas provides a stable refrigerant flow and keeps the chiller from short cycling under light load conditions. It also reduces surge potential on heat recovery units.

**7.5 Condenser Water Temperature**

When the ambient wet bulb temperature is lower than design, the entering condenser water temperature can be allowed to fall, improving chiller performance.

Daikin chillers will *start* with entering condenser water temperature as low as 55°F (12.8°C) providing the chilled water temperature is below the condenser water temperature.

The minimum *operating* entering condenser water temperature is a function of the leaving chilled water temperature and load. Even with tower fan control, some form of water flow control such as tower bypass must be used.

## 8 MAINTENANCE

### 8.1 Pressure/Temperature Chart

HFC-R134a Temperature Pressure Chart							
°F	PSIG	°F	PSIG	°F	PSIG	°F	PSIG
6	9.7	46	41.1	86	97.0	126	187.3
8	10.8	48	43.2	88	100.6	128	192.9
10	12.0	50	45.4	90	104.3	130	198.7
12	13.2	52	47.7	92	108.1	132	204.5
14	14.4	54	50.0	94	112.0	134	210.5
16	15.7	56	52.4	96	115.9	136	216.6
18	17.1	58	54.9	98	120.0	138	222.8
20	18.4	60	57.4	100	124.1	140	229.2
22	19.9	62	60.0	102	128.4	142	235.6
24	21.3	64	62.7	104	132.7	144	242.2
26	22.9	66	65.4	106	137.2	146	249.0
28	24.5	68	68.2	108	141.7	148	255.8
30	26.1	70	71.1	110	146.3	150	262.8
32	27.8	72	74.0	112	151.1	152	270.0
34	29.5	74	77.1	114	155.9	154	277.3
36	31.3	76	80.2	116	160.9	156	284.7
38	33.1	78	83.4	118	166.0	158	292.2
40	35.0	80	86.7	120	171.1	160	299.9
42	37.0	82	90.0	122	176.4	162	307.8
44	39.0	84	93.5	124	181.8	164	315.8

HFC/HFO-R513A Temperature Pressure Chart							
°F	PSIG	°F	PSIG	°F	PSIG	°F	PSIG
6	13.0	46	46.5	86	104.4	126	196.0
8	14.2	48	48.7	88	108.1	128	201.7
10	15.5	50	51.0	90	111.9	130	207.5
12	16.8	52	53.4	92	115.7	132	213.4
14	18.1	54	55.8	94	119.7	134	219.4
16	19.5	56	58.3	96	123.7	136	225.5
18	21.0	58	60.9	98	127.9	138	231.7
20	22.4	60	63.5	100	132.1	140	238.1
22	24.0	62	66.2	102	136.4	142	244.6
24	25.6	64	69.0	104	140.8	144	251.2
26	27.2	66	71.8	106	145.4	146	258.0
28	28.9	68	74.8	108	150.0	148	264.8
30	30.6	70	77.7	110	154.7	150	271.8
32	32.4	72	80.8	112	159.5	152	279.0
34	34.3	74	83.9	114	164.4	154	286.3
36	36.2	76	87.1	116	169.4	156	293.7
38	38.1	78	90.4	118	174.5	158	301.2
40	40.1	80	93.8	120	179.7	160	308.9
42	42.2	82	97.3	122	185.1	162	316.7
44	44.3	84	100.8	124	190.5	164	324.7

HFC-R1234ze Temperature Pressure Chart							
°F	PSIG	°F	PSIG	°F	PSIG	°F	PSIG
6	3.1	46	26.8	86	69.2	126	138.3
8	4.0	48	28.4	88	71.9	128	142.6
10	4.8	50	30.0	90	74.8	130	147.0
12	5.8	52	31.7	92	77.6	132	151.5
14	6.7	54	33.5	94	80.6	134	156.1
16	7.7	56	35.3	96	83.6	136	160.8
18	8.7	58	37.2	98	86.7	138	165.6
20	9.7	60	39.1	100	89.9	140	170.5
22	10.8	62	41.1	102	93.1	142	175.4
24	11.9	64	43.1	104	96.5	144	180.5
26	13.0	66	45.2	106	99.9	146	185.7
28	14.2	68	47.3	108	103.3	148	191.0
30	15.4	70	49.5	110	106.9	150	196.3
32	16.7	72	51.7	112	110.5	152	201.8
34	18.0	74	54.0	114	114.2	154	207.4
36	19.4	76	56.4	116	118.0	156	213.1
38	20.8	78	58.8	118	121.9	158	219.0
40	22.2	80	61.3	120	125.9	160	224.9
42	23.7	82	63.9	122	129.9	162	230.9
44	25.2	84	66.5	124	134.1	164	237.1

## 8.2 Routine Maintenance

### 8.2.1 Lubrication



***Improper servicing of the lubrication system, including the addition of excessive or incorrect oil, substitute quality oil filter, or any mishandling can damage the equipment. Only authorized and trained service personnel should attempt this service. For qualified assistance, contact your local Daikin service location.***

After the system is once placed into operation, no other additional oil is required except in the event that repair work becomes necessary to the oil pump, or unless a large amount of oil is lost from the system due to a leak.

If oil must be added with the system under pressure, use a hand pump with its discharge line connected to the backseat port of the valve in the lubricant drain from the compressor to the sump. The POE oils used with R-134a, R-513A and R-1234ze are hygroscopic and care must be exercised to avoid exposure to moisture (air).

The condition of compressor oil can be an indication of the general condition of the refrigerant circuit and compressor wear. An annual oil check by a qualified laboratory is essential for maintaining a high level of maintenance. It is useful to have an oil analysis at initial startup to provide a benchmark from which to compare future tests. The local Daikin service office can recommend suitable facilities for performing these tests.

#### 8.2.1.1 Interpreting Oil Analysis Data

Oil wear metals analysis has long been recognized as a useful tool for indicating the internal condition of rotating machinery and continues to be a preferred method for Daikin centrifugal chillers. Daikin Service or a number of laboratories specializing in oil testing can do the test. To accurately estimate the internal condition it is essential to properly interpret the oil wear test results.

Numerous test results from various testing laboratories have recommended action that has prompted unnecessary concern by customers. Polyolester oils are excellent solvents and can readily dissolve trace elements and contaminants. Most of these elements and contaminants eventually end up in the oil. Also, the polyolester oils used in R-134a, R-513A and R-1234ze chillers are more hygroscopic than mineral oils and can contain much more water in solution. For this reason, it is imperative that extra care be used when handling polyolester oils to minimize their exposure to ambient air. Extra care must also be used when sampling to ensure that sample containers are clean, moisture-free leak proof and non-permeable. Daikin has done extensive testing in conjunction with refrigerant and lubricating oil manufacturers and has established guidelines to determine action levels and the type of action required.

In general Daikin does not recommend changing lubricating oils and filters on a periodic basis. The need to change lubricating oil and filters should be based on a careful consideration of oil analysis, vibration analysis and knowledge of the

operating history of the equipment. A single oil sample is not sufficient to estimate the condition of the chiller. Oil analysis is only useful if employed to establish wear trends over time. Changing lubricating oil and filter prior to when its needed will reduce the effectiveness of oil analysis as a tool in determining machinery condition.

The following metallic elements or contaminants and their possible sources will typically be identified in an oil wear analysis.

#### **Aluminum**

Typical sources of aluminum are bearings, impellers, seals or casting material. An increase in aluminum content in the lubricating oil may be an indication of bearing, impeller or other wear. A corresponding increase in other wear metals may also accompany an increase in aluminum content.

#### **Copper**

The source of copper can be the evaporator or condenser tubes, copper tubing used in the lubrication and motor cooling systems or residual copper from the manufacturing process. The presence of copper may be accompanied by a high TAN (total acid number) and high moisture content. High copper contents may also result from residual mineral oil in machines which have been converted to R-134a, R-513A and R-1234ze. Some mineral oils contained wear inhibitors which react with copper and result in high copper content in lubricating oil.

#### **Iron**

Iron in the lubricating oil can originate from compressor castings, oil pump components, shells, tube sheets, tube supports, shaft material and rolling element bearings. High iron content may also result from residual mineral oil in machines which have been converted to R-134a, R-513A and R-1234ze. Some mineral oils contain wear inhibitors which react with iron and can result in a high iron content in the lubricating oil.

#### **Tin**

The source of tin may be from bearings.

#### **Zinc**

There is no zinc used in the bearings on Daikin chillers. The source, if any may be from additives in some mineral oils.

#### **Lead**

The source of lead in Daikin centrifugal chillers is the thread sealant compounds used during chiller assembly. The presence of lead in the lubricating oil in Daikin chillers does not indicate bearing wear.

#### **Silicon**

Silicon can originate from residual particles of silicon left from the manufacturing process, filter drier material, dirt or anti-foam additives from residual mineral oil which may be present in machines that have been converted to R-134a, R-513A and R-1234ze.

#### **Moisture**

Moisture in the form of dissolved water can be present in lubricating oil to varying degrees. Some polyolester oils may contain up to 50 parts per million (ppm) of water from new unopened containers. Other sources of water may be the refrigerant (new refrigerant may contain up to 10 ppm water), leaking evaporator condenser tubes or oil coolers, or moisture introduced by the addition of either contaminated oil or refrigerant or improperly handled oil.

Liquid R-134a has the ability to retain up to 1400 ppm of water in solution at 100 degrees F. With 225 ppm of water dissolved in liquid R-134a, free water would not be released until the liquid temperature reached -22 degrees F. Liquid R-134a can hold approximately 470 ppm at 15 degrees F (an evaporator temperature which could be encountered in ice applications). Since free water is what causes acid production, moisture levels should not be of a concern until they approach the free water release point.

A better indicator of a condition which should be of concern is the TAN (Total Acid Number). A TAN below 0.09 requires no immediate action. TANs above 0.09 require certain actions. In the absence of a high TAN reading and a regular loss of refrigerant oil (which may indicate a heat transfer surface leak) a high moisture content in an oil wear analysis is probably due to handling or contamination of the oil sample. It should be noted that air (and moisture) can penetrate plastic containers. Metal or glass containers with gasket in the top will slow moisture entry.

In conclusion, a single element of an oil analysis should not be used as the basis to estimate the overall internal condition of a Daikin chiller. The characteristics of the lubricants and refrigerants, and knowledge of the interaction of wear materials in the chiller must be considered when interpreting a wear metal analysis. Periodic oil analysis performed by a reputable laboratory and used in conjunction with compressor vibration analysis and operating log review can be helpful tools in estimating the internal condition of a Daikin chiller.

Daikin recommends that an oil analysis be performed annually. Professional judgment must be exercised under unusual circumstances, for example, it might be desirable to sample the lubricating oil shortly after a unit has been placed back into operation after it has been opened for service, as recommended from previous sample results or after a failure. The presence of residual materials from a failure should be taken into consideration in subsequent analysis. While the unit is in operation, the sample should be taken from a stream of refrigerant oil, not in a low spot / quiet area.

**Table 10 - Upper Limit For Wear Metals And Moisture In Polyolester Oils In Daikin Centrifugal Chillers**

Elements	Upper Limit (ppm)	Action
Aluminum	50	1
Copper	100	1
Iron	100	1
Moisture	150	2 & 3
Silica	50	1
Total Acid Number (TAN)	0.19	3

**Key to Action**

- 1) Re-sample after 500 hours of unit operation.
  - a) If content increases less than 10%, change oil and oil filter and re-sample at normal interval (usually annual).
  - b) If content increases between 11% and 24%, change oil and oil filter and re-sample after an additional 500 hours of operation.
  - c) If content increases more than 25%, inspect compressor for cause.
- 2) Re-sample after 500 hours of unit operation.
  - a) If content increases less than 10%, change filter-drier and re-sample at normal interval (usually annual).
  - b) If content increases between 11% and 24%, change filter-drier and re-sample after an additional 500 hours of operation.
  - c) If content increases more than 25%, monitor for a water leak.
- 3) If TAN is less than 0.10, system is safe as far as acid is concerned.
  - a) For TAN between 0.10 and 0.19, re-sample after 1000 hours of operation.
  - b) For TAN above 0.19, change oil, oil filter, and filter-drier and resample at normal interval

**8.2.2 Changing Oil Filters**

Daikin chillers are at positive pressure at all times and do not leak contaminated moist air into the refrigerant circuit, thereby eliminating the need for annual oil changes. An annual laboratory oil check is recommended to check overall compressor condition.

**CE 079 and Larger Compressors** - The oil filter in these compressors can be changed by simply isolating the filter cavities. Close the oil discharge line service valve at the oil pump (at the filter on CE126). Remove the filter cover; some foaming can occur but the check valve should limit leakage from other compressor cavities. Remove the filter, replace with new element, and replace filter cover using a new gasket. Reopen the valve in the pump discharge line and purge air from the oil filter cavity.

When machine is operated again, the oil level must be checked to determine if oil needs to be added to maintain the proper operating level.

**8.2.3 Refrigerant Cycle**

Maintenance of the refrigerant cycle includes maintaining a log of the operating conditions, and checking that the unit has the proper oil and refrigerant charge.

At every inspection, the oil, suction, and discharge pressures should be noted and recorded, as well as condenser and chiller water temperatures.

The suction line temperature at the compressor should be taken at least once a month. Subtracting the saturated temperature equivalent of the suction pressure from this will give the suction superheat. Extreme changes in subcooling and/or superheat over a period of time will indicate losses of refrigerant or possible deterioration or malfunction of the expansion valves. Proper superheat setting is 0 to 1 °F (0.7 °C) at full load. Such a small temperature difference can be difficult to measure accurately. Another method is to measure the compressor discharge superheat, the difference between the actual discharge temperature and the saturated discharge temperature. The discharge superheat should be between 9 and 15 °F (5 to 8 °C) at full load. The liquid injection must be deactivated (by closing the valve in the feed line) when taking the discharge temperature. The superheat will increase linearly to 55 °F (30 °C) at 10% load. The MicroTech interface panel can display all superheat and subcooling temperatures.

**8.2.4 Electrical System**

Maintenance of the electrical system involves the general requirement of keeping contacts clean and connections tight and checking on specific items as follows:

1. The compressor current draw should be checked and compared to nameplate RLA value. Normally, the actual current will be lower, since the nameplate rating represents full load operation. Also check all pump and fan motor amperages, and compare with nameplate ratings.
2. Inspection must verify that the oil heaters are operative. The heaters are insert-cartridge type and can be checked by ammeter reading. They should be energized whenever power is available to the control circuit, when the oil temperature sensor calls for heat, and when the compressor is inoperative. When the compressor runs, the heaters are de-energized. The Digital Output screen and second View screen on the operator interface panel both indicate when the heaters are energized.
3. At least once a quarter, all equipment protection controls should be made to operate and their operating points checked. A control can shift its operating point as it ages, and this must be detected so the controls can be adjusted or replaced. Pump interlocks and flow switches should be checked to be sure they interrupt the control circuit when tripped.
4. The contactors in the motor starter should be inspected and cleaned quarterly. Tighten all terminal connections.

- The compressor motor resistance to ground should be checked and logged semi-annually. This log will track insulation deterioration. A reading of 50 megohms or less indicates a possible insulation defect or moisture and must be further checked.



**CAUTION**

**Never Megger a motor while in a vacuum. Severe motor damage can result.**

The centrifugal compressor must rotate in the direction indicated by the arrow on the rear motor cover plate, near the rotation sight glass. If the operator has any reason to suspect that the power system connections have been altered, (phases reversed) the compressor must be jogged to check rotation. For assistance, call the local Daikin service location.

**8.2.5 Compressor Maintenance**

In order to work safely on centrifugal compressors, technicians need to be aware that there is a potential risk of the low speed seal trapping pressure in the motor-housing. Refrigerant in the motor housing must be recovered by the evaporator service port through the motor cooling drain line (shut off valve on drain line must remain open). As an alternative the motor housing can be emptied through its pressure port on the inlet cooling-line. Never work on the motor housing if not checked that its pressure is zero bar.

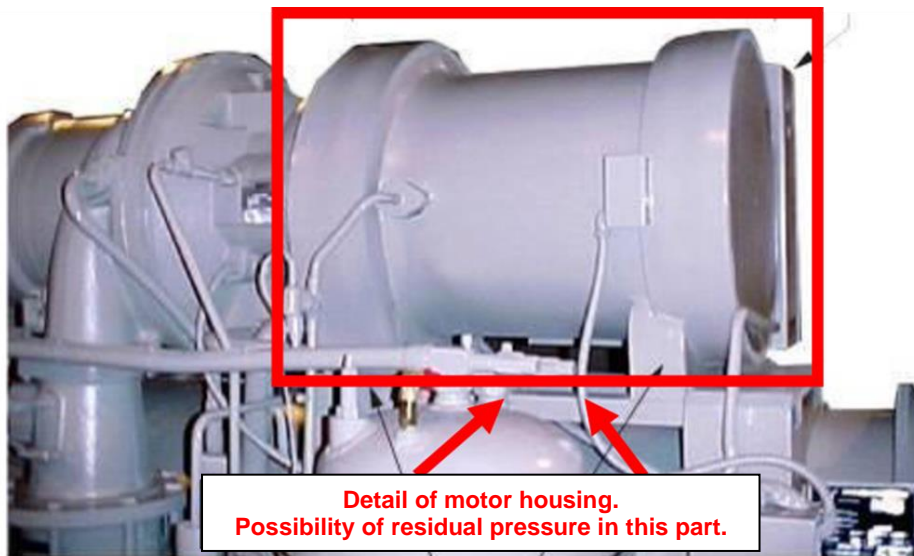


**WARNING**

**Failure to remove all refrigerant pressure from the whole compressor can result in the pressure ejection of components during disassembly operation and cause personal injury.**

**Any work on compressor has to be carried out only by trained technicians, please refer to DAIKIN representative.**

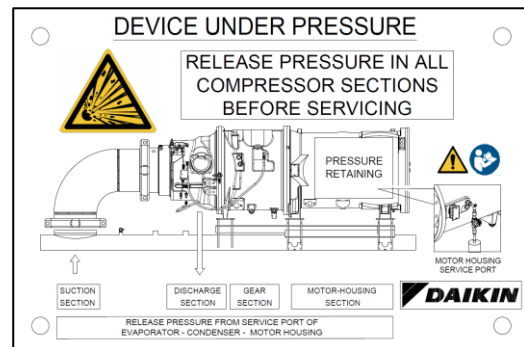
Once recovered the refrigerant from the compressor, service gauges must to be used to check if residual pressure is still present inside the three section of compressor: Suction/Discharge – Gear Box – Motor Housing. Never work on compressor if not checked that its pressure is zero bar in all three sections.



**Detail of motor housing. Possibility of residual pressure in this part.**



**Motor Housing Pressure Port**



**8.2.6 Flanged joints disassembly**

When accessing any flanged connection never loosen and remove individual bolts. Always loosen each bolt slightly and in turn, sequentially, until the flange is clear of the connection. This will retain most of the bolt safety integrity as the flange is removed.

**If pressure should be present, STOP, retighten the bolts and determine why pressure is present.**

### 8.2.7 Cleaning and Preserving

A common cause of service calls and equipment malfunction is dirt. This can be prevented with normal maintenance. The system components most subject to dirt are:

1. Permanent or cleanable filters in the air handling equipment must be cleaned in accordance with the manufacturer's instructions; throwaway filters should be replaced. The frequency of this service will vary with each installation.
2. Remove and clean strainers in chilled water system, oil cooler line and condenser water system at every inspection.

### 8.3 Annual Shutdown

Where the chiller can be subject to freezing temperatures, the condenser and chiller must be drained of all water. Dry air blown through the condenser will aid in forcing all water out. Removal of condenser heads is also recommended. The condenser and evaporator are not self-draining and tubes must be blown out. Water permitted to remain in the piping and vessels can rupture these parts if subjected to freezing temperature.

**Forced circulation of antifreeze through the water circuits is one method of avoiding freeze up.**

1. Take measures to prevent the shutoff valve in the water supply line from being accidentally turned on.
2. Make sure that all the shutoff valves of the unit oil line are closed.
3. If a cooling tower is used, and if the water pump will be exposed to freezing temperatures, be sure to remove the pump drain plug and leave it out so any water that can accumulate will drain away.
4. Open the compressor disconnect switch, and remove the fuses. **If the transformer is used for control voltage, the disconnect must remain on to provide power to the oil heater.** Set the manual UNIT ON/OFF switch in the Unit Control Panel to the OFF position.
5. Check for corrosion and clean and paint rusted surfaces.
6. Clean and flush water tower for all units operating on a water tower. Make sure tower blowdown or bleed-off is operating. Set up and use a good maintenance program to prevent "liming up" of both tower and condenser. It should be recognized that atmospheric air contains many contaminants that increase the need for proper water treatment. The use of untreated water can result in corrosion, erosion, sliming, scaling or algae formation. It is recommended that the service of a reliable water treatment company be used. Daikin assumes no responsibility for the results of untreated or improperly treated water.
7. Remove condenser heads at least once a year to inspect the condenser tubes and clean if required.

### 8.4 Annual Startup

A dangerous condition can exist if power is applied to a faulty compressor motor starter that has been burned out. This condition can exist without the knowledge of the person starting the equipment.

This is a good time to check all the motor winding resistance to ground. Semi-annual checking and recording of this resistance will provide a record of any deterioration of the winding insulation. All new units have well over 100 megohms resistance between any motor terminal and ground.

Whenever great discrepancies in readings occur, or uniform readings of less than 50 megohms are obtained, the motor cover must be removed for inspection of the winding prior to starting the unit. Uniform readings of less than 5 megohms indicate motor failure is imminent and the motor should be replaced or repaired. Repair before failure occurs can save a great deal of time and labor spent in the cleanup of a system after a motor burnout.

1. Make sure that all the shutoff valves of the unit oil line are open.
2. The control circuit must be energized at all times, except during service. If the control circuit has been off and oil is cool, energize oil heaters and allow 24 hours for heater to remove refrigerant from the oil before starting.
3. Check and tighten all electrical connections.
4. Replace the drain plug in the cooling tower pump if it was removed at shutdown time the previous season.
5. Install fuses in main disconnect switch (if removed).
6. Reconnect water lines and turn on supply water. Flush condenser and check for leaks.
7. Refer to the Operating Manual before energizing the compressor circuit.

### 8.5 Repair of System

#### 8.5.1 Pressure Relief Valve Replacement

Current condenser and evaporator designs use two relief valves separated by a three-way shutoff valve (one set). This three-way valve allows either relief valve to be shut off, but at no time can both be shut off. In the event one of the relief valves are leaking in the two valve set, these procedures must be followed:

- If the valve closest to the valve stem is leaking, back seat the three-way valve all the way, closing the port to the leaking pressure relief valve. Remove and replace the faulty relief valve. The three-way shutoff valve must remain either fully back seated or fully forward to normal operation. If the relief valve farthest from the valve stem is leaking, front seat the three-way valve and replace the relief valve as stated above.

#### 8.5.2 Pumping Down

If it becomes necessary to pump the system down, extreme care must be used to avoid damage to the evaporator from freezing. Always make sure that full water flow is maintained through the chiller and condenser while pumping down. To

pump the system down, close all liquid line valves. With all liquid line valves closed and water flowing, start the compressor. Set the MicroTech control to the manual load. The vanes must be open while pumping down to avoid a surge or other damaging condition. Pump the unit down until the MicroTech controller cuts out at approximately 20 psig. It is possible that the unit might experience a mild surge condition prior to cutout. If this should occur, immediately shut off the compressor. Use a portable condensing unit to complete the pump down, condense the refrigerant, and pump it into the condenser or pumpout vessel using approved procedures.

A pressure regulating valve must always be used on the drum being used to build the system pressure. Also, do not exceed the test pressure given above. When the test pressure is reached disconnect the gas cylinder.

### 8.5.3 Pressure Testing

No pressure testing is necessary unless some damage was incurred during shipment. Damage can be determined upon a visual inspection of the exterior piping, checking that no breakage occurred or fittings loosened. Service gauges should show a positive pressure. If no pressure is evident on the gauges, a leak may have occurred, discharging the entire refrigerant charge. In this case, the unit must be leak tested to determine the location of the leak.

### 8.5.4 Leak Testing

In the case of loss of the entire refrigerant charge, the unit must be checked for leaks prior to charging the complete system. This can be done by charging enough refrigerant into the system to build the pressure up to approximately 10 psig (69 kPa) and adding sufficient dry nitrogen to bring the pressure up to a maximum of 125 psig (860 kPa). Leak test with an electronic leak detector. Halide leak detectors do not function with R-134a, R-513A and R-1234ze. Water flow through the vessels must be maintained anytime refrigerant is added or removed from the system.



#### **WARNING**

***Do not use oxygen or a mixture of refrigerant and air to build up pressure as an explosion can occur causing serious personal injury.***

---

If any leaks are found in welded or brazed joints, or it is necessary to replace a gasket, relieve the test pressure in the system before proceeding. Brazing is required for copper joints.

After making any necessary repair, the system must be evacuated as described in the following section.

### 8.5.5 Evacuation

After it has been determined that there are no refrigerant leaks, the system must be evacuated using a vacuum pump with a capacity that will reduce the vacuum to **at least 1000 microns of mercury**.

A mercury manometer, or an electronic or other type of micron gauge, must be connected at the farthest point from the vacuum pump. For readings below 1000 microns, an electronic or other micron gauge must be used.

The triple evacuation method is recommended and is particularly helpful if the vacuum pump is unable to obtain the desired 1 millimeter of vacuum. The system is first evacuated to approximately 29 inches of mercury. Dry nitrogen is then added to the system to bring the pressure up to zero pounds.

Then the system is once again evacuated to approximately 29 inches of mercury. This is repeated three times. The first pulldown will remove about 90% of the noncondensables, the second about 90% of that remaining from the first pulldown and, after the third, only 1/10-1% noncondensables will remain.

### 8.5.6 Charging the System

DWSC water chillers are leak tested at the factory and shipped with the correct charge of refrigerant as indicated on the unit nameplate. In the event the refrigerant charge was lost due to shipping damage, the system should be charged as follows after first repairing the leaks and evacuating the system.

1. Connect the refrigerant drum to the gauge port on the evaporator shutoff valve and purge the charging line between the refrigerant cylinder and the valve. Then open the valve to the mid-position.
2. Turn on both the cooling tower water pump and chilled water pump and allow water to circulate through the condenser and the chiller. (It will be necessary to manually close the condenser pump starter.)
3. If the system is under a vacuum, stand the refrigerant drum with the connection up, and open the drum and break the vacuum with refrigerant gas to a saturated pressure above freezing.
4. With a system gas pressure higher than the equivalent of a freezing temperature, invert the charging cylinder and elevate the drum above the evaporator. With the drum in this position, valves open, water pumps operating, liquid refrigerant will flow into the evaporator. Approximately 75% of the total requirement estimated for the unit can be charged in this manner.
5. After 75% of the required charge has entered the evaporator, reconnect the refrigerant drum and charging line to the service valve on the bottom of the condenser. Again purge the connecting line, stand the drum with the connection up, and place the service valve in the open position.

**IMPORTANT:** At this point, the charging procedure should be interrupted and prestart checks made before attempting to complete refrigerant charge. The compressor must not be started at this time. (Preliminary check must first be completed.)

**NOTE:** It is of utmost importance that all local, national, and international regulations concerning the handling and emission of refrigerants are observed.



## 9 MAINTENANCE SCHEDULE

Maintenance Check List Item	Daily	Weekly	Monthly	Quarterly	Annually	5-Yr	As Required
I. Unit							
• Operational Log	O						
• Analyze Operational Log		O					
• Refrigerant Leak Test Chiller		O					
• Test Relief Valves or Replace						X	
II. Compressor							
• Vibration Test Compressor					X		
A. Motor							
• Meg. Windings (Note 1)					X		
• Ampere Balance (within 10% at RLA)				O			
• Terminal Check (Infrared temperature measurement)					X		
• Motor Cooling Filter Drier Pressure Drop					X		
B. Lubrication System							
• Clean Oil Cooler Strainer (water)					X		
• Oil Cooler Solenoid Operation				O			
• Oil Appearance (clear color, quantity)		O					
• Oil Filter Pressure Drop			O				
• Oil Analysis (Note 5)					X		
• Oil change if indicated by oil analysis							X
III. Controls							
A. Operating Controls							
• Calibrate Temperature Transducers					X		
• Calibrate Pressure Transducers					X		
• Check Vane Control Setting and Operation					X		
• Verify Motor Load Limit Control					X		
• Verify Load Balance Operation					X		
• Check Oil Pump Contactor					X		
B. Protective Controls							
Test Operation of:							
• Alarm Relay				X			
• Pump Interlocks				X			
• Guardistor and Surgeguard Operation				X			
• High and Low Pressure Cutouts				X			
• Oil Pump Pressure Differential Cutout				X			
• Oil Pump Time Delay				X			
IV. Condenser							
A. Evaluation of Temp Approach (NOTE 2)			O				
B. Test Water Quality				V			
C. Clean Condenser Tubes (NOTE 2)					X		X
D. Eddy current Test - Tube Wall Thickness						V	
E. Seasonal Protection							X
V. Evaporator							
A. Evaluation of Temp Approach (NOTE 2)			O				
B. Test Water Quality					V		
C. Clean Evaporator Tubes (NOTE 3)							X
D. Eddy current Test - Tube Wall thickness						V	X
E. Seasonal Protection							X

Maintenance Check List Item	Daily	Weekly	Monthly	Quarterly	Annually	5-Yr	As Required
VI. Expansion Valves							
A.Operational Evaluation (Superheat Control)				X			
VII. Starter(s)							
A. Examine Contactors (hardware and operation)				X			
B. Verify Overload Setting and Trip				X			
C. Test Electrical Connections (Infrared temp measurement)				X			
VIII. Optional Controls							
A. Hot Gas Bypass (verify operation)				X			

**O** = Performed by in-house personnel.

**X** = Performed by Daikin authorized service personnel. (NOTE 4)

**V** = Normally performed by third parties.

**NOTES:**

1. Approach temperature (the difference between the leaving water temperature and the saturated refrigerant temperature) of either the condenser or evaporator is a good indication of tube fouling, particularly in the condenser, where constant flow usually prevails. Daikin's high efficiency heat exchangers have very low design approach temperatures, in the order of one to one and one half °F.

The chiller unit controller can display the water and the saturated refrigerant temperatures. Simple subtraction will give the approach. It is recommended that benchmark readings (including condenser pressure drop to confirm future flow rates) be taken during startup and then periodically afterward. An approach increase of two-degrees or more would indicate that excessive tube fouling could be present. Higher than normal discharge pressure and motor current are also good indicators

2. Evaporators in closed fluid circuits with treated water or anti-freeze are not normally subject to fouling, however it is prudent to check the approach periodically.
3. Performed when contracted for, not part of standard initial warranty service.
4. Oil filter change and compressor teardown and inspection should be done based on the results of the annual oil test performed by a company specializing in this type of test. Consult Daikin Factory Service for recommendations.

## 10 SERVICE PROGRAMS AND WARRANTY STATEMENT

---

It is important that an air conditioning system receive adequate maintenance if the full equipment life and full system benefits are to be realized. Maintenance should be an ongoing program from the time the system is initially started. A full inspection should be made after 3 to 4 weeks of normal operation on a new installation, and on a regular basis thereafter. Daikin offers a variety of maintenance services through the local Daikin service office, its worldwide service organization, and can tailor these services to suit the needs of the building owner. Most popular among these services is the Daikin Comprehensive Maintenance Contract. For further information concerning the many services available, contact your local Daikin service office.

**Consult your local Daikin Representative for warranty details.**

## 11 PERIODIC CHECKS AND COMMISSIONING OF PRESSURE EQUIPMENT

---

The units are included in category IV of the classification according to European Directive PED 2014/68/EU. For chillers belonging to this category, some local regulations require a periodic inspection by an authorized agency. Please check with your local requirements.

## 12 DISPOSAL

---

The unit is made of metal, plastic and electronic parts. All of these components must be disposed of in accordance with local disposal laws and if in scope with the national laws implementing the Directive 2012/19/EU (RAEE).

Lead batteries must be collected and sent to specific waste collection centers.

Avoid the escape of refrigerant gases into the environment by using suitable pressure vessels and tools for transferring the fluids under pressure. This operation must be carried out by competent personnel in refrigeration systems and in compliance with the laws in force in the country of installation.



### 13 IMPORTANT INFORMATION REGARDING THE REFRIGERANT USED

This product contains fluorinated greenhouse gases. Do not vent gases into the atmosphere.

Refrigerant type: R134a / R513A / R1234ze

GWP <sup>(1)</sup> value: 1430 / 631 / 7

<sup>(1)</sup> GWP = global warming potential

The refrigerant quantity necessary for standard operation is indicated on the unit name plate.

Periodic inspections for refrigerant leaks may be required depending on European or local legislation. Please contact your local dealer for more information.

#### 13.1 Factory and Field charged units instructions

The refrigerant system will be charged with fluorinated greenhouse gases, and the factory charge(s) are recorded on the label, shown below, which is adhered inside the electrical panel.

1 Fill in with indelible ink the refrigerant charge label supplied with the product as following instructions:

- any refrigerant charge for each circuit (1; 2; 3) added during commissioning
- the total refrigerant charge (1 + 2 + 3)
- **calculate the greenhouse gas emission with the following formula:**

$GWP * total\ charge\ [kg]/1000$

a                      b    c                      p

Contains fluorinated greenhouse gases      CH-XXXXXXXX-KKKKXX

Factory charge                      Field charge

m ——— **R134a**      1 =  +  kg      d

n ——— GWP: 1430      2 =  +  kg      e

   3 =  +  kg      e

---

1 + 2 + 3 =  +  kg      f

Total refrigerant charge       kg      g

Factory + Field

GWP x kg/1000       tCO<sub>2</sub>eq      h

- a Contains fluorinated greenhouse gases
- b Circuit number
- c Factory charge
- d Field charge
- e Refrigerant charge for each circuit (according to the number of circuits)
- f Total refrigerant charge
- g Total refrigerant charge (Factory + Field)
- h **Greenhouse gas emission** of the total refrigerant charge expressed as tonnes of CO<sub>2</sub> equivalent
- m Refrigerant type
- n GWP = Global Warming Potential
- p Unit serial number



**In Europe, the greenhouse gas emission of the total refrigerant charge in the system (expressed as tonnes CO<sub>2</sub> equivalent) is used to determine the maintenance intervals. Follow the applicable legislation.**

## 14 ANNEX A: ELECTRICAL PANEL

---

DWSC and DWDC chillers can be equipped with a variable frequency drive (VFD), a soft starter (SS) or simply a control panel. A VFD modulates the compressor speed in response to load and evaporator and condenser pressures, as sensed by the compressor controller. Due to the outstanding part load efficiency, and despite the minor power penalty attributed to the VFD, the chiller can achieve outstanding overall efficiency.

VFD really prove their worth when there is reduced load combined with low compressor lift (lower condenser water temperatures) dominating the operating hours. VFD for large capacity compressors over 1200 tons are disproportionately expensive. DAE's dual compressor units (DWDC) with two *half size* compressors allow VFDs to become a reasonable cost alternative on large chillers compared to the very expensive large capacity drives required for competitors' large single compressor chillers.

The traditional method of controlling centrifugal compressor capacity is by variable inlet guide vanes. Capacity can also be reduced by slowing the compressor speed, reducing the impeller tip speed, *providing* sufficient tip speed is retained to meet the discharge pressure (lift) requirements.

This method is more efficient than guide vanes by themselves. In actual practice, a combination of the two techniques is used. The microprocessor slows the compressor (to a fixed minimum percent of full load speed) as much as possible, considering the need for sufficient tip speed to make the required compressor lift. Guide vanes take over to make up the difference in required capacity reduction. This methodology provides the optimum efficiency under any operating condition. The soft starter guarantees a gradual motor starting to preserve the motor and the entire electrical system.

### 14.1 Acceptance of the Product

When the electrical panel is delivered to the place of installation, it must immediately be inspected for damage. All components described in the delivery note must be carefully inspected and checked; any damage must be reported to the carrier. Before unloading the machine, check that the model and the voltage shown on the identity plate correspond to your order. The manufacturer shall accept no liability for any damage which comes to light after acceptance of the machine.

#### 14.1.1 Checks

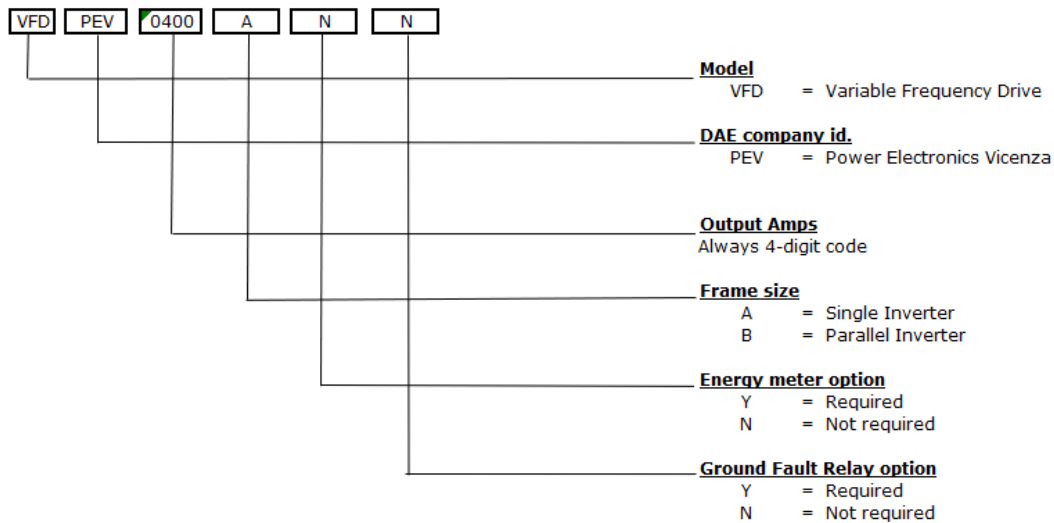
For your own protection in case the machine is incomplete (missing parts) or has been damaged during transport, carry out the following checks upon receipt of the machine:

- a) Before accepting the electrical panel, check every single component of the supply. Check for any damage.
- b) If the electrical panel has been damaged, do not remove the damaged parts. A series of pictures can help to verify responsibility.
- c) Immediately report the extent of the damage to the transport company and request them to inspect the machine.
- d) Immediately inform the dealer of the extent of the damage to allow the latter to arrange for the necessary repairs. Under no circumstances must the damage be repaired before being inspected by a representative of the transport company.

### 14.2 ABBREVIATIONS

EMI	Electromagnetic Interference
IEC	International Electrotechnical Commission
RCD	Residual Current Device
STO	Safe Torque Off (Functional Safety)
CT	Current Transducer
VFD	Variable Frequency Drive

## 14.3 Electrical panel Nomenclature For C Series



## 14.4 Vfds And Distortion

### 14.4.1 VFD Line Harmonics

VFDs have many benefits, but care must be taken when applying VFDs due to the effect of line harmonics on the building electric system. VFDs cause distortion of the AC line because they are nonlinear loads, that is, they don't draw sinusoidal current from the line. They draw their current from only the peaks of the AC line, thereby flattening the top of the voltage waveform. Some other nonlinear loads are electronic ballasts and uninterruptible power supplies.

The integrated DC coils in VFDs allow low harmonic load on the supply line, according to EN 61000-3-12 and also extend the life of the DC circuitry capacitors. They also ensure that the VFD drives the compressor to its full potential. Reflected harmonic levels are dependent on the source impedance and the KVA of the power system to which the drive is connected. Line harmonics and their associated distortion may be critical to AC drive users for three reasons:

1. Current harmonics can cause additional heating to transformers, conductors, and switchgear.
2. Voltage harmonics upset the smooth voltage sinusoidal waveform.
3. High-frequency components of voltage distortion can interfere with signals transmitted on the AC line for some control systems.

The harmonics of concern are the 5th, 7th, 11th, and 13th. Even harmonics, harmonics divisible by three, and high magnitude harmonics are usually not a problem.

### 14.4.2 Current Harmonics

An increase in reactive impedance in front of the VFD helps to reduce the harmonic currents. Reactive impedance can be added in the following ways:

1. Mount the drive far from the source transformer.
2. Use an isolation transformer.
3. Add harmonics mitigation filters.

### 14.4.3 Voltage Harmonics

Voltage distortion is caused by the flow of harmonic currents through a source impedance. A reduction in source impedance to the point of common coupling (PCC) will result in a reduction in voltage harmonics. This may be done in the following ways:

1. Keep the point of common coupling (PCC) as far from the drives (close to the power source) as possible.
2. Increase the size (decrease the impedance) of the source transformer.
3. Increase the capacity (decrease the impedance) of the busway or cables from the source to the PCC.
4. Make sure that the added reactance is "downstream" (closer to the VFD than the source) from the PCC.

### 14.4.4 EMI and RFI Filter

This filter is present as standard inside the VFD. The terms EMI (Electro Magnetic Interference) and RFI (Radio Frequency Interference) are often used interchangeably. EMI is actually any frequency of electrical noise, whereas RFI is a specific subset of electrical noise on the EMI spectrum. There are two types of EMI.

Conducted EMI is unwanted high frequencies that ride on the AC wave form.

Radiated EMI is similar to an unwanted radio broadcast being emitted from the power lines. There are many pieces of equipment that can generate EMI, variable frequency drives included. In the case of variable frequency drives, the electrical noise produced is primarily contained in the switching edges of the pulse width modulation (PWM) controller.

As the technology of drives evolves, switching frequencies increase. These increases also increase the effective edge frequencies produced, thereby increasing the amount of electrical noise. The power line noise emissions associated with variable frequency and variable speed drives can cause disturbances in nearby equipment. Typical disturbances include:

- Dimmer and ballast instability
- Lighting disturbances such as flashing
- Poor radio reception
- Poor television reception
- Instability of control systems
- Flow meter totalizing
- Flow metering fluctuation
- Computer system failures including the loss of data
- Thermostat control problems
- Radar disruption
- Sonar disruption

The combined action of RFI filters and harmonic filters integrated into VFD, allow to keep “clean” mains supply.

The drive conforms to EN 61800-3 EMC product without additional external components and complies with the EMC guidelines 2014/30/EU, providing superior performances. Harmonic inductances integrated as standard, minimize harmonic distortion of the current absorbed by ensuring operations in compliance with the limits imposed by standard EN 61000-3-12.

## 14.5 SAFETY

Installation, start-up and servicing of equipment can be hazardous if certain factors particular to the installation are not considered: operating pressures, presence of electrical components and voltages and the installation site (elevated plinths and built-up up structures). Only properly qualified installation engineers and highly qualified installers and technicians, fully trained for the product, are authorised to install and start-up the equipment safely.

During all servicing operations, all instructions and recommendations, which appear in the installation and service instructions for the product, as well as on tags and labels fixed to the equipment and components and accompanying parts supplied separately, must be read, understood and followed.

Apply all standard safety codes and practices. Wear safety glasses and gloves.

Use the proper tools to move heavy objects. Move units carefully and set them down gently.

### 14.5.1 Avoid electrocution

Only personnel qualified in accordance with IEC (International Electrotechnical Commission) recommendations may be permitted access to electrical components. It is particularly recommended that all sources of electricity to the unit be shut off before any work is begun. Shut off main power supply at the main circuit breaker or isolator.

**IMPORTANT:** This equipment uses and emits electromagnetic signals. Tests have shown that the equipment conforms to all applicable codes with respect to electromagnetic compatibility.



**RISK OF ELECTROCUTION:** Even when the main circuit breaker or isolator is switched off, certain circuits may still be energised, since they may be connected to a separate power source.



**RISK OF BURNS:** Electrical currents cause components to get hot either temporarily or permanently. Handle power cable, electrical cables and conduits, terminal box covers and motor frames with great care.

Always disconnect the electrical panel from the power source before performing any maintenance or adjustment. The electrical panel shall be deemed off when at least one of the following conditions is met:

All fuses connected in series with the power supply have been removed

The main switch is disconnected at all poles

No power is supplied to the electrical panel.

AND

The power supply to the solenoid valve circuit is disconnected

AND

The DC-Link capacitors are discharged



**RISK OF ELECTRIC SHOCK:** Before opening the enclosure, wait at least 20 minutes after disconnecting the power supply, as indicated on the label applied on the Inverter enclosure. This to make sure that all live parts are discharged.

**NOTE:** residual voltage (< 60 V) may still be present across the DC-Link after 20 minutes.

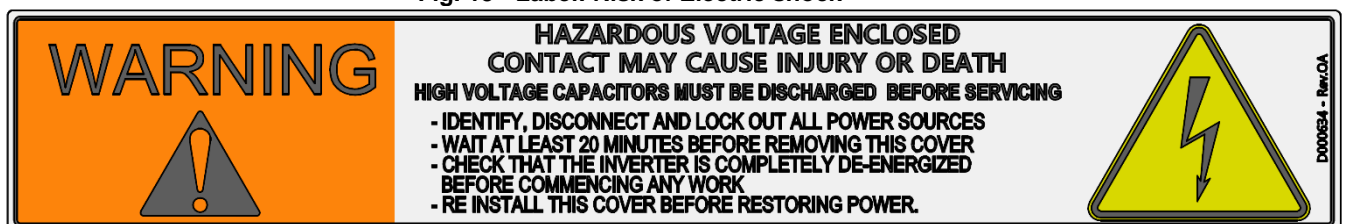
**Never touch the inverter while removing the enclosure. Always check the DC-Link capacitors are discharged at least below 60 V before initiating any operation on the inverter!**

The device without its cover can be accessed only 20 minutes after the power supply has been switched off. This time allows the DC-Link capacitors to be discharged to a safe voltage level.



**RISK OF ARC FLASH:** A substantial amount of energy can be stored in the capacitor bank even if its voltage is below 60 V. Do not short-circuit the DC-Link unless the capacitor bank is completely discharged. Before commencing any mechanical work on the inverter, discharge completely the DC-Link by means of a suitable external device or allow enough time for the DC-Link to be completely discharged (< 5 V).

Fig. 13 - Label: Risk of Electric shock







**WARNING** – Once the cover has been opened, observe ESD precautions and wear protective gloves against electrostatic discharge during maintenance or assembly.



#### 14.5.2 Residual risks

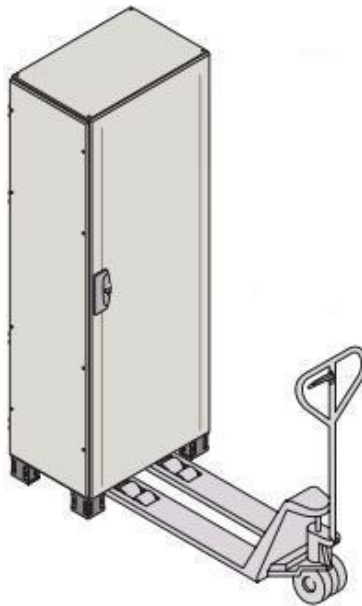
Following the application of the derived corrective / improvement measures of the risk analysis, a series of residual risks have been identified, defined in accordance with the ISO 12100 standard: *risk remaining after protective measures have been implemented.*

- The electrical panel may only be installed in machines designated by the manufacturer Daikin Applied Europe S.p.A. In case of use outside the specifications set out in this manual, the manufacturer's responsibilities Daikin Applied Europe S.p.A. they come to decay.
- PE-ADDA200, PE-ADDA330 and PE-ADDA400 products may only be installed in machines designated by the manufacturer Daikin Applied Europe S.p.A. In case of use outside the specifications set out in this manual, the manufacturer's responsibilities Daikin Applied Europe S.p.A. they come to decay.
- In the assembly and adjustment phases, it is recommended to use suitable tools and PPE (Personal protective equipment) with adequate strength and mechanical protection.
- Before performing any maintenance and / or adjustment operations on the product, make sure that it has been disconnected and that the capacitors have been discharged, as indicated on the warning label on the same.

#### 14.6 HANDLING AND TRANSPORT

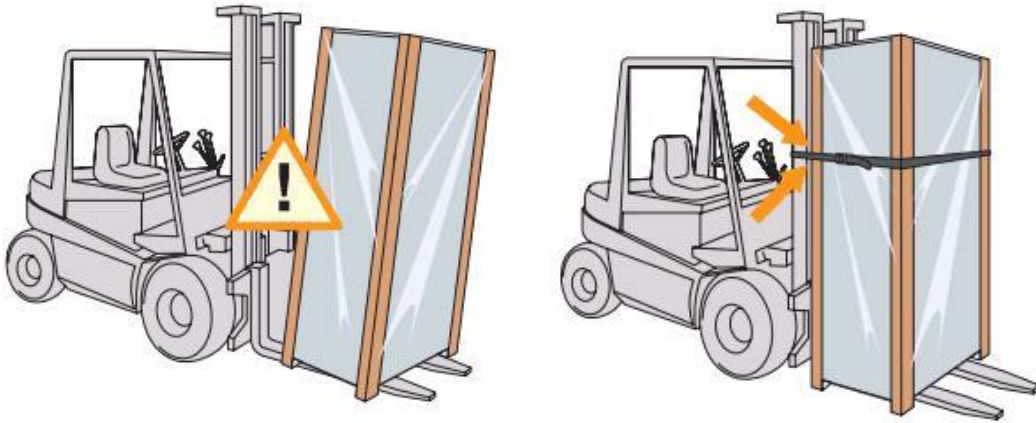
The control panels can be transported, to be located at the place of use, by pallet truck, forklift, crane or bridge crane.

##### Pallet Truck



Check the center of gravity before lifting.

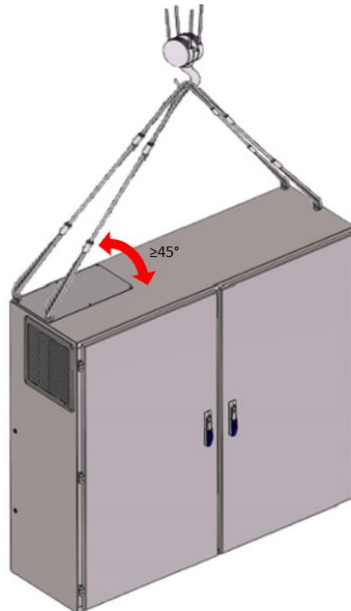
## Forklift



For more safety during transport by forklift, it is recommended ditching the panel to the forklift.

## Crane or Bridge Crane

**Fig. 14 - Angle to respect for lifting operation**



For handling by crane or bridge cranes, before lifting the panel it is necessary to verify the following conditions:

- excellent condition of the ropes or chains;
- the angle between the lifting cables and the panel roof must be  $\geq 45^\circ$ ;
- maximum lifting weight must be respected;

## 14.7 MECHANICAL INSTALLATION

### 14.7.1 Shipping

The stability and the absence of any kind of deformation of the unit during shipping must be ensured. If the machine is shipped with a wooden cross-plank on its base, this cross-plank must only be removed after the final destination has been reached.

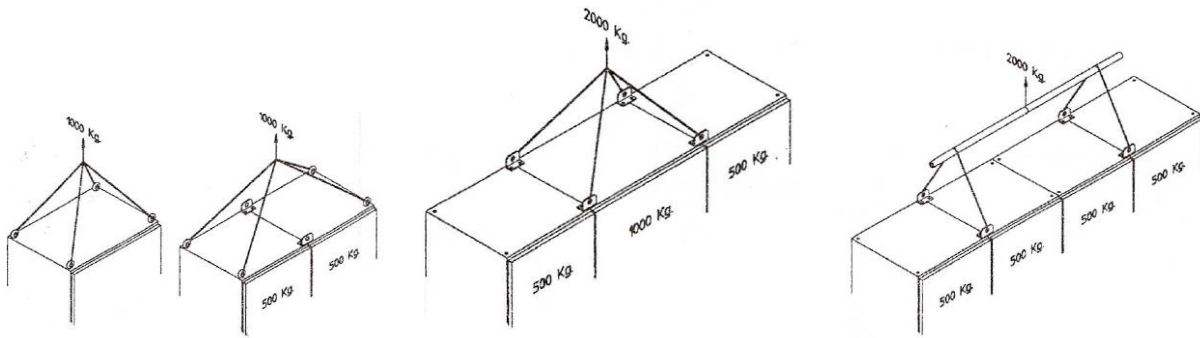
### 14.7.2 Cabinet Handling and Lifting

Avoid bumping and/or jolting during unloading from the lorry and moving the machine. Do not push or pull the machine from any part other than the base frame. Block the machine from sliding inside the lorry in order to prevent damage to the

panels and to the base frame. Avoid any part of the machine falling during unloading and/or moving, as this could cause serious damage.

All units of the series are supplied with four lifting points. Only use these points for lifting the unit, as shown in Fig. 15.

**Fig. 15 - Lifting the VFD**



**WARNING – Both the lifting ropes and the spacing bar and/or scales must be of sufficient size to support the machine safely. Please verify the unit’s weight on the machine’s nameplate. The weights shown in the “Technical data” tables refer to standard units.**

**The machine must be lifted with the utmost attention and care. Avoid jolting when lifting and lift machine very slowly, keeping it perfectly level.**

### 14.7.3 Positioning and assembly

All units are produced for indoor installation. Outdoor installation should be avoided although the cabinet is IP54 rated. The cabinet must be installed vertically on a robust and perfectly level foundation.

To avoid heat sink overheat and/or damage on the installation site, the following precautions and instructions must be followed:

- Avoid air flow recirculation.
- Make sure that there are no obstacles to hamper air flow.
- Air must circulate freely to ensure proper intake and expulsion.

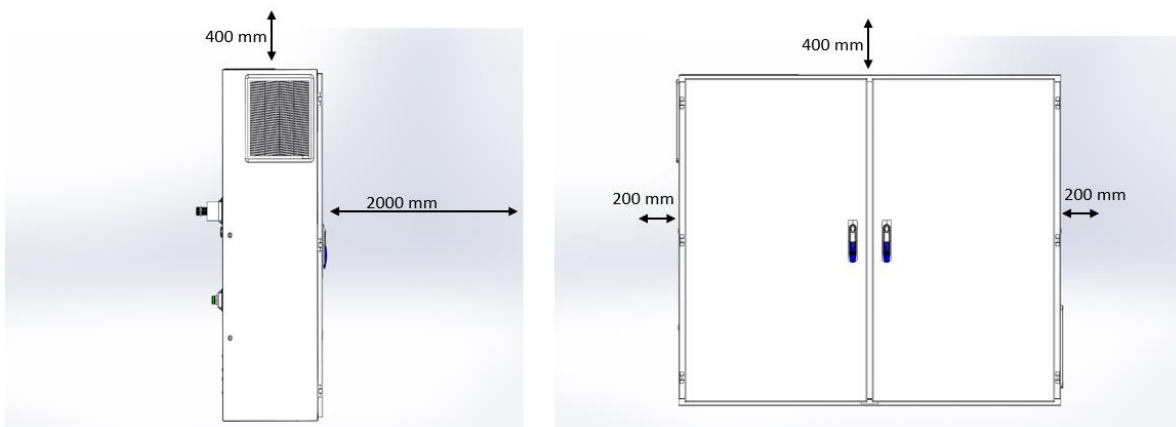
### 14.7.4 Minimum space requirements

It is fundamental to respect minimum distances on all units, in order to ensure optimum ventilation for the electrical panel and to allow easy maintenance. All cabinets have ventilation fans placed in the front door (horizontal air flow) for to keep the electrical panel cold. The air passages must remain absolutely free of obstructions to ensure maximum cooling efficiency. Air filters must be periodically checked and cleaned.

A minimum space on front of the panel must be left in order to allow easy maintenance and repair of cooling fans. Fig. 16 shows the minimum space required.

Should the machine be installed without observing the recommended minimum distances from walls and/or vertical obstacles, there could be a combination of warm air recirculation and/or insufficient supply to the inverter air-cooled heatsink which could overheat the electrical panel.

**Fig. 16 - Minimum space requirements for VFD**



## 14.8 CONTROL PANEL GENERAL SPECIFICATIONS

Only the equipment and components necessary to control the unit are installed inside the electrical panel.

### 14.8.1 Product Identification

The Electrical Panel is identified by its label, which contains the following information:

- Recognized company Trademark
- Panel Model
- Serial Number
- Power Supply
- Rated output current
- Short circuit current
- Weight
- Year

Fig. 177 – Control panel identification Label

 <b>DAIKIN APPLIED EUROPE S.p.A.</b> Via Piani di Santa Maria, 72 00072 Ariccia (Roma), Italia 	
Panel Model	XXX.2
HATA code	
Sales Order Number	
S/N panel	
S/N VFD	
Power Supply	3 x 380-415 V ±10%, 50/60Hz ±5%
Rated Output Current	
Icc	
Weight	
Year	2021
Reference Standards	EN 60204-1:2018 / EN 61439-2:2012

### 14.8.2 Specification

<b>Width [mm]</b>	650
<b>Depth [mm]</b>	431
<b>Height [mm]</b>	1575
<b>Weight [kg]</b>	125
<b>Colour</b>	Ivory White (Munsell code 5Y7.5/1) (±RAL7044)
<b>Material</b>	Galvanized and painted steel sheet
<b>Degree of protection</b>	IP54 (enclosure) – IPXXB (inside panel)
<b>Operating Temperature [°C]</b>	0°C...+42°C
<b>Voltage [V]</b>	380-415V +/-10%
<b>Frequency [Hz]</b>	50/60 +/-5%

### 14.8.3 Directives and Standards

The product is designed according to the following directives.

- 2014/35/EU Low Voltage Directive (LVD)
- 2014/30/UE Electromagnetic Compatibility (EMC)

[https://ec.europa.eu/growth/single-market/europeanstandards/harmonised-standards/electromagnetic-compatibility\\_en](https://ec.europa.eu/growth/single-market/europeanstandards/harmonised-standards/electromagnetic-compatibility_en)

- DIRECTIVE 2011/65/EU RoHS II

Since this product is sold only as a sub-assembly of a compressor, it is out of the scope of Machinery Directive (2006/42/EC) and EMC Directive.

The product has been tested according to the following standards.

- EN 60204-1:2018 Safety of machinery - Electrical equipment of machines - Part 1: General requirements.
- EN 61439-1:2011 Low-voltage switchgear and controlgear assemblies - Part 1: General rules.
- EN 61439-2:2011 Low-voltage switchgear and controlgear assemblies - Part 2: Power switchgear and controlgear assemblies.
- EN61000-6-2 Generic EMC Immunity. Industrial environments.
- EN61000-6-4 Generic EMC Emission. Industrial environments.

## 14.9 SOFT STARTER GENERAL SPECIFICATIONS

The electrical panel contains the equipment and components necessary to control the unit and a soft starter.  
The soft starter installed inside the unit is a technologically advanced equipment that guarantees an high motor protection.

### 14.9.1 Product Identification

The Electrical Panel is identified by its label, which contains the following information:

- Recognized company Trademark
- Panel Model
- Serial Number
- Power Supply
- Rated output current
- Short circuit current
- Weight
- Year

**Fig. 18 - Electrical Panel with soft starter identification Label**

 <b>DAIKIN APPLIED EUROPE S.p.A.</b> Via Piani di Santa Maria, 72 00072 Ariccia (Roma), Italia		
Panel Model	XXX.2	
HATA code		
Sales Order Number		
S/N panel		
S/N VFD		
Power Supply	3 x 380-415 V ±10%, 50/60Hz ±5%	
Rated Output Current		
Icc		
Weight		
Year	2021	
Reference Standards	EN 60204-1:2018 / EN 61439-2:2012	

### 14.9.2 Specification

Size	S1	S2	S3	S4	S5	S6	S7	S8	S9	SA	SB	SC
Model	142	170	210	250	300	370	470	570	720	840	1050	1250
Output Amps [A]	186	242	275	355	433	518	687	845	1027	1201	1515	1788
Width [mm]	1500					2000						
Depth [mm]	510					510						
Height [mm]	1500					1800						
Weight [kg]	280					610						
Colour	Ivory White (Munsell code 5Y7.5/1) (±RAL7044)											
Material	Galvanized and painted steel sheet											
Degree of protection	IP54 (enclosure) – IPXXB (inside panel)											
Operating Temperature [°C]	0°C...+42°C											
Voltage [V]	380-415V +/-10%											
Frequency [Hz]	50/60 +/-5%											
Line cable entry	BOTTOM (op TOP dimensions change)											

### 14.9.3 Directives and Standards

The product is designed according to the following directives.

- 2014/35/EU Low Voltage Directive (LVD)
- 2014/30/UE Electromagnetic Compatibility (EMC)  
[https://ec.europa.eu/growth/single-market/europeanstandards/harmonised-standards/electromagnetic-compatibility\\_en](https://ec.europa.eu/growth/single-market/europeanstandards/harmonised-standards/electromagnetic-compatibility_en)
- DIRECTIVE 2011/65/EU RoHSII

Since this product is sold only as a sub-assembly of a compressor, it is out of the scope of Machinery Directive (2006/42/EC) and EMC Directive.

The product has been tested according to the following standards.

- EN 60204-1:2018 Safety of machinery - Electrical equipment of machines - Part 1: General requirements.
- EN 61439-1:2011 Low-voltage switchgear and controlgear assemblies - Part 1: General rules.
- EN 61439-2:2011 Low-voltage switchgear and controlgear assemblies - Part 2: Power switchgear and controlgear assemblies.
- EN61000-6-2 Generic EMC Immunity. Industrial environments.
- EN61000-6-4 Generic EMC Emission. Industrial environments.

## 14.10 VFD GENERAL SPECIFICATIONS

PE-ADDA200, PE-ADDA330 and PE-ADDA400 are Variable Frequency Drives (VFDs) specific for Daikin Applied Europe Series Compressors.

VFDs are composed of a semi-controlled bridge rectifier, a DC-link, and IGBT power modules. Electronic boards perform power module control and protections.

Control and status of the VFD can be done via digital and analogue I/O, serial bus communication alone or a combination. The serial connection using Modbus (RTU) via RS485 using VFD Nav (Software) gives access to more detailed information of the VFD.

### 14.10.1 Product Identification

The VFD is identified by its label, which contains the following information:

- Recognized company Trademark
- Type: Inverter Model (PE-ADD200, PE-ADD330, PE-ADD400)
- Serial Number
- Application Software
- Production Date
- Input Nominal Ratings
- Output Nominal Ratings

Fig. 19 - VFD Identification Label

		DAIKIN APPLIED EUROPE S.p.A. Power Electronics Division Via Giuseppe Ferrari, 31/37 36100 Vicenza - Italia		Made in ITALY
				
PE-ADDA200AX100C0C - INVERTER 200KW FR3A		INVERTER	25 kg	
S/N	PEV-D002147	CAP. BANK	10 kg	
		TOTAL	35 kg	
VFD200X43AFCD	S/W: c0.52-a1.07-b3 IP00 15/21			
VIN: 3 x (380-480)V ±10%, 50/60Hz	IIN: 420A			
VOU: 3 x 0-0.94VIN, 0-400Hz	IOU: 440A			

The Electrical Panel is identified by its label too, which contains the following information:

- Recognized company Trademark
- Panel Model
- Serial Number
- Power Supply
- Rated output current
- Weight
- Year

Fig. 20 - Electrical Panel (mono) identification Label

		DAIKIN APPLIED EUROPE S.p.A. Power Electronics Division Via Giuseppe Ferrari, 31/37 36100 Vicenza - Italia		
Panel Model	XXX.1			
HATA code				
Sales Order Number				
S/N panel				
S/N VFD				
Power Supply	3 x 380-415 V ±10%, 50/60Hz ±5%			
Rated Output Current				
Weight				
Year	2021			
Reference Standards	EN 60204-1:2018 / EN 61439-2:2012			

Fig. 21 - Electrical Panel (dual) identification Label

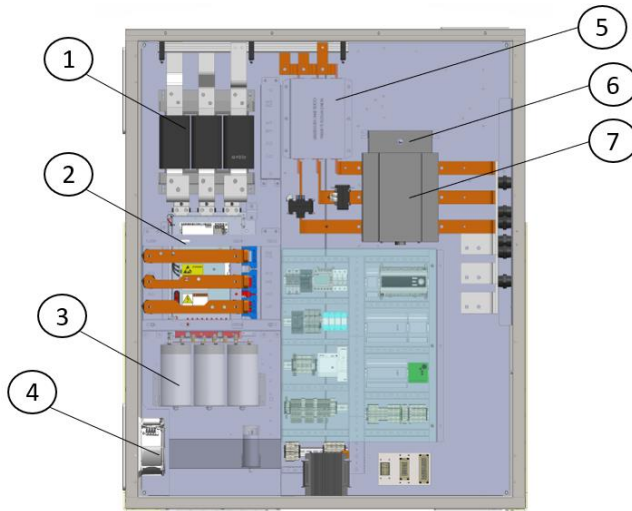
		DAIKIN APPLIED EUROPE S.p.A. Power Electronics Division Via Giuseppe Ferrari, 31/37 36100 Vicenza - Italia		
Panel Model	XXX.2			
HATA code				
Sales Order Number				
S/N panel				
S/N VFD				
Power Supply	3 x 380-415 V ±10%, 50/60Hz ±5%			
Rated Output Current				
Weight				
Year	2021			
Reference Standards	EN 60204-1:2018 / EN 61439-2:2012			



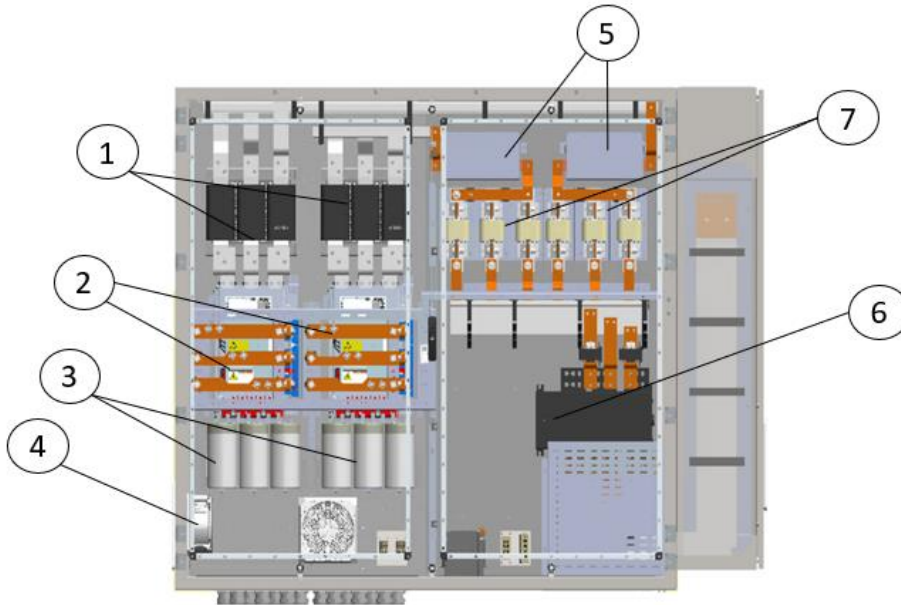
### 14.10.2 Individuation of Parts

VFD panel is composed by the elements shown in Fig. below.

**Fig. 22 - Inverter panel parts (mono)**

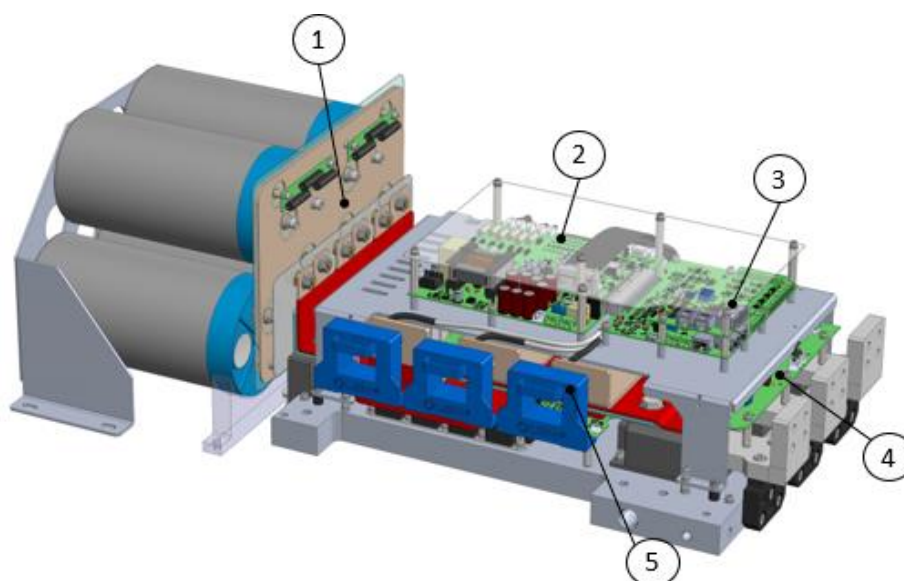


**Fig. 23 - Inverter panel parts (dual)**



Dwg Ref	Description
1	Line reactors
2	VFD
3	Capacitors
4	Fan
5	Filters
6	Main switch
7	Fuses

Fig. 24 - VFD replaceable parts highlighted



Dwg Ref	Part No. (PE-ADDA200)	Part No. (PE-ADDA330)	Part No. (PE-ADDA400)	Description
1	PE-3ACAP012C	PE-3ACAP003C	PE-3ACAP014C	Capacitor Bank (centrifugal)
2	PE-2PWR001_00EC	PE-2PWR001_00FC	PE-2PWR001_00CC	Power Card
3	PE-2REG002_00AC	PE-2REG002_00AC	PE-2REG002_00AC	Regulation Card
4	PE-2FLT005_01AC	PE-2FLT005_01AC	PE-2FLT005_01AC	Filter Card
5	PE-006FV0400T01	PE-006FV0600L01	PE-006FV0600L01	Current Transducer (CT)

### 14.10.3 Specification

DAIKIN VFD PANEL Vintage C		200.1	250.1	330.1	350.1	400.1	
Code DAE-PE		PE-5AE002001XXXX	PE-5AE002501XXXX	PE-5AE003301XXXX	PE-5AE003501XXXX	PE-5AE004001XXXX	
Code DAE-CH		CH-5AE002001XXXX	CH-5AE002501XXXX	CH-5AE003301XXXX	CH-5AE003501XXXX	CH-5AE004001XXXX	
Ratings	Inverter configuration	1 x ADDA200	1 X ADDA330	1 x ADDA330	1 x ADDA400	1 x ADDA400	
	Output Amps (motor selection)	A	400	440	545	600	700
Cabinet	Cabinet Size						
	Width	mm			1500		
	Depth	mm			500		
	Height	mm			1800		
	Weight	kg			600 approx		
	Colour	-			Ivory White (Munsell code 5Y7.5/1) (±RAL7044)		
	Material	-			Galvanized and painted steel sheet		
Degree of Protection	-			IP54 (enclosure) - IPXXB (inside panel)			
Operating Temperature	°C			-10...+45			
Power Supply	Voltage	V		380 - 415V +/- 10%			
	Frequency	Hz		50/60 +/-5%			
Environmental (EN60664-1)				Overvoltage Category III			
				Pollution Degree 2			
Electrical Components	Main switch	-	OS630D03	OS630D03	OS1250D03	OS1250D03	
	Control Transformer	-			115V / 24V		
	Fuse size	-	NH3 500A gG	NH3 630A gG	NH4a 800A gG	NH4a 900A gG	NH4a 900A gG
Filter	Model	-	EPCOS	EPCOS	EPCOS	EPCOS	
	Model (IT OPTION)	-	B84143B0600S080 B84143B0600S081	B84143B0600S080 B84143B0600S081	B84143B0800S080 B84143B0800S081	B84143B0800S080 B84143B0800S081	
PLC on Board + Auxiliary	-	SIEMENS POL688 + TOUCH PANEL EPATEC					
Safety Devices	Safety Stop	-	STO function (not certified)				
	Motor Protection	-	Temperature Electronic Protection / U-V-W Short Circuit Protection / U-V-W Ground Fault Electronic Protection				
	Electrical Hazard Protection	-	Power Off at Door Open				
	Door Interlock	-	Mechanical				
Emergency button	-	YES					
Line reactor	Model	-	1 x 59uH 420A	1 x 43uH 575A	1 x 43uH 575A	1 x 34uH 740A	1 x 34uH 740A
	Line cable entry	-	TOP (opt. BOTTOM)				
Input Cables	size/phase	-	{3x} 2x150 mm <sup>2</sup>	{3x} 2x185 mm <sup>2</sup>	{3x} 2x240 mm <sup>2</sup>	{3x} 2x240 mm <sup>2</sup>	{3x} 2x300 mm <sup>2</sup>
	Ground	-	PE 1x150 mm <sup>2</sup>	PE 1x185 mm <sup>2</sup>	PE 1x240 mm <sup>2</sup>	PE 1x240 mm <sup>2</sup>	PE 1x300 mm <sup>2</sup>
Output Cables	Motor cables exit	-	BOTTOM (left side)				
Cooling System			Expanded Liquid Refrigerant Cooling				
Cooling Fans	Model	-	Fandis 2xFF20A115UE				

DAIKIN VFD PANEL Vintage C			450.2	500.2	540.2	660.2	680.2	800.2
Code DAE-PE			PE-5AE004502XXXX	PE-5AE005002XXXX	PE-5AE005402XXXX	PE-5AE006602XXXX	PE-5AE006802XXXX	PE-5AE008002XXXX
Code DAE-CH			CH-5AE004502XXXX	CH-5AE005002XXXX	CH-5AE005402XXXX	CH-5AE006602XXXX	CH-5AE006802XXXX	CH-5AE008002XXXX
Ratings	Inverter configuration		2 x ADDA200	2 x ADDA200	2 x ADDA330	2 x ADDA330	2 x ADDA400	2 x ADDA400
	Output Amps (motor selection)	A	730	800	900	1090	1200	1400
Cabinet	Cabinet Size							
	Width	mm	2000					
	Depth	mm	500					
	Height	mm	1800					
	Weight	kg	800 approx					
	Colour	-	Ivory White (Munsell code 5Y7.5/1) (±RAL7044)					
	Material	-	Galvanized and painted steel sheet					
	Degree of Protection	-	IP54 (enclosure) - IPXXB (inside panel)					
	Operating Temperature	°C	-10...+45					
Power Supply	Voltage	V	380 - 415V +/- 10%					
	Frequency	Hz	50/60 +/-5%					
Environmental (EN60664-1)			Ovenvoltage Category III Pollution Degree 2					
Electrical Components	Main switch	-	OT1000E03	OT1000E03	OT1250E03	OT1600E03	OT1600E03	OT2000E03
	Control Transformer	-	115V / 24V					
	Fuse size	-	NH3 500A gG	NH3 500A gG	NH3 630A gG	NH4 800A gG	NH4 800A gG	NH4 900A gG
	Fuse holder	-	BB31PP	BB31PP	BB31PP	BB41P	BB41P	BB41P
Filter		-	EPCOS	EPCOS	EPCOS	EPCOS	EPCOS	EPCOS
	Model (IT OPTION)	-	B84143B0600S080 B84143B0600S081	B84143B0600S080 B84143B0600S081	B84143B0600S080 B84143B0600S081	B84143B0800S080 B84143B0800S081	B84143B0800S080 B84143B0800S081	B84143B0800S080 B84143B0800S081
PLC on Board + Auxiliary		SIEMENS POL688 + TOUCH PANEL EPATEC						
Safety Devices	Safety Stop	-	STO function (not certified)					
	Motor Protection	-	Temperature Electronic Protection / U-V-W Short Circuit Protection / U-V-W Ground Fault Electronic Protection					
	Electrical Hazard Protection	-	Power Off at Door Open					
	Door Interlock	-	Mechanical					
Line reactor	Model	-	2 x 59uH 420A	2 x 59uH 420A	2 x 43uH 575A	2 x 43uH 575A	2 x 34uH 740A	2 x 34uH 740A
	Line cable entry	-	BOTTOM (opt. TOP dimensions change)					
Input Cables	size/phase	-	(3x)4x150 mm <sup>2</sup>	(3x)4x150 mm <sup>2</sup>	(3x)4x185 mm <sup>2</sup>	(3x)4x240 mm <sup>2</sup>	(3x)4x240 mm <sup>2</sup>	(3x)4x300 mm <sup>2</sup>
	Ground	-	FE 2x150 mm <sup>2</sup>	FE 2x150 mm <sup>2</sup>	FE 2x185 mm <sup>2</sup>	FE 2x240 mm <sup>2</sup>	FE 2x240 mm <sup>2</sup>	FE 2x300 mm <sup>2</sup>
Output Cables	Motor cables exit	-	BOTTOM (left side)					
Cooling System		-	Expanded Liquid Refrigerant Cooling					
Cooling Fans	Model	-	Fandis 3xFF20A115UE					

#### Notes:

- (1) Switching Frequency range 2.0kHz ÷ 5.0kHz with derating.
- (2) Max altitude (TN-S, TN-C, TN-CS, TT systems): 2000m with no derating; up to 3000m with 1% rated output current derating every 100m.
- (3) Max altitude (IT systems): 2000m with no derating; for installation over 2000m please contact your Daikin Applied representative for instructions.

VFD is designed to be used in TN (grounded neutral point) networks. If installing the VFD in other types of grounded systems, contact your Daikin Applied representative for instructions.

#### 14.10.4 Directives and Standards

The product is designed according to the following directives.

- 2014/35/EU Low Voltage Directive (LVD)
- 2014/30/UE Electromagnetic Compatibility (EMC)  
[https://ec.europa.eu/growth/single-market/europeanstandards/harmonised-standards/electromagnetic-compatibility\\_en](https://ec.europa.eu/growth/single-market/europeanstandards/harmonised-standards/electromagnetic-compatibility_en)
- DIRECTIVE 2011/65/EU RoHS

Since this product is sold only as a sub-assembly of a compressor, it is out of the scope of Machinery Directive (2006/42/EC) and EMC Directive.

The product has been tested according to the following standards.

- EN 60204-1:2018 Safety of machinery - Electrical equipment of machines - Part 1: General requirements.
- EN 61439-1:2011 Low-voltage switchgear and controlgear assemblies - Part 1: General rules.
- EN 61439-2:2011 Low-voltage switchgear and controlgear assemblies - Part 2: Power switchgear and controlgear assemblies.
- EN61000-6-2 Generic EMC Immunity. Industrial environments.
- EN61000-6-4 Generic EMC Emission. Industrial environments.

### 14.10.5 VFD terminals

All VFD configurations are Unit Mounted (UM).

The incoming cable lug size is determined by the device size.

For unit mounted VFDs, the outgoing terminals are connected in factory to the compressor motor.

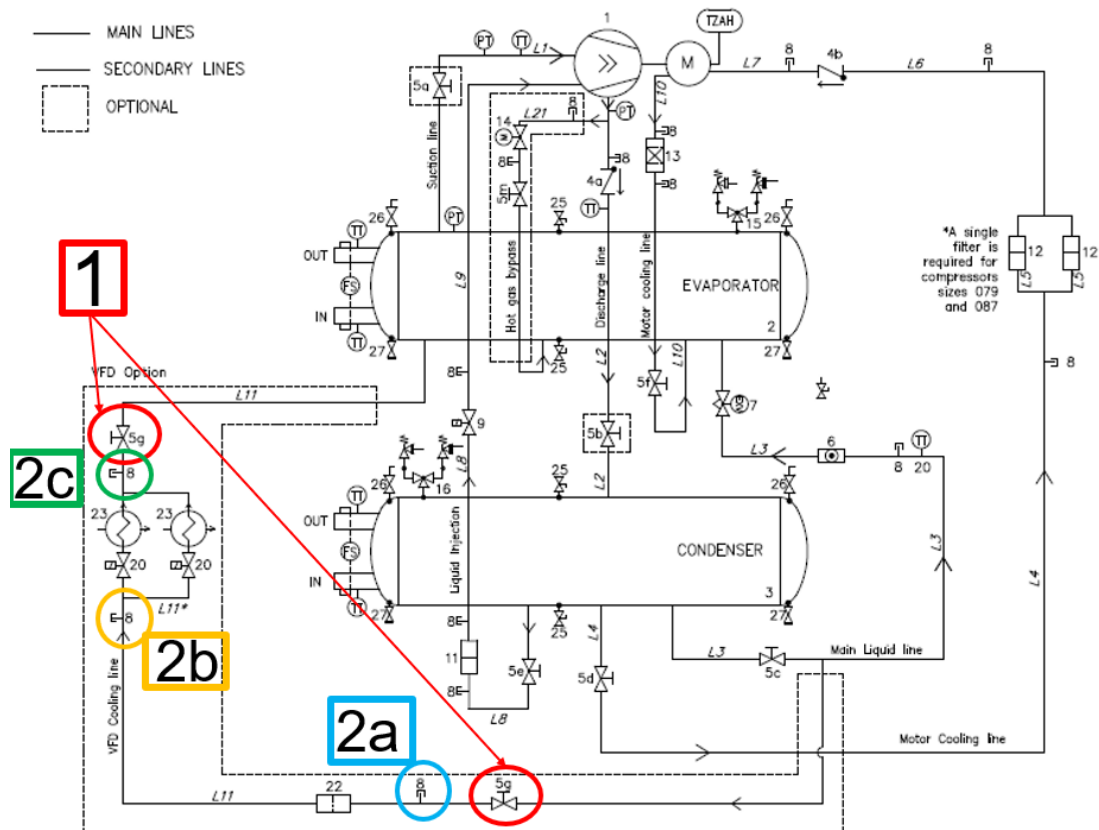
For each phase, cables must be equal length within 10% between inverter and motor terminals.



**Permitted material for conductors: Copper.**

### 14.10.6 Piping Connections

The inverter panel has two copper pipes on his back in which flows some refrigerant taken from the condenser and released in the evaporator. This refrigerant flow is needed to cool down the inverter and avoid it to reach an overtemperature.



**Fig. 25 - P&ID diagram of the unit with inverter cooling line detail**

If inverter panel disconnection is needed it is necessary to avoid that pressure is in these tubes before their removal. To safely disconnect this line, follow the following steps.

- Close the highlighted valves (1 in Fig. ).
- Extract the refrigerant from both the access fittings (2a and 2c in Fig. 25) and measure the pressure. Be sure that there is zero pressure in the lines before proceeding with panel removal.
- Now it is possible to remove the piping from the inverter panel.

Verify that pressure difference between access fitting 2a and access fitting 2b is lower than 2 bar, otherwise provide to filter replacement.



**Failure to remove all refrigerant pressure from the whole refrigerant line can result in the pressure ejection of components during disassembly operation and cause personal injury.**

**Any work on refrigerant lines has to be carried out only by trained technicians, please refer to DAIKIN representative.**

### 14.11 VFD WITH ACTIVE FILTER GENERAL SPECIFICATIONS

PE-ADDA200, PE-ADDA330 and PE-ADDA400 are Variable Frequency Drives (VFDs) specific for Daikin Applied Europe Series Compressors.

VFDs are composed of a semi-controlled bridge rectifier, a DC-link, and IGBT power modules. Electronic boards perform power module control and protections.

Control and status of the VFD can be done via digital and analogue I/O, serial bus communication alone or a combination. The serial connection using Modbus (RTU) via RS485 using VFD Nav (Software) gives access to more detailed information of the VFD.

#### 14.11.1 Product Identification

The VFD with active filter is identified by its label, which contains the following information:

- Recognized company Trademark
- Type: Inverter Model (PE-ADD200, PE-ADD330, PE-ADD400)
- Serial Number
- Application Software
- Production Date
- Input Nominal Ratings
- Output Nominal Ratings

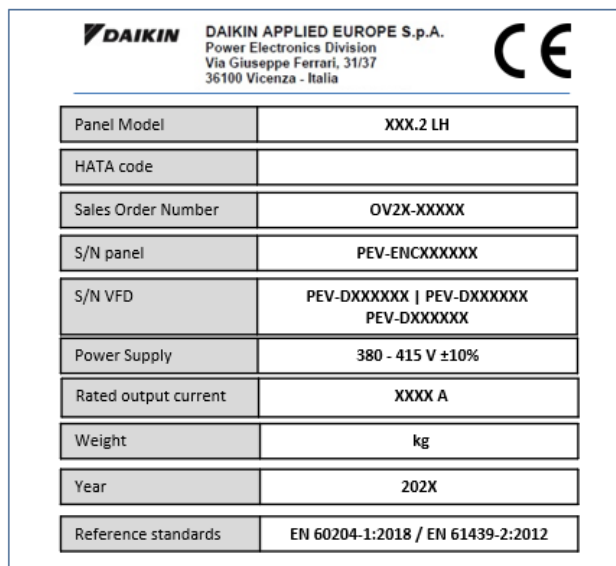
Fig. 26 – VFD Identification Label



The Electrical Panel is identified by its label too, which contains the following information:

- Recognized company Trademark
- Panel Model
- Serial Number
- Power Supply
- Rated output current
- Weight
- Year

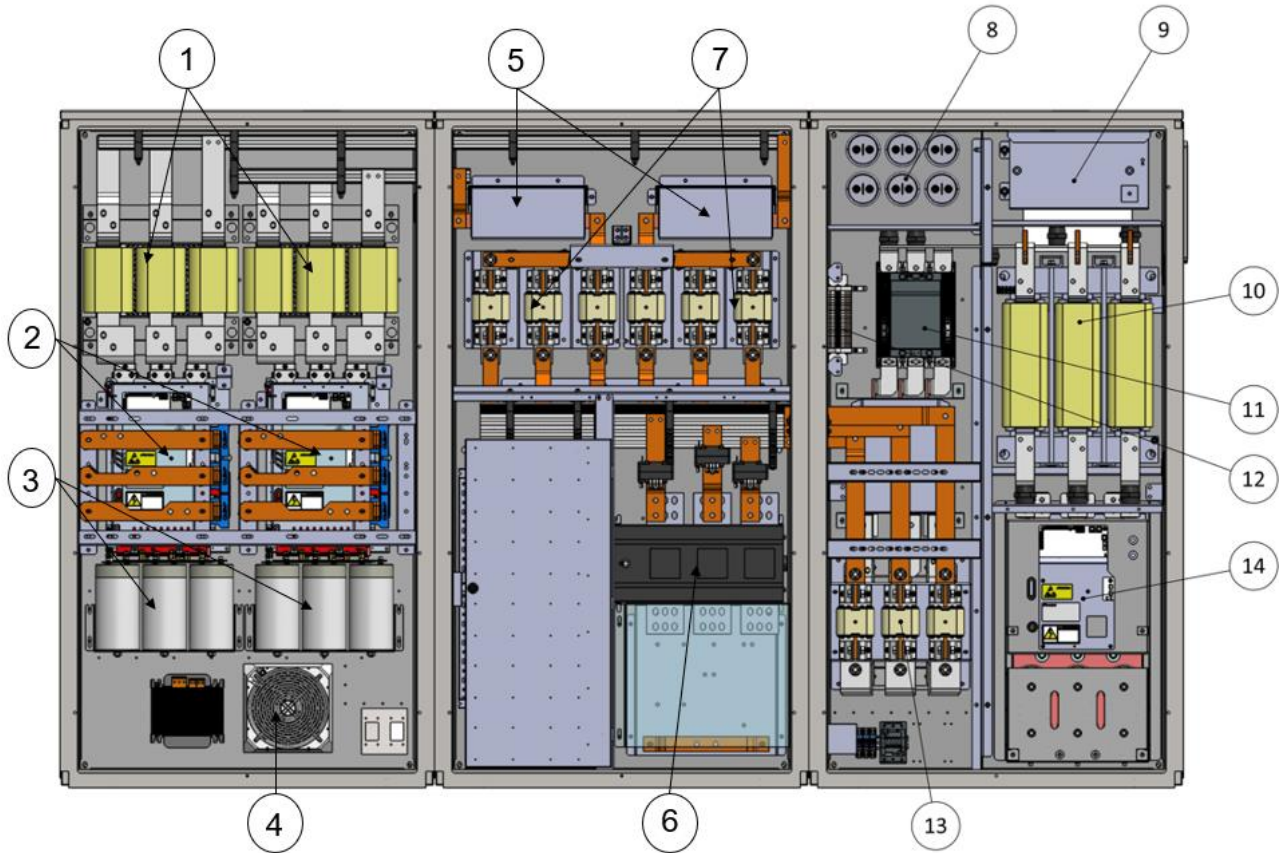
Fig. 2719 - Electrical Panel identification Label



### 14.11.2 Individuation of Parts

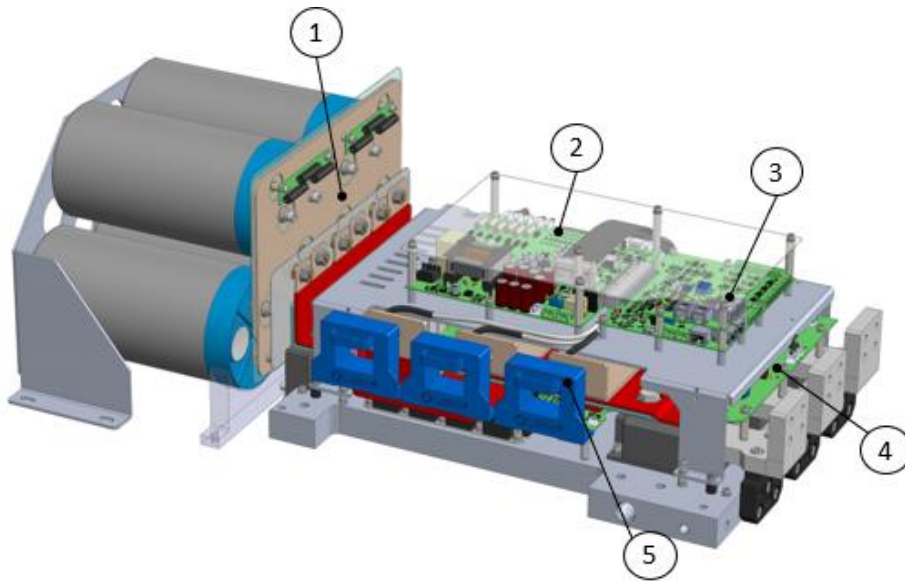
VFD with active filter panel in composed by the elements shown in Fig. below.

Fig. 208 – VFD with active filter panel parts



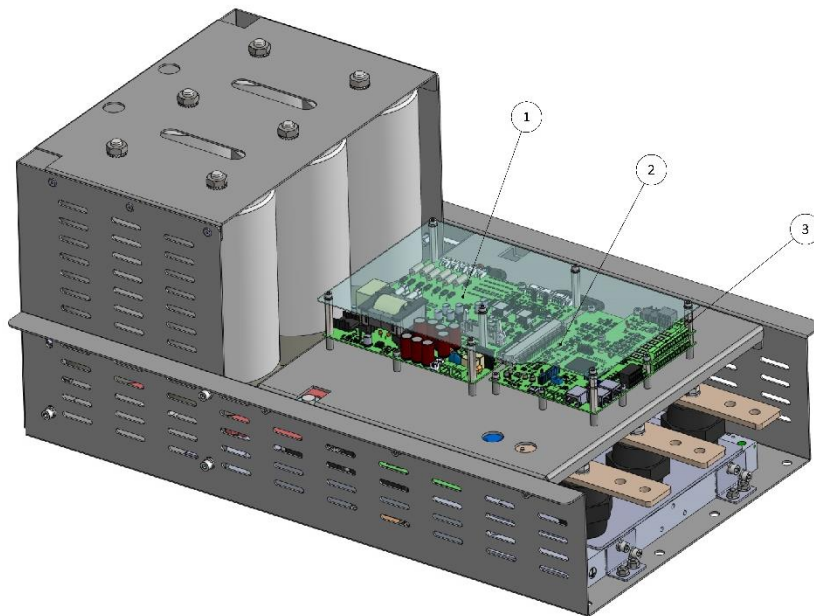
Dwg Ref	Description	Dwg Ref	Description
1	Line reactors	8	LC-filter capacitors
2	VFD	9	LC- filter resistors
3	Capacitors	10	LC- filter reactor
4	Fan	11	Main contactor
5	Filters	12	Pre-charge resisotrs
6	Main switch	13	Fuses
7	Fuses	14	VFD SAF

**Fig. 219 - VFD replaceable parts highlighted**



Dwg Ref	Part No. (PE-ADDA200)	Part No. (PE-ADDA330)	Part No. (PE-ADDA400)	Description
1	PE-3ACAP012C	PE-3ACAP003C	PE-3ACAP014C	Capacitor Bank (centrifugal)
2	PE-2PWR001_00EC	PE-2PWR001_00FC	PE-2PWR001_00CC	Power Card
3	PE-2REG002_00AC	PE-2REG002_00AC	PE-2REG002_00AC	Regulation Card
4	PE-2FLT005_01AC	PE-2FLT005_01AC	PE-2FLT005_01AC	Filter Card
5	PE-006FV0400T01	PE-006FV0600L01	PE-006FV0600L01	Current Transducer (CT)

**Fig. 30 – Active filter replaceable parts highlighted**



Disegno di riferimento	N. parte (PE-ADDA200)	N. parte (PE-ADDA330)	N. parte (PE-ADDA400)	Descrizione
1	PE-2PWR001_00NC	PE-2PWR001_00MC	PE-2PWR001_00LC	Power card LH
2	PE-2REG002_02BC	PE-2REG002_02BC	PE-2REG002_02BC	Regulation card
3	PE-2SAF002B_00AC	PE-2SAF002B_00AC	PE-2SAF002B_00AC	Expansion card for current measure

### 14.11.3 Specification

DAIKIN VFD PANEL LH MODEL			450.2 LH	500.2 LH	540.2 LH	660.2 LH	680.2 LH	800.2 LH	
Code DAE-PE			PE- 5AE014502XXXX	PE- 5AE005002XXXX	PE- 5AE015402XXXX	PE- 5AE016602XXXX	PE- 5AE016802XXXX	PE- 5AE018002XXXX	
Code DAE-CH									
Ratings	Inverter configuration		2x ADDA200		2x ADDA330		2x ADDA400		
	Active filter		1x ADDA200LH		1x ADDA330LH (ADDA400LH)		1x ADDA400LH		
	Output Amps	A	730	800	900	1090	1200	1400	
Size			L6	L7	L8	L9	LA	LB	
Cabinet	Width	mm	3000						
	Depth	mm	600						
	Height	mm	1800						
	Weight	kg	1500			1600		1700	
	Colour		Ivory White (Munsell code 5Y7.5/1) (±RAL7044)						
	Material		Galvanized and painted steel sheet						
	Degree of Protection		IP54 (enclosure) - IPXXB (inside panel)						
Power Supply	Operating Temperature	°C	-10...+45						
	Voltage	V	380 - 415V +/- 10%						
	Frequency	Hz	50/60 +/-5%						
Environmental (EN60664-1)			Overvoltage Category III Pollution Degree 2						
Main switch w/o f.	Model		OT1000E03	OT1000E03	OT1250E03	OT1600E03	OT1600E03	OT2000E03	
EMI Filter	Model		2x B84143B0600S080	2x B84143B0600S080	2x B84143B0600S080	2x B84143B0800S080	2x B84143B0800S080	2x B84143B0800S080	
	Model (IT OPTION)		2x B84143B0600S081	2x B84143B0600S081	2x B84143B0600S081	2x B84143B0800S081	2x B84143B0800S081	2x B84143B0800S081	
Line FUSES	Fuse Model		NH3 500A gG	NH3 500A gG	NH3 630A gG	NH4 800A gG	NH4 800A gG	NH4 900A gG	
	Holder Model		BB31PP	BB31PP	BB31PP	BB41P	BB41P	BB41P	
Control Transformer		V	115V / 24V						
AF FUSES			NH3C 400A gG	NH3C 400A gG	NH3 500A gG	NH3 630A gG	NH3 630A gG	NH4 800A gG	
AF EMI Filter	Model		B84143B0400S080	B84143B0400S080	B84143B0600S080	B84143B0600S080	B84143B0600S080	B84143B0800S080	
	Model (IT OPTION)		B84143B0400S081	B84143B0400S081	B84143B0600S081	B84143B0600S081	B84143B0600S081	B84143B0800S081	
Input Cables	Line Cale Entry		BOTTOM (NO OPTION)						
	Size / Phase		(3x) 4x150 mm2	(3x) 4x150 mm2	(3x) 4x185 mm2	(3x) 4x240 mm2	(3x) 4x240 mm2	(3x) 4x300 mm2	
	PE		2x150 mm2	2x150 mm2	2x185 mm2	2x240 mm2	2x240 mm2	2x300 mm2	
Output Cables	Motor Cables Exit		BOTTOM (left side)						
PLC on Board + Auxiliary			SIEMENS POL688 + TOUCH PANEL						
Safety Devices	Safety Stop		STO function (not certified)						
	Motor Protection		Temperature Electronic Protection / U-V-W Short Circuit Protection / U-V-W Ground Fault Electronic Protection						
	Electrical Hazard Protection		Power Off at Door Open						
	Door Interblock		Mechanical						
	Emergency Button		YES						
Power Losses	Refrigerant	kW	14	14	20	20	24	24	
	Air	kW	2	2	2.5	2.5	3	3	
Cooling System			Expanded Liquid Refrigerant Cooling						
Cooling Fans	Model		Fandis 7x FF20A115UE1						



Notes:

- (1) Switching Frequency range 2.0kHz ÷ 5.0kHz with derating.
- (2) Max altitude (TN-S, TN-C, TN-CS, TT systems): 2000m with no derating; up to 3000m with 1% rated output current derating every 100m.
- (3) Max altitude (IT systems): 2000m with no derating; for installation over 2000m please contact your Daikin Applied representative for instructions.

VFD is designed to be used in TN (grounded neutral point) networks. If installing the VFD in other types of grounded systems, contact your Daikin Applied representative for instructions.

#### 14.11.4 Directives and Standards

The product is designed according to the following directives.

- 2014/35/EU Low Voltage Directive (LVD)
- 2014/30/UE Electromagnetic Compatibility (EMC)  
[https://ec.europa.eu/growth/single-market/europeanstandards/harmonised-standards/electromagnetic-compatibility\\_en](https://ec.europa.eu/growth/single-market/europeanstandards/harmonised-standards/electromagnetic-compatibility_en)
- DIRECTIVE 2011/65/EU RoHS II

Since this product is sold only as a sub-assembly of a compressor, it is out of the scope of Machinery Directive (2006/42/EC) and EMC Directive.

The product has been tested according to the following standards.

- EN 60204-1:2018 Safety of machinery - Electrical equipment of machines - Part 1: General requirements.
- EN 61439-1:2011 Low-voltage switchgear and controlgear assemblies - Part 1: General rules.
- EN 61439-2:2011 Low-voltage switchgear and controlgear assemblies - Part 2: Power switchgear and controlgear assemblies.
- EN61000-6-2 Generic EMC Immunity. Industrial environments.
- EN61000-6-4 Generic EMC Emission. Industrial environments.

### 14.11.5 VFD terminals

All VFD configurations are Unit Mounted (UM).

The incoming cable lug size is determined by the device size.

For unit mounted VFDs, the outgoing terminals are connected in factory to the compressor motor.

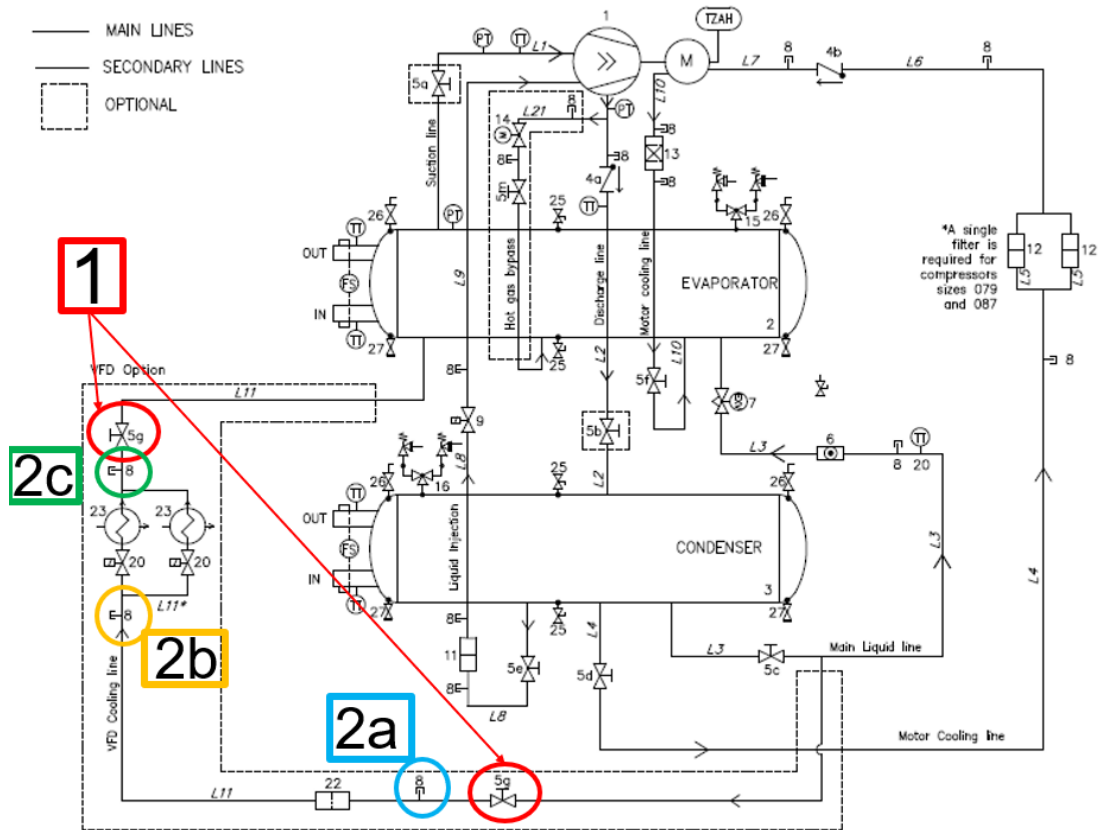
For each phase, cables must be equal length within 10% between inverter and motor terminals.



**Permitted material for conductors: Copper.**

### 14.11.6 Piping Connections

The inverter panel has two copper pipes on his back in which flows some refrigerant taken from the condenser and released in the evaporator. This refrigerant flow is needed to cool down the inverter and avoid it to reach an overtemperature.



**Fig. 31 5 - P&ID diagram of the unit with inverter cooling line detail**

If inverter panel disconnection is needed it is necessary to avoid that pressure is in these tubes before their removal.

To safely disconnect this line, follow the following steps.

- Close the highlighted valves (1 in Fig. 31).
- Extract the refrigerant from both the access fittings (2a and 2c in Fig. 31) and measure the pressure. Be sure that there is zero pressure in the lines before proceeding with panel removal.
- Now it is possible to remove the piping from the inverter panel.

Verify that pressure difference between access fitting 2a and access fitting 2b is lower than 2 bar, otherwise provide to filter replacement.



**Failure to remove all refrigerant pressure from the whole refrigerant line can result in the pressure ejection of components during disassembly operation and cause personal injury.**

**Any work on refrigerant lines has to be carried out only by trained technicians, please refer to DAIKIN representative.**

## 14.12 Maintenance

The maintenance of the product includes the interventions (inspection, verification, control, adjustment and replacement) that are necessary following normal use.

For a good maintenance:

- Use only original spare parts, tools suitable for the purpose and in good condition.
- Comply with the intervention frequencies indicated in the manual for scheduled maintenance (preventive and periodic). The distance (indicated in time or in work cycles) between one intervention and the other is to be understood as maximum acceptable; therefore, it must not be exceeded; it can be abbreviated instead.
- Good preventive maintenance requires constant attention and continuous monitoring of the support. To verify promptly the cause of any anomalies such as excessive noise, overheating, etc. .... and remedy them.
- A timely removal of any causes of anomaly or malfunction avoids further damage to the equipment and ensures operator safety.

The staff in charge of maintenance of the support must be well trained and must have a thorough background knowledge of accident prevention regulations; unauthorized personnel must remain outside the work area during operations. Even the support cleaning activities are carried out only and exclusively during maintenance and with the product de-energized.

The product maintenance operations are divided, from the operational point of view, into two main categories:

Ordinary maintenance	All those operations that the maintenance operator must carry out, in a preventive manner, to guarantee the proper functioning of the support over time; the maintenance ordinary includes inspection, control, adjustment, cleaning and lubrication.
Extraordinary maintenance	All those operations the maintenance technician must carry out when the product needs it. Extraordinary maintenance includes the activities of revision, repair, restoration of nominal or working conditions, replacement of a faulty, defective or worn unit.

### 14.12.1 Ordinary maintenance

Ordinary maintenance includes inspections, checks and interventions that keep an eye on:

- General conditions of the product;
- Power sources (electric);
- Product cleaning.

The following table lists a series of checks and interventions to be performed and a recommended timing. The periodicity of the ordinary maintenance operations indicated refer to normal operating conditions, that is to say responding to the conditions of use envisaged.

OPERATION	FREQUENCY					
	Daily	Weekly	Monthly	Half yearly	Yearly	5 years
Bolts tightening control				X		
Visual inspection of the general condition of the product				X		
Filters check				X		
Filters shaking, blowing and washing					X	
Fans						X

Filters can be washed up to 10 times. Inlet filters could require a higher level of maintenance.

### 14.12.2 Extraordinary maintenance

Any request for extraordinary maintenance must be sent to the manufacturer Daikin Applied Europe S.p.A., who will decide how to proceed. It is recommended not to intervene independently, if the intervention falls outside what is reported in routine maintenance.

## 14.13 VFD COMMUNICATION

### 14.13.1 Modbus RTU Configuration

Protocol	Modbus – RTU
Address	User defined. Default is 1.
Modbus Rate	19200 kbps
Parity	No
Stop Bits	1

**All VFD's come from factory with a default address set to 1. In case a different address must be set, there are two options to set the VFD Modbus address:**

### 14.13.2 Modbus Parameters

Main data exchanged through Modbus are:

Description	Par	Address hex	Address	scale	Type
Active current limitation		0x2000	48192	1	R
Warning status word		0x2001	48193	1	R
STO status word		0x2002	48194	1	R
VFD status word		0x2003	48195	1	R
Allarmi		0x2004	48196	1	R
Regulation Card Temperature	D40	0x2005	48197	16	R
Motor Current	D84	0x2006	48198	10	R
DC Bus Voltage	D67	0x2007	48199	10	R
Actual speed	D21	0x2008	48200	1	R
NTC1 Resistance	D68	0x2009	48201	10	R
NTC1 Temperature	D69	0x200A	48202	10	R
NTC2 Resistance	D70	0x200B	48203	10	R
NTC2 Temperature	D71	0x200C	48204	10	R
PRS1 Voltage	D74	0x200D	48205	100	R
PRS1 Pression	D75	0x200E	48206	100	R
PRS2 Voltage	D76	0x200F	48207	100	R
PRS2 Pression	D77	0x2010	48208	100	R
PRS3 Voltage	D78	0x2011	48209	100	R
PRS3 Pression	D79	0x2012	48210	100	R
Radiator Temperature	D25	0x2013	48211	16	R
EV pulse	D37	0x2014	48212	1	R
Number of Power Holes	D46-D47	0x2015	48213	1	R
Number of solenoid cycles	D38-D39	0x2017	48215	1	R
Motor power	D01	0x2019	48217	16	R
Run command	C21	0x201A	48218	1	R/W
Speed reference	P230	0x201B	48219	1	R/W
DC Min warning threshold	P232	0x201C	48220	10	R/W
DC Max warning threshold	P233	0x201D	48221	10	R/W
VFD Cooling Temp. Reference	P159	0x201F	48223	10	R/W
VFD Start Temperature	P119	0x2020	48224	10	R/W
Capacitors Current	D54	0x2021	48225	40.96	R
VFD Cooling Ripple Reference	P140	0x2022	48226	100	R/W
Max grid amplitude warning	P247	0x2023	48227	10	R/W
Max grid frequency drift warning	P248	0x2024	48228	10	R/W
Max grid unbalance warning	P249	0x2025	48229	10	R/W
Max DC Bus 100 Hz Ripple warning	P250	0x2026	48230	10	R/W
Max Regulation card temperature	P251	0x2027	48231	10	R/W
Grid Amplitude	N50	0x2028	48232	10	R
Grid unbalance	N73	0x2029	48233	10	R
Grid frequency	N51	0x202A	48234	100	R
DC Bus 100Hz ripple	N79	0x202B	48235	16	R
Average Radiator Temperature	N81	0x202C	48236	200	R
Radiator Temperature Ripple	D43	0x202D	48237	100	R
Radiator Cooling Period	N80	0x202E	48238	10	R
Modulation index	D19	0x202F	48239	40.96	R

Description	Par	Address hex	Address	scale	Type
VFD Working hours	D49	0x2030	48240	1	R
Homopolar motor current	N52	0x2031	48241	10	R
Iu true rms	N83	0x2032	48242	16	R
Iv true rms	N84	0x2033	48243	16	R
Iw true rms	N85	0x2034	48244	16	R
Fan working hours	N86	0x2035	48245	1	R
Capacitor temperature	N88	0x2036	48246	10	R
Max DC Bus 100Hz for grid off	P126	0x2037	48247	10	R/W
DC Bus ripple	N92	0x2038	48248	16	R

The status words are defined as follows:

**VFD Status Word (Bit 0 to 15)**

Bit	Status
0	VFD Run
1	Motor (1) / Generator (0) Mode
2	Not used
3	Power Supply Off
4	Not used
5	Alarm Active
6	Not used
7	Not used
8	VFD Ready
9	Not used
10	Power Ready

**VFD Warning Word (Bit 0 to 15)**

Bit	Status
0	DC Bus undervoltage
1	DC Bus overvoltage
2	VFD thermal overload
3	Motor thermal overload
4	VFD overcurrent
5	Radiator too cold
6	VFD current limit
7	VFD torque limit
8	Grid overvoltage
9	Grid unbalanced
10	Grid frequency drift
11	DC Bus ripple too high
12	Regulation overtemperature

The present publication is drawn up by of information only and does not constitute an offer binding upon Daikin Applied Europe S.p.A.. Daikin Applied Europe S.p.A. has compiled the content of this publication to the best of its knowledge. No express or implied warranty is given for the completeness, accuracy, reliability or fitness for particular purpose of its content, and the products and services presented therein. Specification are subject to change without prior notice. Refer to the data communicated at the time of the order. Daikin Applied Europe S.p.A. explicitly rejects any liability for any direct or indirect damage, in the broadest sense, arising from or related to the use and/or interpretation of this publication. All content is copyrighted by Daikin Applied Europe S.p.A..

**DAIKIN APPLIED EUROPE S.p.A.**

Via Piani di Santa Maria, 72 - 00072 Ariccia (Roma) - Italia

Tel: (+39) 06 93 73 11 - Fax: (+39) 06 93 74 014

<http://www.daikinapplied.eu>