

Air Cooled Heat Pump with scroll compressors

EWYT~B-

BLUEVOLUTION

- Nominal heating capacity range 82 - 650 kW
- 2 efficiency levels
- 3 sound configuration
- Full packaged solution
- R-32 HFC refrigerant



Performance according to EN14511.



www.eurovent-certification.com



Low operating cost.

The new Daikin *BLUEEVOLUTION* Heat Pump series (EWYT~B-) is the result of careful design aimed to optimize the energy efficiency and thus the total life cycle cost, with reduced operating cost thanks to outstanding performances and reliability.

The Heat Pump feature high efficiency scroll compressor arranged in tandem or trio configuration on each refrigerant circuit, optimized condensing section with advanced technology condensing fans and plates Water Side Heat Exchanger with low refrigerant content and reduced pressure drops.

Low environmental impact.

Latest revision of F-GAS, entered into force in 2015, set up a phase down program for traditional HFC's refrigerants. In 2018 first significant reduction step will be introduced (37%) and in 2030 the reduction (calculated in equivalent CO2 tons) will need to achieve almost 80%.

HFC's phase down objectives*:



(*) Baseline value (100%) is the annual average of total quantity of CO2 equivalents placed on EU Market from 2009 to 2012

The new Daikin *BLUEEVOLUTION* Heat Pump uses R-32 refrigerant to reduce drastically the carbon footprint of the unit. The selection of R-32 (chemical name difluoromethane) minimises the global warming impact of scroll compressor units thanks to the lower Global Warming Potential in combination with high-energy efficiency. The Global Warming Potential of R-32 is 675, which is only one third of the commonly used refrigerant R-410A.

Thanks to the lower flammability classification (R-32 refrigerant is classified A2L in ISO817), it can be safely used in many applications including chilled water systems. Being a single component refrigerant, R-32 is also easier to recycle and reuse, that is another environmental plus in its favour.

Daikin has a long history of continuous reduction of the environmental impact of cooling, heating and refrigeration, having a unique expertise that comes from manufacturing both refrigerants and equipment. This position is one of the results of company's corporate philosophy to "Be a Company that Leads in Applying Environmentally Friendly Practices".







Regarding refrigerant choice, Daikin has expertise in using fluorinated (HFC, HFO) as well as non-fluorinated gases (ammonia, carbon dioxide, hydrocarbons), because the company believes in diversity of refrigerant choice to allow the best suited solution to be used in each application.

Range overview.

EWYT~B- is available with:

- 2 different layouts: Parallel Coil and Double V Coil.
- 2 Efficiency levels: Gold (high efficiency) and Silver (standard efficiency).
- One or Two independent refrigerant circuits.

BLUEEVOLUTION

Single Circuit	Standard Efficiency Silver 	82-213 [kW] 	-
	High Efficiency Gold 	86-218 [kW] 	-
Dual Circuit	Standard Efficiency Silver 	209-256 [kW] 	300-627 [kW] 
	High Efficiency Gold 	215-261 [kW] 	306-650 [kW] 

- 3 noise versions: Standard, Low and Reduced each one carefully designed to meet the acoustic requirements of the installation site.



Sound Versions	Compressor Acoustic Enclosure	Fan Speed	Compressor Acoustic Enclosure	Fan Speed	Avg Sound Power Reduction
Standard	Not Insulated	Standard	-	Standard	-
Low	Insulated	Standard	Insulated	Standard	-4 dB(A)
Reduced	Insulated	Reduced	Insulated	Reduced	-6 dB(A)

Outstanding reliability.

The unit have one or two truly independent refrigerant circuits with two or three compressors, to assure maximum safety for any maintenance, whether planned or not.

Condensation control.

Parallel Coil units are standardly equipped with continuous fan speed modulation (phase cut) to ensure precise airflow control and optimized condensing temperature. Double V Coil units are equipped with fan speed modulation (VFD) on request (standard on Reduced noise units).

Fan silent mode.

Units equipped with fan modulation are standardly supplied with fan silent mode. This feature allows the user to set up detailed time bands to reduced fan rotation speed and therefore sound emission in those areas where night quietness is a mandatory requirement (detailed values are available on CSS selection software).

Superior control logic.

Superior control logic The MicroTech 4 controller provides an easy to use control environmental. The control logic is designed to provide maximum efficiency, to continue operation in unusual operating conditions and to provide a history of unit operation. One of the greatest benefits is the easy interface with LonWorks, Bacnet, Ethernet TCP/IP or Modbus communications. Integrated sequencing control is provided allowing to connect units (up to 4) operating as a single bigger unit.

Dynamic Condensing Pressure Management.

Superior software logic has been developed to get the highest efficiency at whichever operating condition: thanks to the Dynamic Condensing Pressure Management the unit controller adjusts the condensing pressure set-point to minimize the overall unit power input.

Code requirements – Safety and observant of laws/directives

Units are designed and manufactured in accordance to the following directives and harmonized standards:

Low voltage directive	DIRECTIVE 2014/35/EU
Electromagnetic compatibility (EMC)	DIRECTIVE 2014/30/EU
Machinery directive	DIRECTIVE 2006/42/EC
Pressure equipment desing	DIRECTIVE 2014/68/EU
Ecodesing	DIRECTIVE 2009/125/EC
Safety of machinery	EN 60204-1
EMC - Part 6-2	EN 61000-6-2
EMC - Part 6-4	EN 61000-6-4
Safety and environmental requirements	EN 378-1; EN 378-2; EN 378-4
Methods for calculation pressure relief devices.	EN 13136

Certifications.

Units are CE marked, complying with European directives in force, concerning manufacturing and safety. On request units can be produced complying with laws in force in non-European countries (ASME,go etc.), and with other applications.

Compressors

Hermetic orbiting scroll type designed for R-32 operation and complete with motor over-temperature and over-current protection devices. Each compressor is equipped with an oil heater that keeps the oil from being diluted by the refrigerant when the unit is not running. The compressors are connected in Tandem or Trio configuration on each refrigerant circuit. Each compressor is mounted on rubber antivibration mounts for a quiet operation. Unit is delivered with complete oil charge.

Water Side Heat Exchanger

The unit is equipped with a direct expansion plate-to-plate type Heat Exchanger optimized for R-32 refrigerant operation. This heat exchanger is made of stainless-steel brazed plates and is covered with 20mm closed cell insulation material. The exchanger is equipped with an electric heater for protection against freezing and Heat Exchanger water connections are provided with victaulic kit (as standard). The Water Side Heat Exchanger is manufactured in accordance to 2014/68/EU. The flow switch and the Water Side Heat Exchanger water filter are available as option (shipped loose). The installation of the flow switch and the water filter is mandatory.

Air Side Heat Exchanger

The Air Side Heat Exchanger is manufactured with internally enhanced seamless copper tubes arranged in a staggered row pattern and mechanically expanded into lanced and rippled aluminum Air Side Heat Exchanger fins with full fin collars. An integral sub-cooler circuit provides sub-cooling to effectively eliminate liquid flashing and increase cooling capacity without increasing the power input.

Air Side Heat Exchanger fans

Air Side Heat Exchanger fans are propeller type with high efficiency design blades to maximize performances. The blades are made of glass-reinforced resin and a guard protects each fan.

Parallel Coil units are equipped as standard with fan speed modulation (phase cut).

Double V Coil units (standard and low sound versions) are equipped with on/off fans and inverter drive is available as an option. Double V Coil units reduced noise versions are equipped with inverter driven fans as standard.

Electronic expansion valve

The unit is equipped with electronic expansion valves to achieve precise control of R-32 refrigerant mass flow. As today's systems require improved energy efficiency, accurate temperature control, wide range of operating conditions, the application of electronic expansion valves becomes mandatory.

Electronic expansion valve has unique features: short opening and closing time, high resolution, positive shut-off function to eliminate use of additional solenoid valve, continuous modulation of mass flow without stress in the refrigerant circuit and corrosion resistance stainless steel body.

If compared to traditional thermostatic valves, electronic expansion valves allow the system to work with low Air Side Heat Exchanger pressure (winter time) without any refrigerant flow problems and the perfect control of the chilled water temperature.

Refrigerant circuit

Each unit has one or two independent refrigerant circuits and each one includes:

- Compressor
- Refrigerant
- Water Side Heat Exchanger
- Air Side Heat Exchanger
- Electronic expansion valve
- 4 way valve
- Sight glass with moisture indicator
- Filter drier
- Charging valves
- High pressure switch
- High pressure transducers
- Low pressure transducers
- Oil pressure transducer
- Suction temperature sensor

Electrical panel

Power and control are in the main panel that is manufactured to ensure protection against all weather conditions. The electrical panel is IP54 and (when opening the doors) internally protected against possible accidental contact with live parts. The main panel is fitted with a main switch interlocked door that shuts off power supply when opening.

MicroTech 4 controller

The new MicroTech 4 controller is installed as standard in all Daikin units.

It gives the possibility to check the most relevant control parameters and modify unit set-points. A built-in display shows unit operating status. Additionally, temperatures and pressures of water, refrigerant and air, programmable values, set-points can be accessed based on a preset list of user profiles.

A sophisticated software with adaptive logic, selects the most energy efficient combination of compressors, EEXV and fans to keep stable operating conditions to maximize unit energy efficiency and reliability. MicroTech 4 protects critical components based on external signals from onboard sub-system (such as motor temperatures, refrigerant and oil pressures and temperatures, correctness of phase sequence, pressure switches and freezing of heat exchanger).

The input coming from high-pressure switches cuts all digital output from the controller in less than 50ms, as an additional security for the equipment. Fast program cycle (less than 200ms) for a precise monitoring of the system and sub-systems. Floating point calculations supported for increased accuracy in Pressure / Temperature conversions.

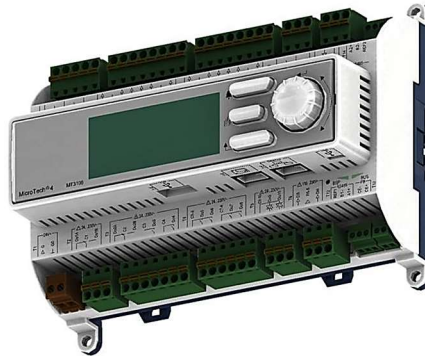

Control main features

Control system has the following feature:

- Management of compressors and fans modulation;
- Control of cooling or heating leaving water temperatures;
- Management of cooling and heating capacities according to the load;
- Switch of operating modes in less than 1 minute;
- Return reset (set point reset based on return water temperature);
- Set point reset (optional);
- Unit operation in partial failure condition;
- Managed operations during critical conditions:
 - High ambient temperature;
 - High thermal load;
 - Startup with high and low differential operating conditions;
 - Startup with high entering water temperature in cooling mode;
 - Startup with low entering water temperature in heating mode;
- Optimized management of compressor load;
- Optimized fan management according to condensing pressure;
- General faults alarm relay;
- Automatic re-start in case of power failure;
- Rapid Restart to recover full load in the shortest possible time for Data Centre application;
- ICM Standard control for multiple units management;
- Soft load (optimized management of the compressor load during the start-up);
- Start at high cold heat exchanger water temperature;

- Visualization of:
 - cooling and heating entering/leaving water temperature of heat exchangers;
 - outdoor ambient temperature;
 - condensing-evaporating temperature and pressure, suction and discharge superheat for each circuit;
 - hours and starts counter for compressors and pumps;
 - status safety devices;

Control additional features

- System upgrade with commercial SD cards;
- Save/Restore of configuration parameters with a commercial SD card;
- Ethernet port for remote or local servicing using standard web browsers;
- Daikin on Site connectivity for cloud based

Safety device / logic for each refrigerant circuit

The following devices / logics are available:

- high pressure (pressure switch);
- high pressure (transducer);
- low pressure (transducer);
- fans circuit breakers;
- high compressor discharge temperature;
- high motor winding temperature;
- phase monitor;
- low pressure ratio;
- high oil pressure drops;
- low oil pressure;
- no pressure changes at start.

System security

The following securities are available:

- phase monitor;
- low ambient temperature lock-out;
- freeze protection.

Regulation type

Proportional integral derivative regulation on the cold heat exchanger leaving water output probe.

MicroTech 4

MicroTech 4 built-in terminal has the following features:

- Liquid crystal display with white back lighting, supports Unicode fonts for multi-lingual;
- Key-pad consisting of 3 keys;
- Push'n'roll control for an increased usability;
- Flash memory to protect the data;
- Password access to modify the setting;
- Application security to prevent application tampering or hardware usability with third party applications;
- Alarm history memory to allow an easy fault analysis.

Supervising systems (on request) MicroTech 4 remote communication

MicroTech 4 can communicate to BMS (Building Management System) based on the most common protocols as:

- ModbusRTU (Native);
- LonWorks,
- BACnet BTP certified over IP and MS/TP (class 4) (Native);
- Ethernet TCP/IP (Native).

Additional information related to F-GAS Regulation (EU) No 517/2014 of the European Parliament and of the Council of 16 April 2014 on fluorinated greenhouse gases and repealing Regulation (EC) No 842/2006

Unit Model	Refrigerant type	Refrigerant GWP	N° of circuits	Refrigerant charge Circuit 1 [kg]	Refrigerant charge Circuit 1 [tCO ₂ Eq]	Refrigerant charge Circuit 2 [kg]	Refrigerant charge Circuit 1 [tCO ₂ Eq]
EWYT085B-SS(L)(R)A1	R32	675	1	11.0	7		
EWYT105B-SS(L)(R)A1	R32	675	1	19.0	13		
EWYT135B-SS(L)(R)A1	R32	675	1	27.0	18		
EWYT175B-SS(L)(R)A1	R32	675	1	27.0	18		
EWYT215B-SS(L)(R)A1	R32	675	1	35.0	24		
EWYT205B-SS(L)(R)A2	R32	675	2	17.5	12	17.5	12
EWYT235B-SS(L)(R)A2	R32	675	2	21.5	15	21.5	15
EWYT255B-SS(L)(R)A2	R32	675	2	21.5	15	21.5	15
EWYT300B-SS(L)(R)A2	R32	675	2	10.0	7	17.5	12
EWYT340B-SS(L)(R)A2	R32	675	2	21.0	14	21.0	14
EWYT390B-SS(L)(R)A2	R32	675	2	35.5	24	35.5	24
EWYT430B-SS(L)(R)A2	R32	675	2	35.5	24	35.5	24
EWYT490B-SS(L)(R)A2	R32	675	2	35.5	24	35.5	24
EWYT540B-SS(L)(R)A2	R32	675	2	35.5	24	35.5	24
EWYT590B-SS(L)(R)A2	R32	675	2	35.5	24	50.0	34
EWYT630B-SS(L)(R)A2	R32	675	2	50.0	34	50.0	34

Unit Model	Refrigerant type	Refrigerant GWP	N° of circuits	Refrigerant charge Circuit 1 [kg]	Refrigerant charge Circuit 1 [tCO ₂ Eq]	Refrigerant charge Circuit 2 [kg]	Refrigerant charge Circuit 1 [tCO ₂ Eq]
EWYT085B-XS(L)(R)A1	R32	675	1	17.0	11		
EWYT115B-XS(L)(R)A1	R32	675	1	29.4	20		
EWYT135B-XS(L)(R)A1	R32	675	1	29.8	20		
EWYT175B-XS(L)(R)A1	R32	675	1	34.5	23		
EWYT215B-XS(L)(R)A1	R32	675	1	44.0	30		
EWYT215B-XS(L)(R)A2	R32	675	2	25.0	17	25.0	17
EWYT235B-XS(L)(R)A2	R32	675	2	25.0	17	25.0	17
EWYT265B-XS(L)(R)A2	R32	675	2	27.5	19	27.5	19
EWYT310B-XS(L)(R)A2	R32	675	2	35.0	24	35.0	24
EWYT350B-XS(L)(R)A2	R32	675	2	35.0	24	35.0	24
EWYT400B-XS(L)(R)A2	R32	675	2	35.0	24	50.0	34
EWYT440B-XS(L)(R)A2	R32	675	2	50.0	34	50.0	34
EWYT500B-XS(L)(R)A2	R32	675	2	50.0	34	64.5	44
EWYT560B-XS(L)(R)A2	R32	675	2	64.5	44	64.5	44
EWYT600B-XS(L)(R)A2	R32	675	2	64.5	44	79.0	53
EWYT630B-XS(L)(R)A2	R32	675	2	79.0	53	79.0	53
EWYT650B-XS(L)(R)A2	R32	675	2	79.0	53	79.0	53

Note: Equipment contains fluorinated greenhouse gases.

Actual refrigerant charge depends on the final unit construction, details can be found on the unit labels.

Nomenclature

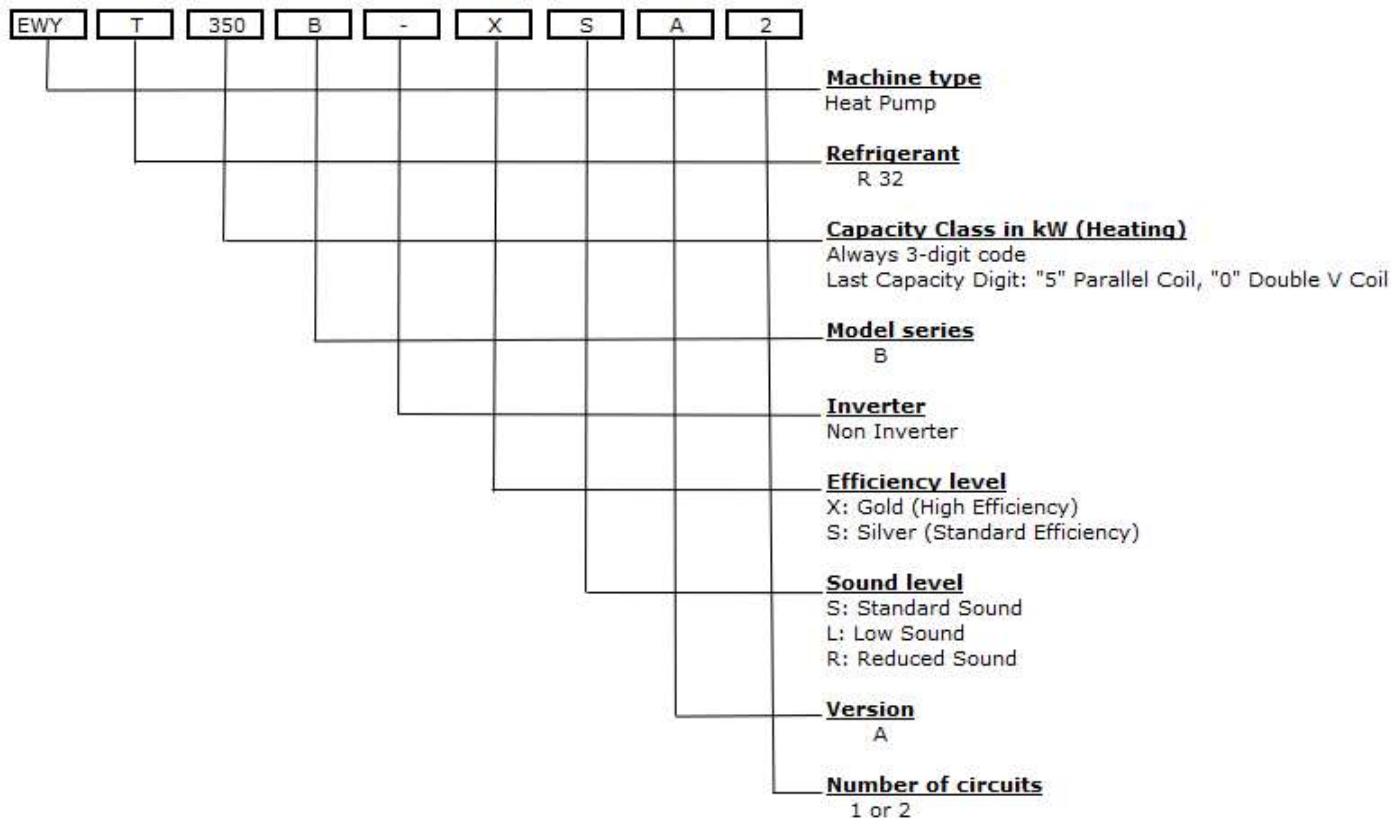

Standard Options (supplied on basic units)

Alucoat fins coil (opt. code 49 – provided as standard)

Fins are protected by a special acrylic paint with a high resistance to corrosion.

Double set point (opt. code 10 – provided as standard)

Possibility to pre-set two different chilled water temperature set points.

Evaporator Victaulic KIT (opt. code 20 – provided as standard)

It includes the victaulic joint and the counter pipe fitted with victaulic groove to be welded with the plant pipes - *Opt. incompatibility 21.*

20mm Evaporator insulation (opt. code 29 - provided as standard)

The heat exchanger is fitted as standard with 20mm closed cell insulation material.

Evaporator electric heater (opt. code 57 – provided as standard)

Electronic expansion valve (opt. code 60 – provided as standard)

Ambient outside temperature sensor and set-point reset (opt. code 67 – provided as standard)

Setpoint Reset: The leaving water temperature set-point can be overwritten through an external 4- 20mA signal, through the ambient temperature, or through the water temperature ΔT .

Hour run meter (opt. code 68 – provided as standard)

General fault contactor (opt. code 69 – provided as standard)

Alarm from external device (opt. code 70)

The unit controller is able to receive an external alarm signal. The user can decide whether this alarm signal will stop the unit or not.

Main switch interlock door (opt. code 97 – provided as standard)

Master / Slave (opt. code 128 – provided as standard)

The EWYT~B features the new DAIKIN Master/ Slave (M/S) control. Once set which unit has the role of master, the other(s) will operate as slave(s) based on the inputs provided by the master. The units must be installed in parallel in the hydronic plant.

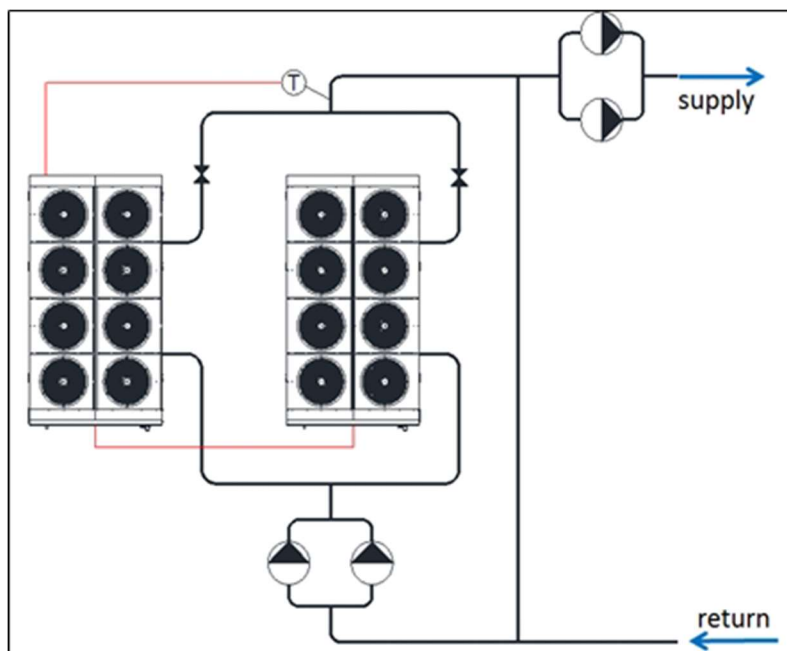

With Master/Slave control is possible to balance the working hours of the compressors enhancing reliability and extending the life of the system

In order to operate in Master/Slave mode an additional probe (PT1000 or NTC10K) must be installed on the common line of the plant and connected to the master unit. The additional probe is not provided by the factory. Master/Slave can manage units selected with pump on board (fix speed pumps). Note: check valves must be installed at the outlet of each unit.

Master/Slave can also manage the start and stop of external pumps (not provided by factory). In this case, the power supply of external pumps is not provided by the unit.

Mechanical Options – On request

Discharge line shut-off valve (opt. code 61)

Installed on the common discharge pipe of the compressors to facilitate maintenance operation (one discharge valve per refrigerant circuit).

Suction line shut-off valve (opt. code 62)

Installed on the common suction pipe of the compressors to facilitate maintenance operation (one suction valve per refrigerant circuit).

Fans circuit breakers (opt. code 96) Opt. incompatibility 99A

Safety devices that, added to the standard protection devices, protect fan motors against overload and overcurrent.

Water filter (opt. code 115)

The water filter removes impurities from water by means of a fine physical barrier. It must be installed on the water pipe connected to the heat exchanger inlet. The filter is shipped loose together with two victaulic joints and two counter pipes to be welded on the plants. NOTE: The installation of the filter is mandatory.

Partial Heat Recovery (opt. code 03A)

A plate to plate heat exchanger for each refrigerant circuit is installed in series to the Air Side Heat Exchanger coil. There is no switch nor solenoid valve in the circuit, thus compressor discharged refrigerant is always flowing through the heat recovery exchanger and hot water production is always available while the unit is providing cooling. During the operation in heat recover the Air Side Heat Exchanger coils provides the sub-cooling ensuring the right amount of liquid at the inlet of the expansion valve. The unit controller manages the condensing temperature set point in order to maximize the cooling effect and amount of energy recovered.

The amount of heat recovered is about the 15/20% (according to the operating conditions) of the total heat rejection of the unit. The unit performs the control on the recovery circuit, based on the return water temperature to the unit. Heat recovery capability is subject to cooling load demand (if no cooling demand is present then no heat recovery is available) - *Opt. incompatibility 134, 135, 136, 137, 120e, 120f, 120g, 120h, 120i, 120j, 120k, 120l.*

Brine Version (OP. code 08)

For operation with temperature at the outlet of the evaporator below +4°C the unit must operate with glycol mixture (with ethylene or propylene glycol) and the Brine Version option must be selected.

Evaporator flange kit (opt. code 21) Opt. incompatibility 20

In case of opt.21 selected, Victaulic connections are still provided. The installation of any Water Filter (to be carried out by the installer) is as follows in the example;

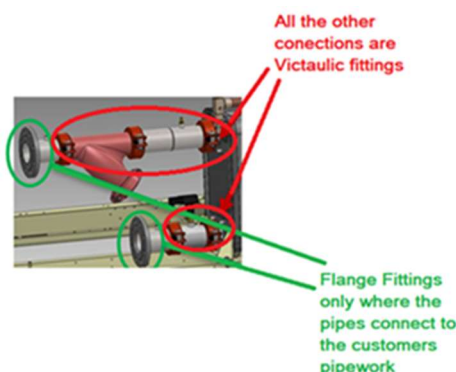

High pressure side manometers (opt. code 63)

Low pressure side manometers (opt. code 64)

Double pressure relief valve with diverter (opt. code 91)

Cu-Cu Condenser coil (opt. code 45)

To give better protection against corrosion by aggressive environments. Not available for parallel coil units - *Opt. incompatibility 46, 49, 117.*

Cu-Cu-Sn Condenser coil (opt. code 46)

To give better protection against corrosion in aggressive environments and by salty air. Not available for parallel coil units - *Opt. incompatibility 45, 49, 117.*

Blygold Coil Treatment (opt. code 117) - It is a Polyurethane coating impregnated with metallic pigment which provides a long lasting corrosion protection to Air Side Heat Exchanger fins coils; it is UV resistant, flexible, heat conductive, chemical resistant to aggressive environments. *Opt. incompatibility 45, 46, 49.*

Hydronic kits Options:

- **One centrifugal pump (Low lift) (opt. code 78)**
- **One centrifugal pump (high lift) (opt. code 79)**
- **Two centrifugal pump (Low lift) (opt. code 80)**
- **Two centrifugal pump (high lift) (opt. code 81)**
- **One centrifugal pump (Low lift) + water tank (opt. code 134)**
- **One centrifugal pump (high lift) + water tank (opt. code 135)**
- **Two centrifugal pump (Low lift) + water tank (opt. code 136)**
- **Two centrifugal pump (high lift) + water tank (opt. code 137)**

Unit mounted hydronic kits are available with single and dual pumps. The Low lift kits provides an average available head of 100 kPa at unit standard conditions. The High lift kits provides an average available head of 200 kPa at unit standard conditions. The kit is completed with pressure gauge, safety valve, drain valve. The motor pump is protected by a circuit breaker installed in control panel. Pump motors are insulation class F, IP55 protected and supplied by the unit with 400V/3ph/50Hz electric current. The kit is assembled and wired to the control panel. In case of unit equipped with hydronic kit on board selected to operate with glycol mixture, contact factory. Water buffer tank volume (if selected), depends on unit model size. For incompatibility refer to the table below:

Option	Description	Incompatibility
78	ONE CENTRIFUGAL PUMP (LOW LIFT)	79 80 81 134 135 136 137 120f 120g 120h 120i 120j 120k 120l
79	ONE CENTRIFUGAL PUMP (HIGH LIFT)	78 80 81 134 135 136 137 120e 120g 120h 120i 120j 120k 120l
80	TWO CENTRIFUGAL PUMP (LOW LIFT)	78 79 81 134 135 136 137 120e 120f 120h 120i 120j 120k 120l
81	TWO CENTRIFUGAL PUMP (HIGH LIFT)	78 79 80 134 135 136 137 120e 120f 120g 120i 120j 120k 120l
134	ONE CENTRIFUGAL PUMP (LOW LIFT) + TANK	03A 78 79 80 81 135 136 137 120e 120f 120g 120h 120j 120k 120l
135	ONE CENTRIFUGAL PUMP (HIGH LIFT) + TANK	03A 78 79 80 81 134 136 137 120e 120f 120g 120h 120i 120k 120l
136	TWO CENTRIFUGAL PUMP (LOW LIFT) + TANK	03A 78 79 80 81 134 135 137 120e 120f 120g 120h 120i 120j 120l
137	TWO CENTRIFUGAL PUMP (HIGH LIFT) + TANK	03A 78 79 80 81 134 135 136 120e 120f 120g 120h 120i 120j 120k

Refrigerant leak detection (opt. code 121 - Available only on units with compressors’ enclosure)

Automated permanent refrigerant leak detection system installed on board. The refrigerant sensors are installed within the compressor enclosures and are specifically calibrated for R-32 refrigerant. When leaks above a certain concentration are detected, the sensor provides a signal to the unit controller (a specific alarm is visualized on the unit microprocessor). The automatic shut down and pump down of refrigerant into the condensing section occurs on the detection of refrigerant leakage. The alarm threshold that triggers automatic pump down upon detection of refrigerant is set to a maximum of 500ppm. Available only on units with compressors’ enclosure.

Electrical options – On request

Compressor thermal overload relays (opt. code 11 – Double V Coil units only)

Available on Double V Coil units only. - *Opt. incompatibility 95*

Under over voltage control (opt. code 15)

Electronic device that monitors and displays input voltage. It stops the unit in case of phase loss, wrong phase sequence, or voltage exceeding minimum and maximum allowed values.

Energy meter (opt. code 16)

Device installed inside the control box that displays units' electrical power parameters such as input line voltage and phase current, input active and reactive power, active and reactive energy. An integrated RS485 module allows a Modbus communication to an external BMS.

Speedtrol (opt. code 42 – Double V Coil units only)

Opt. incompatibility 99, 99a, 142A, 142B, 160, 160C, 161B

Continuous fan speed regulation on the first fan (VFD driven) of each circuit. It allows unit operation down to -18°C (available for standard and low sound version).

Evaporator flow switch (opt. code 58)

On double V coil units, it is supplied separately to be wired and installed on the Water Side Heat Exchanger water piping (by the customer). On parallel coil units, it is mounted and cabled. The installation of the flow switch in mandatory.

Compressors circuit breakers (opt. code 95)

Safety devices that include in a single device all safety functions otherwise provided by standard fuses and optional thermal relays, such as protection against overcurrent, overload, current unbalance

Opt. incompatibility 11

Fans speed regulation (opt. code 99 and 99a)

Fans speed regulation: continuous modulation of the fans' speed for optimal condensation control at low ambient temperatures.

Fans silent mode: This feature allows the user to set up customized time bands to reduced fans' speed rotation and therefore sound emission in those areas where quiet is a mandatory requirement during specific time of the day (e.g. night operation).

Note: option 99 is standard on Parallel Coil units (phase cut). - *Opt. incompatibility 42, 142B, 160C, 161B*

Note: option 99a is standard on Double V Coil V units reduced sound (inverter). - *Opt. incompatibility 42, 96,, 142A 142B, 160, 160C, 161B.*

Ground fault relay (opt. code 102 – Double V Coil units only)

To shut down the unit in case of a ground fault condition is detected.

Nordic kit (opt. 114)

This option is offering on Double V Coil models enhanced drain pans and water discharge line, electric heaters on the pans protected by insulating material and additional covers for plugs at the back side of the electrical panel. Recommended for cold regions installations. For Parallel coil models there is only an additional refrigerant circuit insulation.

HIGH AMBIENT KIT (OP. code 142A) - OP. incompatibility 42 99a 142B 142C 160 160B 160C 161B

The high ambient kit allows to increase the maximum operating ambient temperature for all the Parallel Coil units. Minimum ambient temperature in Cooling is -10°C. Check the unit operating envelope and CSS for more information. This option may increase the height of the unit.

HIGH AMBIENT KIT (OPERATION ABOVE 46°C ON-OFF FANS) (OP. code 142B)

OP. incompatibility 42 99 99a 142A 142C 160 160B 160C 161B

The high ambient kit allows to increase the maximum operating ambient temperature for all the Double V Coil units, with Standard and Low Sound Configurations.

Minimum ambient temperature in Cooling is +10°C. Check the unit operating envelope and CSS for more information. This option may increase the height of the unit.

HIGH AMBIENT KIT (OPERATION ABOVE 46°C BRUSHLESS FANS) (OP. code 142C)

OP. incompatibility 42 99 99a 142A 142B 160 160B 160C 161B

The high ambient kit allows to increase the maximum operating ambient temperature for all the Double V Coil units, with Reduced Sound Configuration.

Minimum ambient temperature in Cooling is -18°C. Check the unit operating envelope and CSS for more information. This option may increase the height of the unit.

VERSION	HIGH AMBIENT KIT	HIGH AMBIENT KIT
PARALLEL COIL LAYOUT SS/SL	OP.142A	NA
PARALLEL COIL LAYOUT SR	OP.142A	NA
PARALLEL COIL LAYOUT XS/XL	OP.142A	NA
PARALLEL COIL LAYOUT XR	OP.142A	NA
VERSION	HIGH AMBIENT KIT	HIGH AMBIENT KIT
DOUBLE V COIL LAYOUT SS/SL	NA	OP.142B
DOUBLE V COIL LAYOUT SR	NA	OP.142C
DOUBLE V COIL LAYOUT XS/XL	NA	OP.142B
DOUBLE V COIL LAYOUT XR	NA	OP.142C

100 PA ESP FANS (OP. code 160 – Parallel Coil units only)

OP. incompatibility 99a 42 142A 142B 142C 160B 160C 161B

Special ON/OFF fans providing 100 Pa ESP. The envelope doesn't change if the option is selected. Check the CSS for more information. This option may increase the height of the unit.

100 Pa ESP (INVERTER FANS) (OP. code 160B – XS/XL Double V Coil units only)

OP. incompatibility 99 99a 42 142A 142B 142C 160 160C 161B

Special VFD fans providing 100 Pa ESP. The envelope doesn't change if the option is selected. Check the CSS for more information. This option may increase the height of the unit.

100 Pa ESP (BRUSHLESS FANS) (OP. code 160C – SS/SL Double V Coil units only)

OP. incompatibility 99 99a 42 142A 142B 142C 160 160B 161B

Special Brushless fans providing 100 Pa ESP. The envelope doesn't change if the option is selected. Check the CSS for more information. This option may increase the height of the unit.

200 PA ESP (BRUSHLESS FANS) (OP. code 161B – Double V Coil units only)

OP. incompatibility 42 99 99a 142A 142B 142C 160 160B 160C

Special Brushless fans providing 200 Pa ESP. The envelope doesn't change if the option is selected. Check the CSS for more information. This option may increase the height of the unit.

VERSION	100Pa ESP ON/FF FANS (OP.160)	100Pa ESP FANS + FAN MOD (OP.160B/C)	200Pa ESP FANS + FAN MOD (OP.161B)
PARALLEL COIL LAYOUT SS/SL	OP.160	NA	NA
PARALLEL COIL LAYOUT SR	NA	NA	NA
PARALLEL COIL LAYOUT XS/XL	OP.160	NA	NA
PARALLEL COIL LAYOUT XR	NA	NA	NA
VERSION	100Pa ESP ON/FF FANS (OP.160)	100Pa ESP FANS + FAN MOD (OP.160B/C)	200Pa ESP FANS + FAN MOD (OP.161B)
DOUBLE V COIL LAYOUT SS/SL	NA	OP.160C	OP.161B
DOUBLE V COIL LAYOUT SR	NA	NA	NA
DOUBLE V COIL LAYOUT XS/XL	NA	OP.160B	OP.161B
DOUBLE V COIL LAYOUT XR	NA	NA	NA

Control variable flow on primary loop based on chiller delta-T (available as standard for single chiller installation only)

Providing the unit with the inverter kit for the on-board pump it is possible to manage a variable water flow rate for the primary loop. This function is available as standard when the hydronic kit plus inverter are selected.

The standard feature is applicable for single unit installation only. In case of multiple chillers installation an additional control is needed.

The variable flow control is suitable for primary/secondary plant, cannot be used in primary plant only.

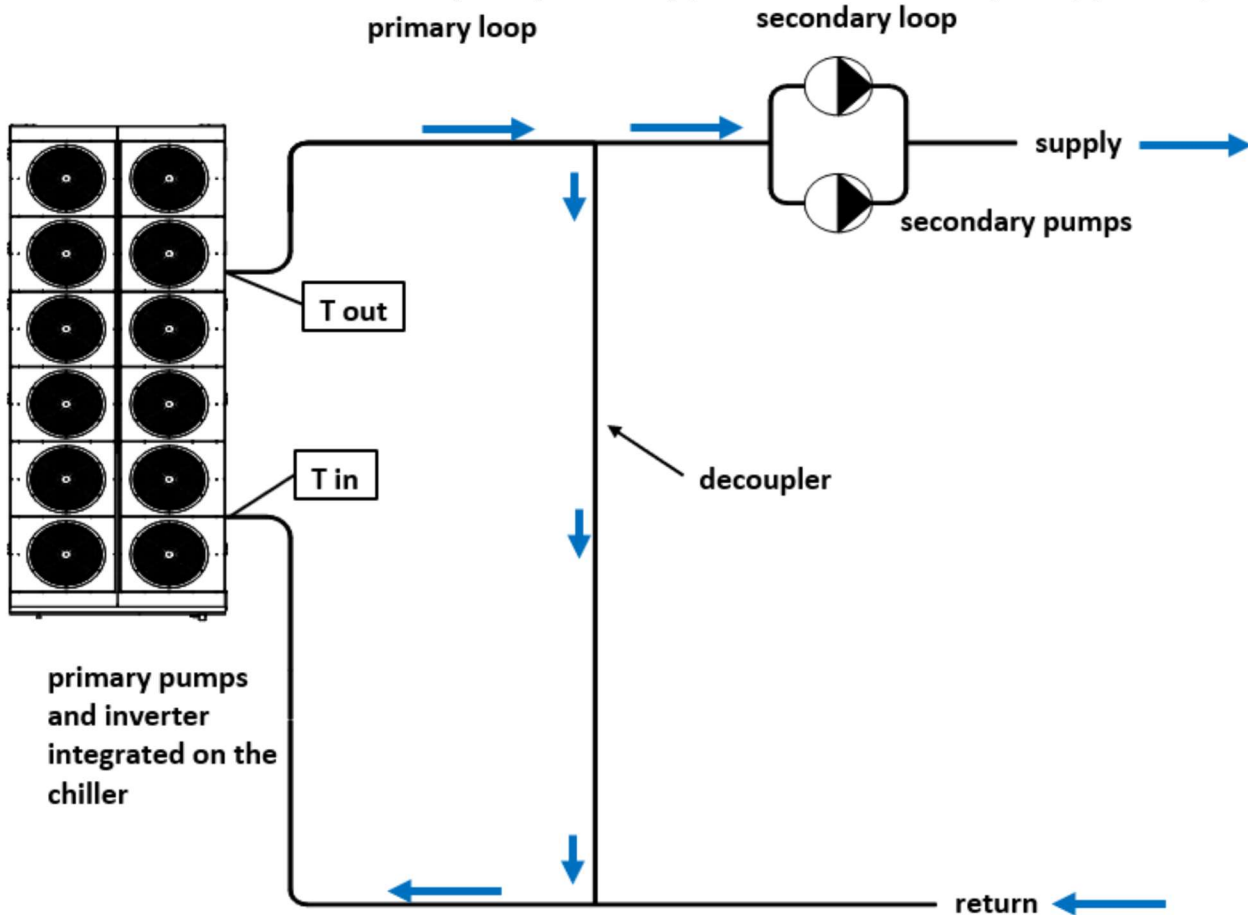

In a Primary-Secondary plant configuration a key component is the decoupler. The decoupler is always open (no valve must be installed). The aim of the decoupler is to allow the primary and secondary pumps to operate at different flow rates. This is necessary because the primary pumps and secondary pumps are managed differently and so the primary and secondary flow rates are practically never the same. Specifically, the primary flow rate is managed based on the chiller delta-T ($T_{out} - T_{in}$), the secondary flow rate is regulated to maintain the necessary pressure differential in the secondary loop. The direction of the water flow through the decoupler must be always from supply to return. To ensure this the primary flow rate must be greater than the secondary flow rate. If this condition is not respected the warmer return water will flow backwards through the decoupler and raise the supply water temperature. Due to the higher temperature of the supply water temperature the terminal unit control will open the valves asking for higher water flow rate. The secondary pumps will speed up increasing even more the water flow rate on secondary plant making the situation even worse (secondary flow rate \gg primary flow rate). As a result there will be no control on the supply water temperature losing effectiveness of the cooling plant.

On the other side any excess in the primary flow, vs. secondary flow, flows through the decoupler from the supply to the return mixing with the warmer return water. To reach this target it is very important to have a minimum pressure drop in the decoupler that needs to be sized to reach a pressure drop that should not exceed 4-5 kPa at the minimum for the flow rate of the primary pump.

Activating the variable flow control the chiller will modulate the water flow rate based on the chiller delta.

When the secondary loop will reduce the water flow rate (because the plant load decreases), the water flow rate in the decoupler (always from supply to return) increases. The return water temperature mixes with the supply water from the decoupler reducing the water temperature at the inlet temperature and so the delta-T on the chiller. As a consequence the chiller control will reduce the speed of the pump, reducing the primary flow rate.

On the opposite, when the flow rate on secondary flow increases also the water temperature at the chiller inlet increases (increasing the delta-T); therefore, the chiller control will increase the water flow rate.

Variable Primary Flow (OP. code 143) OP. incompatibility 172-173

By selecting OP. 143 the chiller can manage the Variable Primary water flow according to the differential pressure measured in a specific point of the plant, selected by the plant designer. The differential pressure transducer is available as option from the factory (OP. code 144). Once installed, the differential pressure transducer must be connected to the unit. As an alternative the unit controller can receive directly the differential pressure value from an external BMS communicating with the standards communication protocols (eg. MODBUS).

The Variable Primary Flow (VPF) configuration is an alternative to the more "traditional" Primary/Secondary (P/S) plant configuration.

An installation must follow all the design criteria for such systems to be defined as Variable Primary Flow.

For this reason, the option 143 should be ordered only if the customer asks for unit capable to manage the speed of the pump in a system designed to operate according to the Variable Primary Flow configuration and not as a general answer to "variable pump speed".

By selecting opt. 143, the chiller can manage the variable primary water flow according to the differential pressure measured in a specific point of the plant, selected by the plant designer.

Daikin Applied Europe is not responsible for the plant configuration and cannot confirm the optimal position of the differential pressure transducer.

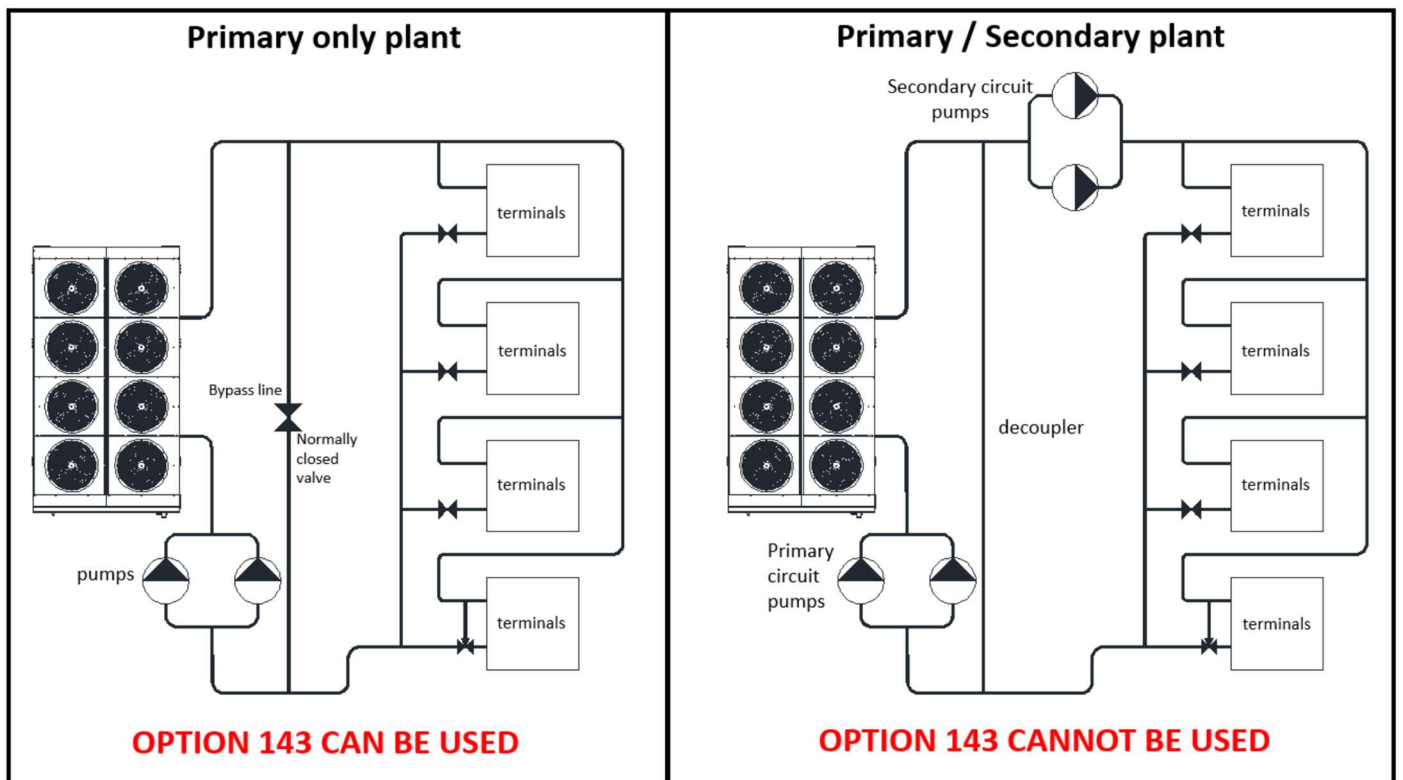
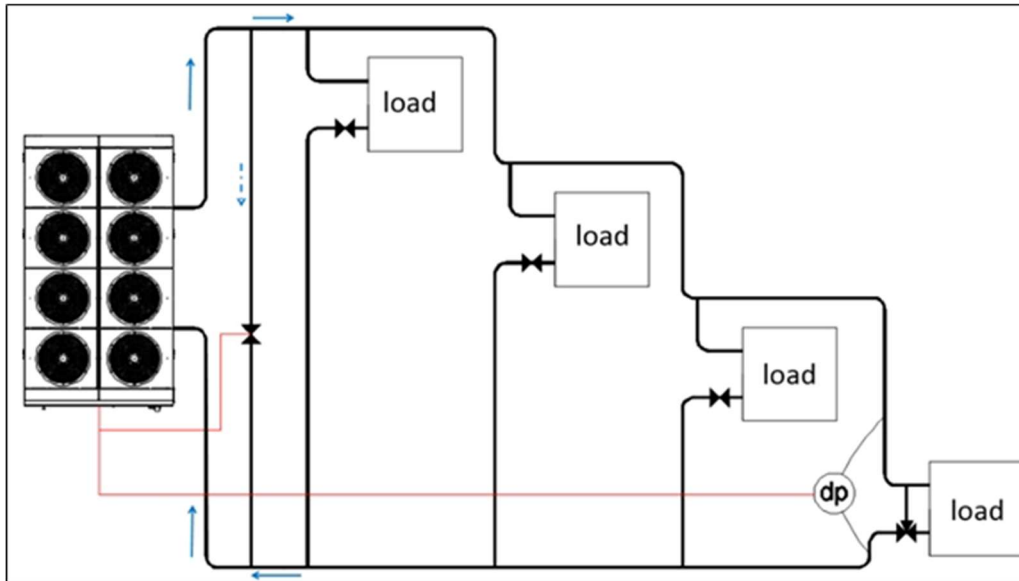

A bypass line (field supply) needs to be installed which guarantees that at all times the minimum water flow of the chiller is supplied (refer to the "Operating limit" chapter for indication on minimum water flow). The bypass valve will be an ON/OFF normally closed valve controlled by the chiller. In case the minimum water flow allowed is not reached, the chiller will open the bypass line restoring the water flow above the minimum value.

In case of multiple units installations in a primary only plant, to control the pump speed iCM is required. Master/Slave function does not support primary only chilled water systems with variable flow operation. For unit installed in Primary/Secondary plants the option Variable Primary Flow is not applicable. In this case a different a different control is required.

For different kind of water flow management iCM must be provided.

To operate in Primary/Secondary plants with variable flow in primary loop the iCM must be provided.

Hydronic options summarizing table

	Fixed speed	Variable speed pump (for "thermostat off" pump speed function or to be controlled with external BMS)	Variable Primary Flow management
ONE CENTRIFUGAL PUMP (LOW LIFT)	Opt 78	Opt 78 + Opt 120e	Opt 78 + Opt 120e + Opt 143
ONE CENTRIFUGAL PUMP (HIGH LIFT)	Opt 79	Opt 79 + Opt 120f	Opt 79 + Opt 120f + Opt 143
TWO CENTRIFUGAL PUMP (LOW LIFT)	Opt 80	Opt 80 + Opt 120g	Opt 80 + Opt 120g + Opt 143
TWO CENTRIFUGAL PUMP (HIGH LIFT)	Opt 81	Opt 81 + Opt 120h	Opt. 81 + Opt 120h + Opt 143

Note: OP.143 can be used only for units installed in a primary only plant to be controlled according to VPF strategy. Master/Slave function does not support primary only chilled water systems with variable flow operation.

Differential Pressure Transducers - shipped loose - (OP. code 144)

Inverter kit for pump Options:

- **INVERTER KIT FOR 1 CENTR PUMP LOW LIFT (opt. code 120e)**
- **INVERTER KIT FOR 1 CENTR PUMP HIGH LIFT (opt. code 120f)**
- **INVERTER KIT FOR 2 CENTR PUMP LOW LIFT (opt. code 120g)**
- **INVERTER KIT FOR 2 CENTR PUMP HIGH LIFT (opt. code 120h)**
- **INV KIT 1 CENTR PUMP LOW LIFT AND TANK (opt. code 120I)**
- **INV KIT 1 CENTR PUMP HIGH LIFT AND TANK (opt. code 120J)**
- **INV KIT 2 CENTR PUMP LOW LIFT AND TANK (opt. code 120K)**
- **INV KIT 2 CENTR PUMP HIGH LIFT AND TANK (opt. code 120L)**

Check the Price List for the Options Inverter kit and Tank

the Inverter kit must be associated with the corresponding hydronic kit. It is standardly not compatible with kit pump + water tank. Contact factory to evaluate feasibility.

For incompatibility refer to the table below:

Option	Description	Incompatibility
120E	INVERTER KIT FOR 1 CENTR PUMP LOW LIFT	03A 120f 120g 120h 120i 120j 120k 120l 78 80 81 134 135 136 137
120F	INVERTER KIT FOR 1 CENTR PUMP HIGH LIFT	03A120e 120g 120h 120i 120j 120k 120l 78 80 81 134 135 136 137
120G	INVERTER KIT FOR 2 CENTR PUMP LOW LIFT	03A 120e 120f 120h 120i 120j 120k 120l 78 79 81 134 135 136 137
120H	INVERTER KIT FOR 2 CENTR PUMP HIGH LIFT	03A120e 120f 120g 120i 120j 120k 120l 78 79 80 134 135 136 137
120I	INV KIT 1 CENTR PUMP LOW LIFT AND TANK	03A 120e 120f 120g 120h 120j 120k 120l 78 79 80 81 135 136 137
120J	INV KIT 1 CENTR PUMP HIGH LIFT AND TANK	03A 120e 120f 120g 120h 120i 120k 120l 78 79 80 81 134 136 137
120K	INV KIT 2 CENTR PUMP LOW LIFT AND TANK	03A 120e 120f 120g 120h 120i 120j 120l 78 79 80 81 134 135 137
120L	INV KIT 2 CENTR PUMP HIGH LIFT AND TANK	03A 120e 120f 120g 120h 120i 120j 120k 78 79 80 81 134 135 136

The inverter kit can be used for the following purposes:

- **Adjusting the water flow rate during unit commissioning.**
- **Control the pump speed via external input from Building Management System (BMS)**

For this application a 0-10V signal for the pump speed must be provided from the plant manager according to the specific control strategy of the plant. The water must be within the minimum and maximum value allowed for the unit (refer to the "Operating limit" chapter). The change in water flow rate must not be exceeded more than 10% of the design water flow rate per minute.

- **Set a "thermostat off" pump speed.** Providing the unit with the inverter kit for the on-board pump is possible to manage two different water flow settings. A setting for water flow during the "Thermostat ON" mode (when the unit is actually providing cooling to the plant), and a set for the "thermostat off" mode (when the plant load is satisfied and the compressors are waiting to start). This feature allows to achieve energy saving on plant operating cost by reducing the speed of the pumps when the unit has reached the set point.

Max Ambient temperature for a proper working of the Inverters is 40°C.

Daikin on site modem with antenna (opt. code 155)

Whenever LAN connection to the unit will not be available, connecting the unit to Daikin on Site will be possible through a dedicated 3G M2M modem that can be ordered from Factory. When ordered, the modem will be installed on the unit before leaving the Factory.

Heating only mode (opt. code 188)

Allowing the unit to operate in heating mode only. Cooling mode operation is not supported.

LOW AMBIENT COMFORT HEATING (opt. code 204) - option incompatibility 205

Allowing the unit to operate in heating mode with high Leaving water temperatures at Low ambient temperatures. A very new control logic have been realized, called Discharge Limit Temperature (DLT); this temp. has to be monitored for each compressor with one additional temperature probe for each compressor mounted on the refr. circuit. On the controller side, an expansion board is installed.

COLLECTIVE HOUSING APPLICATION (opt. code 205) - option incompatibility 204-08.

Allowing the unit to operate in heating mode at classical temp of the Collective housing (25°C CLWT). A very new control logic has been realized that regulates fan rotation speed in order to keep saturated suction temperature close to the envelope limit and preserve capacity loss. Furthermore, because of the low-pressure ratio and higher mass flow rate, it has been realized this new option kit that allow to use a bigger EXV valve.

Installation options – On request

Rubber anti vibration mounts (opt. code 75) - option incompatibility 77.

Shipped loose, rubber mounts are to be positioned under the base frame of the unit during installation. Ideal to reduce the vibrations when the unit is floor mounted.

Spring anti vibration mounts (opt. code 77) - option incompatibility 75.

Shipped loose, spring mounts are to be positioned under the base frame of the unit during installation. Ideal for dampening vibrations for installation on roofs and metallic structures.

External tank without cabinet – 500 L (opt. code 83)

Inertial tank for chilled water storage - *option incompatibility 84-87-88.*

External tank without cabinet – 1000 L (opt. code 84)

Inertial tank for chilled water storage - *option incompatibility 83-87-88.*

External tank with cabinet – 500 L (opt. code 87)

Inertial tank for chilled water storage with cabinet - *option incompatibility 83-84-88.*

External tank with cabinet – 1000 L (opt. code 88)

Inertial tank for chilled water storage with cabinet - *option incompatibility 83-84-87.*

Other options – On request

Container kit (opt. code 71)

Specific solution designed to facilitate loading/unloading of the unit into the container and to reduce risk of damage. - *option incompatibility 112.*

Transport kit (opt. code 112)

Specific solution that offers shocks' absorption during unit transportation. - *option incompatibility 71.*

EWYT~B-SS

MODEL		EWYT085B-SSA1	EWYT105B-SSA1	EWYT135B-SSA1	EWYT175B-SSA1	EWYT205B-SSA2	EWYT215B-SSA1
COOLING PERFORMANCE							
Capacity - Cooling	kW	75	98	120	153	189	193
Capacity control - Type		STEP	STEP	STEP	STEP	STEP	STEP
Capacity control - Minimum capacity	%	50	38	50	38	19	50
Unit power input - Cooling	kW	28	36.6	44.6	57.8	71.3	72.3
EER		2.69	2.68	2.7	2.65	2.66	2.67
SEER		3.9	3.98	3.9	4.01	3.96	3.9
IPLV		4.43	4.4	4.32	4.28	4.33	4.36
CASING							
Colour *		IW	IW	IW	IW	IW	IW
Material *		GPSS	GPSS	GPSS	GPSS	GPSS	GPSS
DIMENSIONS							
Height	mm	1801	1801	1801	1801	1801	1801
Width	mm	1211	1211	1211	1211	1211	1211
Length	mm	2227	2776	3426	3426	4424	4028
WEIGHT							
Unit Weight	kg	764	945	947	1206	1572	1478
Operating Weight	kg	772	953	954	1214	1583	1495
WATER HEAT EXCHANGER							
Type *		PHE	PHE	PHE	PHE	PHE	PHE
Fluid		Water	Water	Water	Water	Water	Water
Fouling Factor	m ² C/W	0	0	0	0	0	0
Water Volume	l	7	7	7	7	11	11
Water temperature in	°C	12	12	12	12	12	12
Water temperature out	°C	7	7	7	7	7	7
Water flow rate	l/s	3.6	4.7	5.8	7.3	9	9.2
Water pressure drop	kPa	14.9	24.1	35.1	54	45	46.4
Insulation material *		Closed Cell	Closed Cell	Closed Cell	Closed Cell	Closed Cell	Closed Cell
AIR HEAT EXCHANGER							
Type *		HFP	HFP	HFP	HFP	HFP	HFP
FAN							
Type *		DPT	DPT	DPT	DPT	DPT	DPT
Drive *		Phase cut	Phase cut	Phase cut	Phase cut	Phase cut	Phase cut
Diameter	mm	450	450	450	450	450	450
Nominal air flow	l/s	6888	10809	14412	13777	17220	17221
Air Temperature	°C	35	35	35	35	35	35
Quantity	No.	4	6	8	8	10	10
Speed	rpm	1360	1360	1360	1360	1360	1360
Motor input	kW	1.8	2.8	3.7	3.7	4.6	4.6
COMPRESSOR							
Type		Scroll	Scroll	Scroll	Scroll	Scroll	Scroll
Oil charge	l	6.5	7.69	8.88	10.7	15.3	12.6
Quantity	No.	2	2	2	2	4	2
SOUND LEVEL**							
Sound Power - Cooling	dB(A)	83.8	87.2	89.1	90.8	89.9	92.2
Sound Pressure level@1m distance - Cooling	dB(A)	66.4	69.4	70.9	72.6	71.2	73.7
REFRIGERANT CIRCUIT							
Refrigerant type		R32	R32	R32	R32	R32	R32
Refrigerant charge	kg	11	19	27	27	35	35
N. of circuits	No.	1	1	1	1	2	1
PIPING CONNECTIONS							
Evaporator water inlet/outlet	mm	88.9	88.9	88.9	88.9	88.9	88.9

MODEL		EWYT235B-SSA2	EWYT255B-SSA2	EWYT300B-SSA2	EWYT340B-SSA2	EWYT390B-SSA2
COOLING PERFORMANCE						
Capacity - Cooling	kW	212	230	270	317	350
Capacity control - Type		STEP	STEP	STEP	STEP	STEP
Capacity control - Minimum capacity	%	17	25	22	19	17
Unit power input - Cooling	kW	78.9	86.5	102	117	132
EER		2.69	2.66	2.65	2.69	2.63
SEER		3.96	3.9	3.99	4.1	3.99
IPLV		4.31	4.35	4.2	4.31	4.2
CASING						
Colour *		IW	IW	IW	IW	IW
Material *		GPSS	GPSS	GPSS	GPSS	GPSS
DIMENSIONS						
Height	mm	1801	1801	2516	2516	2516
Width	mm	1211	1211	2224	2224	2224
Length	mm	5025	5025	3418	3418	4316
WEIGHT						
Unit Weight	kg	1533	1569	2514	2864	3278
Operating Weight	kg	1544	1583	2527	2883	3297
WATER HEAT EXCHANGER						
Type *		PHE	PHE	PHE	PHE	PHE
Fluid		Water	Water	Water	Water	Water
Fouling Factor	m ² °C/W	0	0	0	0	0
Water Volume	l	11	14	14	20	20
Water temperature in	°C	12	12	12	12	12
Water temperature out	°C	7	7	7	7	7
Water flow rate	l/s	10.1	11	12.9	15.1	16.7
Water pressure drop	kPa	55.1	45.1	60.2	49.2	58.8
Insulation material *		Closed Cell	Closed Cell	Closed Cell	Closed Cell	Closed Cell
AIR HEAT EXCHANGER						
Type *		HFP	HFP	HFP	HFP	HFP
FAN						
Type *		DPT	DPT	DPT	DPT	DPT
Drive *		Phase cut	Phase cut	On/Off	On/Off	On/Off
Diameter	mm	450	450	800	800	800
Nominal air flow	l/s	20664	20664	28003	33604	46854
Air Temperature	°C	35	35	35	35	35
Quantity	No.	12	12	5	6	8
Speed	rpm	1360	1360	900	900	900
Motor input	kW	5.5	5.5	8.7	10.4	13.9
COMPRESSOR						
Type		Scroll	Scroll	Scroll	Scroll	Scroll
Oil charge	l	16.5	17.7	19.6	21.4	23.3
Quantity	No.	4	4	4	4	4
SOUND LEVEL**						
Sound Power - Cooling	dB(A)	91.0	91.7	94.0	94.9	95.9
Sound Pressure level@1m distance - Cooling	dB(A)	72.0	72.7	74.5	75.4	75.9
REFRIGERANT CIRCUIT						
Refrigerant type		R32	R32	R32	R32	R32
Refrigerant charge	kg	43	43	27.5	42	71
N. of circuits	No.	2	2	2	2	2
PIPING CONNECTIONS						
Evaporator water inlet/outlet	mm	88.9	88.9	88.9	88.9	88.9

MODEL		EWYT430B-SSA2	EWYT490B-SSA2	EWYT540B-SSA2	EWYT590B-SSA2	EWYT630B-SSA2
COOLING PERFORMANCE						
Capacity - Cooling	kW	375	434	482	531	570
Capacity control - Type		Step	Step	Step	Step	Step
Capacity control - Minimum capacity	%	25	22	19	18	17
Unit power input - Cooling	kW	147	171	192	206	219
EER		2.55	2.54	2.51	2.57	2.6
SEER		4	4.23	4.23	4.17	4.25
IPLV		4.31	4.46	4.52	4.44	4.53
CASING						
Colour *		IW	IW	IW	IW	IW
Material *		GPSS	GPSS	GPSS	GPSS	GPSS
DIMENSIONS						
Height	mm	2516	2516	2516	2516	2516
Width	mm	2224	2224	2224	2224	2224
Length	mm	4316	4316	4316	5211	5211
WEIGHT						
Unit Weight	kg	3324	3483	3685	4089	4264
Operating Weight	kg	3343	3510	3712	4124	4305
WATER HEAT EXCHANGER						
Type *		PHE	PHE	PHE	PHE	PHE
Fluid		Water	Water	Water	Water	Water
Fouling Factor	m ² °C/W	0	0	0	0	0
Water Volume	l	20	27	27	35	41
Water temperature in	°C	12	12	12	12	12
Water temperature out	°C	7	7	7	7	7
Water flow rate	l/s	17.9	20.7	23	25.3	27.2
Water pressure drop	kPa	66.7	58.7	71.2	58.3	66.1
Insulation material *		Closed Cell	Closed Cell	Closed Cell	Closed Cell	Closed Cell
AIR HEAT EXCHANGER						
Type *		HFP	HFP	HFP	HFP	HFP
FAN						
Type *		DPT	DPT	DPT	DPT	DPT
Drive *		On/Off	On/Off	On/Off	On/Off	On/Off
Diameter	mm	800	800	800	800	800
Nominal air flow	l/s	46854	45830	44806	57288	56008
Air Temperature	°C	35	35	35	35	35
Quantity	No.	8	8	8	10	10
Speed	rpm	900	900	900	900	900
Motor input	kW	13.9	13.9	13.9	17.4	17.4
COMPRESSOR						
Type		Scroll	Scroll	Scroll	Scroll	Scroll
Oil charge	l	25.2	29.6	34	35.9	37.8
Quantity	No.	4	5	6	6	6
SOUND LEVEL**						
Sound Power - Cooling	dB(A)	96.3	96.6	96.8	97.5	97.8
Sound Pressure level@1m distance - Cooling	dB(A)	76.3	76.6	76.8	77.1	77.4
REFRIGERANT CIRCUIT						
Refrigerant type		R32	R32	R32	R32	R32
Refrigerant charge	kg	71	71	71	85.5	100
N. of circuits	No.	2	2	2	2	2
PIPING CONNECTIONS						
Evaporator water inlet/outlet	mm	88.9	88.9	88.9	88.9	88.9

EWYT~B-SL

MODEL		EWYT085B-SLA1	EWYT105B-SLA1	EWYT135B-SLA1	EWYT175B-SLA1	EWYT205B-SLA2	EWYT215B-SLA1
COOLING PERFORMANCE							
Capacity - Cooling	kW	75	98	120	153	189	193
Capacity control - Type		STEP	STEP	STEP	STEP	STEP	STEP
Capacity control - Minimum capacity	%	50	38	50	38	19	50
Unit power input - Cooling	kW	28	36.6	44.8	57.9	71.4	72.3
EER		2.69	2.68	2.7	2.65	2.66	2.67
SEER		3.9	3.98	3.9	4.01	3.96	3.9
IPLV		4.43	4.4	4.32	4.28	4.33	4.36
CASING							
Colour *		IW	IW	IW	IW	IW	IW
Material *		GPSS	GPSS	GPSS	GPSS	GPSS	GPSS
DIMENSIONS							
Height	mm	1801	1801	1801	1801	1801	1801
Width	mm	1211	1211	1211	1211	1211	1211
Length	mm	2227	2776	3426	3426	4424	4028
WEIGHT							
Unit Weight	kg	764	945	947	1206	1572	1478
Operating Weight	kg	772	953	954	1214	1583	1495
WATER HEAT EXCHANGER							
Type *		PHE	PHE	PHE	PHE	PHE	PHE
Fluid		Water	Water	Water	Water	Water	Water
Fouling Factor	m ² °C/W	0	0	0	0	0	0
Water Volume	l	7	7	7	7	11	11
Water temperature in	°C	12	12	12	12	12	12
Water temperature out	°C	7	7	7	7	7	7
Water flow rate	l/s	3.6	4.7	5.8	7.3	9	9.2
Water pressure drop	kPa	14.9	24.1	35.1	54	45	46.4
Insulation material *		Closed Cell	Closed Cell	Closed Cell	Closed Cell	Closed Cell	Closed Cell
AIR HEAT EXCHANGER							
Type *		HFP	HFP	HFP	HFP	HFP	HFP
FAN							
Type *		DPT	DPT	DPT	DPT	DPT	DPT
Drive *		Phase cut	Phase cut	Phase cut	Phase cut	Phase cut	Phase cut
Diameter	mm	450	450	450	450	450	450
Nominal air flow	l/s	6888	10809	14412	13777	17220	17221
Air Temperature	°C	35	35	35	35	35	35
Quantity	No.	4	6	8	8	10	10
Speed	rpm	1360	1360	1360	1360	1360	1360
Motor input	kW	1.8	2.7	3.7	3.7	4.6	4.6
COMPRESSOR							
Type		Scroll	Scroll	Scroll	Scroll	Scroll	Scroll
Oil charge	l	6.5	7.69	8.88	10.7	15.3	12.6
Quantity	No.	2	2	2	2	4	2
SOUND LEVEL**							
Sound Power - Cooling	dB(A)	82.7	85.2	86.8	87.8	87.7	89.0
Sound Pressure level@1m distance - Cooling	dB(A)	65.3	67.4	68.6	69.6	69.0	70.5
REFRIGERANT CIRCUIT							
Refrigerant type		R32	R32	R32	R32	R32	R32
Refrigerant charge	kg	11	19	27	27	35	35
N. of circuits	No.	1	1	1	1	2	1
PIPING CONNECTIONS							
Evaporator water inlet/outlet	mm	88.9	88.9	88.9	88.9	88.9	88.9

MODEL		EWYT235B-SLA2	EWYT255B-SLA2	EWYT300B-SLA2	EWYT340B-SLA2	EWYT390B-SLA2
COOLING PERFORMANCE						
Capacity - Cooling	kW	212	230	270	317	350
Capacity control - Type		STEP	STEP	STEP	STEP	STEP
Capacity control - Minimum capacity	%	17	25	22	19	17
Unit power input - Cooling	kW	78.9	86.5	102	117	132
EER		2.69	2.66	2.65	2.69	2.63
SEER		3.96	3.9	3.99	4.1	3.99
IPLV		4.31	4.35	4.2	4.31	4.2
CASING						
Colour *		IW	IW	IW	IW	IW
Material *		GPSS	GPSS	GPSS	GPSS	GPSS
DIMENSIONS						
Height	mm	1801	1801	2516	2516	2516
Width	mm	1211	1211	2224	2224	2224
Length	mm	5025	5025	3418	3418	4316
WEIGHT						
Unit Weight	kg	1533	1569	2627	2978	3390
Operating Weight	kg	1544	1583	2640	2997	3409
WATER HEAT EXCHANGER						
Type *		PHE	PHE	PHE	PHE	PHE
Fluid		Water	Water	Water	Water	Water
Fouling Factor	m ² °C/W	0	0	0	0	0
Water Volume	l	11	14	14	20	20
Water temperature in	°C	12	12	12	12	12
Water temperature out	°C	7	7	7	7	7
Water flow rate	l/s	10.1	11	12.9	15.1	16.7
Water pressure drop	kPa	55.1	45.1	60.2	49.2	58.8
Insulation material *		Closed Cell	Closed Cell	Closed Cell	Closed Cell	Closed Cell
AIR HEAT EXCHANGER						
Type *		HFP	HFP	HFP	HFP	HFP
FAN						
Type *		DPT	DPT	DPT	DPT	DPT
Drive *		Phase cut	Phase cut	On/Off	On/Off	On/Off
Diameter	mm	450	450	800	800	800
Nominal air flow	l/s	20664	20664	28003	33604	46854
Air Temperature	°C	35	35	35	35	35
Quantity	No.	12	12	5	6	8
Speed	rpm	1360	1360	900	900	900
Motor input	kW	5.5	5.5	8.7	10.4	13.9
COMPRESSOR						
Type		Scroll	Scroll	Scroll	Scroll	Scroll
Oil charge	l	16.5	17.7	19.6	21.4	23.3
Quantity	No.	4	4	4	4	4
SOUND LEVEL**						
Sound Power - Cooling	dB(A)	88.6	89.0	90.8	91.6	92.8
Sound Pressure level@1m distance - Cooling	dB(A)	69.6	70.0	71.3	72.1	72.8
REFRIGERANT CIRCUIT						
Refrigerant type		R32	R32	R32	R32	R32
Refrigerant charge	kg	43	43	27.5	42	71
N. of circuits	No.	2	2	2	2	2
PIPING CONNECTIONS						
Evaporator water inlet/outlet	mm	88.9	88.9	88.9	88.9	88.9

MODEL		EWYT430B-SLA2	EWYT490B-SLA2	EWYT540B-SLA2	EWYT590B-SLA2	EWYT630B-SLA2
COOLING PERFORMANCE						
Capacity - Cooling	kW	375	434	482	531	570
Capacity control - Type		Step	Step	Step	Step	Step
Capacity control - Minimum capacity	%	25	22	19	18	17
Unit power input - Cooling	kW	147	171	192	206	219
EER		2.55	2.54	2.51	2.57	2.6
SEER		4	4.23	4.23	4.17	4.25
IPLV		4.31	4.46	4.52	4.44	4.53
CASING						
Colour *		IW	IW	IW	IW	IW
Material *		GPSS	GPSS	GPSS	GPSS	GPSS
DIMENSIONS						
Height	mm	2516	2516	2516	2516	2516
Width	mm	2224	2224	2224	2224	2224
Length	mm	4316	4316	4316	5211	5211
WEIGHT						
Unit Weight	kg	3427	3614	3815	4218	4395
Operating Weight	kg	3446	3641	3842	4253	4436
WATER HEAT EXCHANGER						
Type *		PHE	PHE	PHE	PHE	PHE
Fluid		Water	Water	Water	Water	Water
Fouling Factor	m ² °C/W	0	0	0	0	0
Water Volume	l	20	27	27	35	41
Water temperature in	°C	12	12	12	12	12
Water temperature out	°C	7	7	7	7	7
Water flow rate	l/s	17.9	20.7	23	25.3	27.2
Water pressure drop	kPa	66.7	58.7	71.2	58.3	66.1
Insulation material *		Closed Cell	Closed Cell	Closed Cell	Closed Cell	Closed Cell
AIR HEAT EXCHANGER						
Type *		HFP	HFP	HFP	HFP	HFP
FAN						
Type *		DPT	DPT	DPT	DPT	DPT
Drive *		On/Off	On/Off	On/Off	On/Off	On/Off
Diameter	mm	800	800	800	800	800
Nominal air flow	l/s	46854	45830	44806	57288	56008
Air Temperature	°C	35	35	35	35	35
Quantity	No.	8	8	8	10	10
Speed	rpm	900	900	900	900	900
Motor input	kW	13.9	13.9	13.9	17.4	17.4
COMPRESSOR						
Type		Scroll	Scroll	Scroll	Scroll	Scroll
Oil charge	l	25.2	29.6	34	35.9	37.8
Quantity	No.	4	5	6	6	6
SOUND LEVEL**						
Sound Power - Cooling	dB(A)	92.9	92.9	93	93.9	93.9
Sound Pressure level@1m distance - Cooling	dB(A)	72.9	72.9	73	73.5	73.5
REFRIGERANT CIRCUIT						
Refrigerant type		R32	R32	R32	R32	R32
Refrigerant charge	kg	71	71	71	85.5	100
N. of circuits	No.	2	2	2	2	2
PIPING CONNECTIONS						
Evaporator water inlet/outlet	mm	88.9	88.9	88.9	88.9	88.9

EWYT~B-SR

MODEL		EWYT085B-SRA1	EWYT105B-SRA1	EWYT135B-SRA1	EWYT175B-SRA1	EWYT205B-SRA2	EWYT215B-SRA1
COOLING PERFORMANCE							
Capacity - Cooling	kW	74	96	119	150	186	189
Capacity control - Type		STEP	STEP	STEP	STEP	STEP	STEP
Capacity control - Minimum capacity	%	50	38	50	38	19	50
Unit power input - Cooling	kW	28.7	37.4	45.5	59.5	73.2	74.3
EER		2.56	2.58	2.61	2.53	2.54	2.55
SEER		3.82	3.93	3.87	3.96	3.92	3.82
IPLV		4.36	4.24	4.3	4.38	4.29	4.29
CASING							
Colour *		IW	IW	IW	IW	IW	IW
Material *		GPSS	GPSS	GPSS	GPSS	GPSS	GPSS
DIMENSIONS							
Height	mm	1801	1801	1801	1801	1801	1801
Width	mm	1211	1211	1211	1211	1211	1211
Length	mm	2227	2776	3426	3426	4424	4028
WEIGHT							
Unit Weight	kg	764	945	947	1206	1572	1478
Operating Weight	kg	772	953	954	1214	1583	1495
WATER HEAT EXCHANGER							
Type *		PHE	PHE	PHE	PHE	PHE	PHE
Fluid		Water	Water	Water	Water	Water	Water
Fouling Factor	m ² °C/W	0	0	0	0	0	0
Water Volume	l	7	7	7	7	11	11
Water temperature in	°C	12	12	12	12	12	12
Water temperature out	°C	7	7	7	7	7	7
Water flow rate	l/s	3.5	4.6	5.7	7.2	8.9	9
Water pressure drop	kPa	14.4	23.4	34.2	52.2	43.5	44.8
Insulation material *		Closed Cell	Closed Cell	Closed Cell	Closed Cell	Closed Cell	Closed Cell
AIR HEAT EXCHANGER							
Type *		HFP	HFP	HFP	HFP	HFP	HFP
FAN							
Type *		DPT	DPT	DPT	DPT	DPT	DPT
Drive *		Phase cut	Phase cut	Phase cut	Phase cut	Phase cut	Phase cut
Diameter	mm	450	450	450	450	450	450
Nominal air flow	l/s	6026	9483	12644	12052	15064	15065
Air Temperature	°C	35	35	35	35	35	35
Quantity	No.	4	6	8	8	10	10
Speed	rpm	1200	1200	1200	1200	1200	1200
Motor input	kW	1.7	2.5	3.4	3.4	4.2	4.2
COMPRESSOR							
Type		Scroll	Scroll	Scroll	Scroll	Scroll	Scroll
Oil charge	l	6.5	7.69	8.88	10.7	15.3	12.6
Quantity	No.	2	2	2	2	4	2
SOUND LEVEL**							
Sound Power - Cooling	dB(A)	77.8	81.6	83.6	85.4	84.4	86.9
Sound Pressure level@1m distance - Cooling	dB(A)	60.4	63.8	65.4	67.2	65.7	68.4
REFRIGERANT CIRCUIT							
Refrigerant type		R32	R32	R32	R32	R32	R32
Refrigerant charge	kg	11	19	27	27	35	35
N. of circuits	No.	1	1	1	1	2	1
PIPING CONNECTIONS							
Evaporator water inlet/outlet	mm	88.9	88.9	88.9	88.9	88.9	88.9

MODEL		EWYT235B-SRA2	EWYT255B-SRA2	EWYT300B-SRA2	EWYT340B-SRA2	EWYT390B-SRA2
COOLING PERFORMANCE						
Capacity - Cooling	kW	209	226	265	311	344
Capacity control - Type		STEP	STEP	STEP	STEP	STEP
Capacity control - Minimum capacity	%	17	25	22	19	17
Unit power input - Cooling	kW	80.7	88.8	102	117	131
EER		2.59	2.55	2.59	2.64	2.61
SEER		3.83	3.84	4.18	4.37	4.21
IPLV		4.28	4.26	4.29	4.69	4.58
CASING						
Colour *		IW	IW	IW	IW	IW
Material *		GPSS	GPSS	GPSS	GPSS	GPSS
DIMENSIONS						
Height	mm	1801	1801	2516	2516	2516
Width	mm	1211	1211	2224	2224	2224
Length	mm	5025	5025	3418	3418	4316
WEIGHT						
Unit Weight	kg	1533	1569	2627	2978	3390
Operating Weight	kg	1544	1583	2640	2997	3409
WATER HEAT EXCHANGER						
Type *		PHE	PHE	PHE	PHE	PHE
Fluid		Water	Water	Water	Water	Water
Fouling Factor	m ² °C/W	0	0	0	0	0
Water Volume	l	11	14	14	20	20
Water temperature in	°C	12	12	12	12	12
Water temperature out	°C	7	7	7	7	7
Water flow rate	l/s	10	10.8	12.7	14.8	16.4
Water pressure drop	kPa	53.5	43.6	58.1	47.6	57
Insulation material *		Closed Cell	Closed Cell	Closed Cell	Closed Cell	Closed Cell
AIR HEAT EXCHANGER						
Type *		HFP	HFP	HFP	HFP	HFP
FAN						
Type *		DPT	DPT	DPT	DPT	DPT
Drive *		Phase cut	Phase cut	VFD	VFD	VFD
Diameter	mm	450	450	800	800	800
Nominal air flow	l/s	18078	18078	23608	28330	39446
Air Temperature	°C	35	35	35	35	35
Quantity	No.	12	12	5	6	8
Speed	rpm	1200	1200	780	780	780
Motor input	kW	5	5	5.5	6.6	8.7
COMPRESSOR						
Type		Scroll	Scroll	Scroll	Scroll	Scroll
Oil charge	l	16.5	17.7	19.6	21.4	23.3
Quantity	No.	4	4	4	4	4
SOUND LEVEL**						
Sound Power - Cooling	dB(A)	85.5	86.3	87.2	88.0	89.2
Sound Pressure level@1m distance - Cooling	dB(A)	66.5	67.3	67.7	68.5	69.2
REFRIGERANT CIRCUIT						
Refrigerant type		R32	R32	R32	R32	R32
Refrigerant charge	kg	43	43	27.5	42	71
N. of circuits	No.	2	2	2	2	2
PIPING CONNECTIONS						
Evaporator water inlet/outlet	mm	88.9	88.9	88.9	88.9	88.9

MODEL		EWYT430B-SRA2	EWYT490B-SRA2	EWYT540B-SRA2	EWYT590B-SRA2	EWYT630B-SRA2
COOLING PERFORMANCE						
Capacity - Cooling	kW	368	424	470	519	557
Capacity control - Type		Step	Step	Step	Step	Step
Capacity control - Minimum capacity	%	25	22	19	18	17
Unit power input - Cooling	kW	147	172	195	207	221
EER		2.5	2.46	2.41	2.5	2.51
SEER		4.19	4.49	4.49	4.46	4.52
IPLV		4.61	4.78	4.89	4.82	4.91
CASING						
Colour *		IW	IW	IW	IW	IW
Material *		GPSS	GPSS	GPSS	GPSS	GPSS
DIMENSIONS						
Height	mm	2516	2516	2516	2516	2516
Width	mm	2224	2224	2224	2224	2224
Length	mm	4316	4316	4316	5211	5211
WEIGHT						
Unit Weight	kg	3427	3614	3815	4218	4395
Operating Weight	kg	3446	3641	3842	4253	4436
WATER HEAT EXCHANGER						
Type *		PHE	PHE	PHE	PHE	PHE
Fluid		Water	Water	Water	Water	Water
Fouling Factor	m ² °C/W	0	0	0	0	0
Water Volume	l	20	27	27	35	41
Water temperature in	°C	12	12	12	12	12
Water temperature out	°C	7	7	7	7	7
Water flow rate	l/s	17.5	20.2	22.4	24.8	26.6
Water pressure drop	kPa	64.4	56.3	67.8	56	63.4
Insulation material *		Closed Cell	Closed Cell	Closed Cell	Closed Cell	Closed Cell
AIR HEAT EXCHANGER						
Type *		HFP	HFP	HFP	HFP	HFP
FAN						
Type *		DPT	DPT	DPT	DPT	DPT
Drive *		VFD	VFD	VFD	VFD	VFD
Diameter	mm	800	800	800	800	800
Nominal air flow	l/s	39446	38610	37774	48262	47216
Air Temperature	°C	35	35	35	35	35
Quantity	No.	8	8	8	10	10
Speed	rpm	780	780	780	780	780
Motor input	kW	9	9	9	11.3	11.3
COMPRESSOR						
Type		Scroll	Scroll	Scroll	Scroll	Scroll
Oil charge	l	25.2	29.6	34	35.9	37.8
Quantity	No.	4	5	6	6	6
SOUND LEVEL**						
Sound Power - Cooling	dB(A)	89.3	89.4	89.5	90.4	90.5
Sound Pressure level@1m distance - Cooling	dB(A)	69.3	69.4	69.5	70	70.1
REFRIGERANT CIRCUIT						
Refrigerant type		R32	R32	R32	R32	R32
Refrigerant charge	kg	71	71	71	85.5	100
N. of circuits	No.	2	2	2	2	2
PIPING CONNECTIONS						
Evaporator water inlet/outlet	mm	88.9	88.9	88.9	88.9	88.9

EWYT~B-XS

MODEL		EWYT085B-XSA1	EWYT115B-XSA1	EWYT135B-XSA1	EWYT175B-XSA1	EWYT215B-XSA1	EWYT215B-XSA2
COOLING PERFORMANCE							
Capacity - Cooling	kW	80	104	126	166	206	206
Capacity control - Type		STEP	STEP	STEP	STEP	STEP	STEP
Capacity control - Minimum capacity	%	50	38	50	38	50	19
Unit power input - Cooling	kW	26.3	35.1	42.1	56.6	71.8	68
EER		3.03	2.95	2.99	2.93	2.86	3.03
SEER		4.24	4.38	4.24	4.45	4.21	4.41
IPLV		4.75	4.69	4.69	4.69	4.72	4.87
CASING							
Colour *		IW	IW	IW	IW	IW	IW
Material *		GPSS	GPSS	GPSS	GPSS	GPSS	GPSS
DIMENSIONS							
Height	mm	1801	1801	1801	1801	1801	1801
Width	mm	1211	1211	1211	1211	1211	1211
Length	mm	2776	3426	3426	4024	4628	5625
WEIGHT							
Unit Weight	kg	927	930	996	1367	1522	2099
Operating Weight	kg	938	941	1007	1393	1564	2135
WATER HEAT EXCHANGER							
Type *		PHE	PHE	PHE	PHE	PHE	PHE
Fluid		Water	Water	Water	Water	Water	Water
Fouling Factor	m ² °C/W	0	0	0	0	0	0
Water Volume	l	11	11	11	16	16	35
Water temperature in	°C	12	12	12	12	12	12
Water temperature out	°C	7	7	7	7	7	7
Water flow rate	l/s	3.8	5	6	7.9	9.8	9.8
Water pressure drop	kPa	9.49	15.2	21.5	20.1	29.6	12
Insulation material *		Closed Cell	Closed Cell	Closed Cell	Closed Cell	Closed Cell	Closed Cell
AIR HEAT EXCHANGER							
Type *		HFP	HFP	HFP	HFP	HFP	HFP
FAN							
Type *		DPT	DPT	DPT	DPT	DPT	DPT
Drive *		Phase cut	Phase cut	Phase cut	Phase cut	Phase cut	Phase cut
Diameter	mm	450	450	450	450	450	450
Nominal air flow	l/s	9039	12644	12052	15065	18078	21090
Air Temperature	°C	35	35	35	35	35	35
Quantity	No.	6	8	8	10	12	14
Speed	rpm	1200	1200	1200	1200	1200	1200
Motor input	kW	2.5	3.4	3.4	4.2	5	5.9
COMPRESSOR							
Type		Scroll	Scroll	Scroll	Scroll	Scroll	Scroll
Oil charge	l	6.5	7.69	8.88	10.7	12.6	15.3
Quantity	No.	2	2	2	2	2	4
SOUND LEVEL**							
Sound Power - Cooling	dB(A)	81.2	85.6	87.6	89.9	91.4	88.5
Sound Pressure level@1m distance - Cooling	dB(A)	63.4	67.4	69.4	71.4	72.6	69.2
REFRIGERANT CIRCUIT							
Refrigerant type		R32	R32	R32	R32	R32	R32
Refrigerant charge	kg	17	29.4	29.8	34.5	44	50
N. of circuits	No.	1	1	1	1	1	2
PIPING CONNECTIONS							
Evaporator water inlet/outlet	mm	88.9	88.9	88.9	88.9	88.9	88.9

MODEL		EWYT235B-XSA2	EWYT265B-XSA2	EWYT310B-XSA2	EWYT350B-XSA2
COOLING PERFORMANCE					
Capacity - Cooling	kW	229	250	288	328
Capacity control - Type		STEP	STEP	STEP	STEP
Capacity control - Minimum capacity	%	17	25	22	19
Unit power input - Cooling	kW	74.9	83.4	95.9	109
EER		3.06	3	3.06	3.05
SEER		4.4	4.13	4.57	4.67
IPLV		4.87	4.64	4.94	4.96
CASING					
Colour *		IW	IW	IW	IW
Material *		GPSS	GPSS	GPSS	GPSS
DIMENSIONS					
Height	mm	1801	1801	2516	2516
Width	mm	1211	1211	2224	2224
Length	mm	6223	6223	4316	4316
WEIGHT					
Unit Weight	kg	1766	1797	3073	3254
Operating Weight	kg	1796	1827	3103	3289
WATER HEAT EXCHANGER					
Type *		PHE	PHE	PHE	PHE
Fluid		Water	Water	Water	Water
Fouling Factor	m ² C/W	0	0	0	0
Water Volume	l	35	35	35	35
Water temperature in	°C	12	12	12	12
Water temperature out	°C	7	7	7	7
Water flow rate	l/s	10.9	11.9	14	16
Water pressure drop	kPa	14.6	17.1	22.8	28.9
Insulation material *		Closed Cell	Closed Cell	Closed Cell	Closed Cell
AIR HEAT EXCHANGER					
Type *		HFP	HFP	HFP	HFP
FAN					
Type *		DPT	DPT	DPT	DPT
Drive *		Phase cut	Phase cut	On/Off	On/Off
Diameter	mm	450	450	800	800
Nominal air flow	l/s	24104	24104	29593	33820
Air Temperature	°C	35	35	35	35
Quantity	No.	16	16	7	8
Speed	rpm	1200	1200	700	700
Motor input	kW	6.7	6.7	6	6.9
COMPRESSOR					
Type		Scroll	Scroll	Scroll	Scroll
Oil charge	l	16.5	17.7	19.6	21.4
Quantity	No.	4	4	4	4
SOUND LEVEL**					
Sound Power - Cooling	dB(A)	89.7	90.6	92.4	93.4
Sound Pressure level@1m distance - Cooling	dB(A)	70.2	71.1	72.4	73.4
REFRIGERANT CIRCUIT					
Refrigerant type		R32	R32	R32	R32
Refrigerant charge	kg	50	55	70	70
N. of circuits	No.	2	2	2	2
PIPING CONNECTIONS					
Evaporator water inlet/outlet	mm	88.9	88.9	88.9	88.9

TECHNICAL SPECIFICATION

MODEL		EWYT400B-XSA2	EWYT440B-XSA2	EWYT500B-XSA2	EWYT560B-XSA2	EWYT600B-XSA2	EWYT630B-XSA2	EWYT650B-XSA2
COOLING PERFORMANCE								
Capacity - Cooling	kW	370	406	467	519	560	597	610
Capacity control - Type		Step	Step	Step	Step	Step	Step	Step
Capacity control - Minimum capacity	%	17	25	22	19	18	17	17
Unit power input - Cooling	kW	122	134	158	177	193	204	207
EER		3.02	3.01	2.95	2.93	2.9	2.92	2.95
SEER		4.54	4.57	4.72	4.71	4.70	4.69	4.4
IPLV		4.96	5	5.1	5.08	5.05	5.05	4.66
CASING								
Colour *		IW	IW	IW	IW	IW	IW	IW
Material *		GPSS	GPSS	GPSS	GPSS	GPSS	GPSS	GPSS
DIMENSIONS								
Height	mm	2516	2527	2527	2527	2527	2527	2527
Width	mm	2224	2224	2224	2224	2224	2224	2224
Length	mm	5211	5211	6112	6112	7010	7010	7010
WEIGHT								
Unit Weight	kg	3613	3933	4208	4457	4791	4957	4957
Operating Weight	kg	3648	3945	4270	4527	4861	5027	5027
WATER HEAT EXCHANGER								
Type *		PHE	PHE	PHE	PHE	PHE	PHE	PHE
Fluid		Water	Water	Water	Water	Water	Water	Water
Fouling Factor	m ² °C/W	0	0	0	0	0	0	0
Water Volume	l	35	62	62	70	70	70	70
Water temperature in	°C	12	12	12	12	12	12	12
Water temperature out	°C	7	7	7	7	7	7	7
Water flow rate	l/s	17.7	19.4	22.3	24.7	26.7	28.5	29.1
Water pressure drop	kPa	34.7	23.6	30.4	33.6	38.6	43.2	45
Insulation material *		Closed Cell	Closed Cell	Closed Cell	Closed Cell	Closed Cell	Closed Cell	Closed Cell
AIR HEAT EXCHANGER								
Type *		HFP	HFP	HFP	HFP	HFP	HFP	HFP
FAN								
Type *		DPT	DPT	DPT	DPT	DPT	DPT	DPT
Drive *		On/Off	On/Off	On/Off	On/Off	On/Off	On/Off	On/Off
Diameter	mm	800	800	800	800	800	800	800
Nominal air flow	l/s	43351	42276	52021	50730	60692	59186	78410
Air Temperature	°C	35	35	35	35	35	35	35
Quantity	No.	10	10	12	12	14	14	14
Speed	rpm	700	700	700	700	700	700	900
Motor input	kW	8.6	8.6	10.3	10.3	12.1	12.1	24.4
COMPRESSOR								
Type		Scroll	Scroll	Scroll	Scroll	Scroll	Scroll	Scroll
Oil charge	l	23.3	25.2	29.6	34	35.9	37.8	37.8
Quantity	No.	4	4	5	6	6	6	6
SOUND LEVEL**								
Sound Power - Cooling	dB(A)	94.2	94.8	95.3	95.6	96.1	96.5	98.4
Sound Pressure level@1m distance - Cooling	dB(A)	73.8	74.4	74.5	74.8	75.0	75.4	77.3
REFRIGERANT CIRCUIT								
Refrigerant type		R32	R32	R32	R32	R32	R32	R32
Refrigerant charge	kg	85	100	114.5	129	143.5	158	158
N. of circuits	No.	2	2	2	2	2	2	2
PIPING CONNECTIONS								
Evaporator water inlet/outlet	mm	88.9	88.9	88.9	88.9	88.9	88.9	88.9

EWYT~B-XL

MODEL		EWYT085B-XLA1	EWYT115B-XLA1	EWYT135B-XLA1	EWYT175B-XLA1	EWYT215B-XLA1
COOLING PERFORMANCE						
Capacity - Cooling	kW	80	104	126	166	206
Capacity control - Type		STEP	STEP	STEP	STEP	STEP
Capacity control - Minimum capacity	%	50	38	50	38	50
Unit power input - Cooling	kW	26.3	35.1	42.1	56.6	71.8
EER		3.03	2.95	2.99	2.93	2.86
SEER		4.24	4.38	4.24	4.45	4.21
IPLV		4.75	4.69	4.69	4.69	4.72
CASING						
Colour *		IW	IW	IW	IW	IW
Material *		GPSS	GPSS	GPSS	GPSS	GPSS
DIMENSIONS						
Height	mm	1801	1801	1801	1801	1801
Width	mm	1211	1211	1211	1211	1211
Length	mm	2776	3426	3426	4024	4628
WEIGHT						
Unit Weight	kg	927	930	996	1367	1522
Operating Weight	kg	938	941	1007	1393	1564
WATER HEAT EXCHANGER						
Type *		PHE	PHE	PHE	PHE	PHE
Fluid		Water	Water	Water	Water	Water
Fouling Factor	m ² °C/W	0	0	0	0	0
Water Volume	l	11	11	11	16	16
Water temperature in	°C	12	12	12	12	12
Water temperature out	°C	7	7	7	7	7
Water flow rate	l/s	3.8	5	6	7.9	9.8
Water pressure drop	kPa	9.49	15.2	21.5	20.1	29.6
Insulation material *		Closed Cell	Closed Cell	Closed Cell	Closed Cell	Closed Cell
AIR HEAT EXCHANGER						
Type *		HFP	HFP	HFP	HFP	HFP
FAN						
Type *		DPT	DPT	DPT	DPT	DPT
Drive *		VFD	VFD	VFD	VFD	VFD
Diameter	mm	450	450	450	450	450
Nominal air flow	l/s	9039	12644	12052	15065	18078
Air Temperature	°C	35	35	35	35	35
Quantity	No.	6	8	8	10	12
Speed	rpm	1200	1200	1200	1200	1200
Motor input	kW	2.5	3.4	3.4	4.2	5
COMPRESSOR						
Type		Scroll	Scroll	Scroll	Scroll	Scroll
Oil charge	l	6.5	7.69	8.88	10.7	12.6
Quantity	No.	2	2	2	2	2
SOUND LEVEL**						
Sound Power - Cooling	dB(A)	79.5	82.6	84.1	86.2	87.5
Sound Pressure level@1m distance - Cooling	dB(A)	61.2	63.9	65.4	67.2	68.2
REFRIGERANT CIRCUIT						
Refrigerant type		R32	R32	R32	R32	R32
Refrigerant charge	kg	17	29.4	29.8	34.5	44
N. of circuits	No.	1	1	1	1	1
PIPING CONNECTIONS						
Evaporator water inlet/outlet	mm	88.9	88.9	88.9	88.9	88.9

MODEL		EWYT215B-XLA2	EWYT235B-XLA2	EWYT265B-XLA2	EWYT310B-XLA2	EWYT350B-XLA2
COOLING PERFORMANCE						
Capacity - Cooling	kW	206	229	250	288	328
Capacity control - Type		STEP	STEP	STEP	STEP	STEP
Capacity control - Minimum capacity	%	19	17	25	22	19
Unit power input - Cooling	kW	68	74.9	83.4	93.9	107
EER		3.03	3.06	3	3.06	3.05
SEER		4.41	4.4	4.13	4.57	4.67
IPLV		4.87	4.87	4.64	4.94	4.96
CASING						
Colour *		IW	IW	IW	IW	IW
Material *		GPSS	GPSS	GPSS	GPSS	GPSS
DIMENSIONS						
Height	mm	1801	1801	1801	2516	2516
Width	mm	1211	1211	1211	2224	2224
Length	mm	5625	6223	6223	4316	4316
WEIGHT						
Unit Weight	kg	2099	1766	1797	3181	3367
Operating Weight	kg	2135	1796	1827	3216	3402
WATER HEAT EXCHANGER						
Type *		PHE	PHE	PHE	PHE	PHE
Fluid		Water	Water	Water	Water	Water
Fouling Factor	m ² °C/W	0	0	0	0	0
Water Volume	l	35	35	35	35	35
Water temperature in	°C	12	12	12	12	12
Water temperature out	°C	7	7	7	7	7
Water flow rate	l/s	9.8	10.9	11.9	13.7	15.7
Water pressure drop	kPa	12	14.6	17.1	22	27.9
Insulation material *		Closed Cell	Closed Cell	Closed Cell	Closed Cell	Closed Cell
AIR HEAT EXCHANGER						
Type *		HFP	HFP	HFP	HFP	HFP
FAN						
Type *		DPT	DPT	DPT	DPT	DPT
Drive *		VFD	VFD	VFD	On/Off	On/Off
Diameter	mm	450	450	450	800	800
Nominal air flow	l/s	21090	24104	24104	29593	33820
Air Temperature	°C	35	35	35	35	35
Quantity	No.	14	16	16	7	8
Speed	rpm	1200	1200	1200	700	700
Motor input	kW	5.9	6.7	6.7	6	6.9
COMPRESSOR						
Type		Scroll	Scroll	Scroll	Scroll	Scroll
Oil charge	l	15.3	16.5	17.7	19.6	21.4
Quantity	No.	4	4	4	4	4
SOUND LEVEL**						
Sound Power - Cooling	dB(A)	85.4	86.4	87.1	86.4	87.1
Sound Pressure level@1m distance - Cooling	dB(A)	65.6	66.4	67.1	66.4	67.1
REFRIGERANT CIRCUIT						
Refrigerant type		R32	R32	R32	R32	R32
Refrigerant charge	kg	50	50	55	70	70
N. of circuits	No.	2	2	2	2	2
PIPING CONNECTIONS						
Evaporator water inlet/outlet	mm	88.9	88.9	88.9	88.9	88.9

TECHNICAL SPECIFICATION

MODEL		EWYT400B-XLA2	EWYT440B-XLA2	EWYT500B-XLA2	EWYT560B-XLA2	EWYT600B-XLA2	EWYT630B-XLA2	EWYT650B-XLA2
COOLING PERFORMANCE								
Capacity - Cooling	kW	370	406	467	519	560	597	610
Capacity control - Type		Step	Step	Step	Step	Step	Step	Step
Capacity control - Minimum capacity	%	17	25	22	19	18	17	17
Unit power input - Cooling	kW	122	134	158	177	193	204	207
EER		3.02	3.01	2.95	2.93	2.9	2.92	2.95
SEER		4.54	4.57	4.72	4.71	4.70	4.69	4.4
IPLV		4.96	5	5.1	5.08	5.05	5.05	4.66
CASING								
Colour *		IW	IW	IW	IW	IW	IW	IW
Material *		GPSS	GPSS	GPSS	GPSS	GPSS	GPSS	GPSS
DIMENSIONS								
Height	mm	2516	2527	2527	2527	2527	2527	2527
Width	mm	2224	2224	2224	2224	2224	2224	2224
Length	mm	5211	5211	6112	6112	7010	7010	7010
WEIGHT								
Unit Weight	kg	3716	4035	4337	4586	4922	5089	5089
Operating Weight	kg	3751	4097	4399	4656	4992	5159	5159
WATER HEAT EXCHANGER								
Type *		PHE	PHE	PHE	PHE	PHE	PHE	PHE
Fluid		Water	Water	Water	Water	Water	Water	Water
Fouling Factor	m ² °C/W	0	0	0	0	0	0	0
Water Volume	l	35	62	62	70	70	70	70
Water temperature in	°C	12	12	12	12	12	12	12
Water temperature out	°C	7	7	7	7	7	7	7
Water flow rate	l/s	17.7	19.4	22.3	24.7	26.7	28.5	29.1
Water pressure drop	kPa	34.7	23.6	30.4	33.6	38.6	43.2	45
Insulation material *		Closed Cell	Closed Cell	Closed Cell	Closed Cell	Closed Cell	Closed Cell	Closed Cell
AIR HEAT EXCHANGER								
Type *		HFP	HFP	HFP	HFP	HFP	HFP	HFP
FAN								
Type *		DPT	DPT	DPT	DPT	DPT	DPT	DPT
Drive *		On/Off	On/Off	On/Off	On/Off	On/Off	On/Off	On/Off
Diameter	mm	800	800	800	800	800	800	800
Nominal air flow	l/s	43351	42276	52021	50730	60692	59186	78410
Air Temperature	°C	35	35	35	35	35	35	35
Quantity	No.	10	10	12	12	14	14	14
Speed	rpm	700	700	700	700	700	700	900
Motor input	kW	8.6	8.6	10.3	10.3	12.1	12.1	24.4
COMPRESSOR								
Type		Scroll	Scroll	Scroll	Scroll	Scroll	Scroll	Scroll
Oil charge	l	23.3	25.2	29.6	34	35.9	37.8	37.8
Quantity	No.	4	4	5	6	6	6	6
SOUND LEVEL**								
Sound Power - Cooling	dB(A)	88.0	88.2	88.9	89.0	89.6	89.7	95.3
Sound Pressure level@1m distance - Cooling	dB(A)	67.6	67.8	68.1	68.2	68.5	68.6	74.2
REFRIGERANT CIRCUIT								
Refrigerant type		R32	R32	R32	R32	R32	R32	R32
Refrigerant charge	kg	85	100	114.5	129	143.5	158	158
N. of circuits	No.	2	2	2	2	2	2	2
PIPING CONNECTIONS								
Evaporator water inlet/outlet	mm	88.9	88.9	88.9	88.9	88.9	88.9	88.9

EWYT~B-XR

MODEL		EWYT0855B-XRA1	EWYT115B-XRA1	EWYT135B-XRA1	EWYT175B-XRA1	EWYT215B-XRA1	EWYT215B-XRA2
COOLING PERFORMANCE							
Capacity - Cooling	kW	79	103	124	164	203	204
Capacity control - Type		STEP	STEP	STEP	STEP	STEP	STEP
Capacity control - Minimum capacity	%	50	38	50	38	50	19
Unit power input - Cooling	kW	26.6	35.4	42.6	57.4	72.9	68.8
EER		2.98	2.9	2.92	2.86	2.79	2.97
SEER		4.21	4.37	4.21	4.41	4.16	4.42
IPLV		4.73	4.73	4.67	4.65	4.67	4.86
CASING							
Colour *		IW	IW	IW	IW	IW	IW
Material *		GPSS	GPSS	GPSS	GPSS	GPSS	GPSS
DIMENSIONS							
Height	mm	1801	1801	1801	1801	1801	1801
Width	mm	1211	1211	1211	1211	1211	1211
Length	mm	2776	3426	3426	4024	4628	5625
WEIGHT							
Unit Weight	kg	927	930	996	1367	1522	2099
Operating Weight	kg	938	941	1007	1393	1564	2135
WATER HEAT EXCHANGER							
Type *		PHE	PHE	PHE	PHE	PHE	PHE
Fluid		Water	Water	Water	Water	Water	Water
Fouling Factor	m ² °C/W	0	0	0	0	0	0
Water Volume	l	11	11	11	16	16	35
Water temperature in	°C	12	12	12	12	12	12
Water temperature out	°C	7	7	7	7	7	7
Water flow rate	l/s	3.8	4.9	5.9	7.8	9.7	9.7
Water pressure drop	kPa	9.33	14.9	21.1	19.6	28.9	11.8
Insulation material *		Closed Cell	Closed Cell	Closed Cell	Closed Cell	Closed Cell	Closed Cell
AIR HEAT EXCHANGER							
Type *		HFP	HFP	HFP	HFP	HFP	HFP
FAN							
Type *		DPT	DPT	DPT	DPT	DPT	DPT
Drive *		Phase cut	Phase cut	Phase cut	Phase cut	Phase cut	Phase cut
Diameter	mm	450	450	450	450	450	450
Nominal air flow	l/s	8298	11630	11064	13830	16596	19362
Air Temperature	°C	35	35	35	35	35	35
Quantity	No.	6	8	8	10	12	14
Speed	rpm	1108	1108	1108	1108	1108	1108
Motor input	kW	2.4	3.2	3.2	4	4.7	5.5
COMPRESSOR							
Type		Scroll	Scroll	Scroll	Scroll	Scroll	Scroll
Oil charge	l	6.5	7.69	8.88	10.7	12.6	15.3
Quantity	No.	2	2	2	2	2	4
SOUND LEVEL**							
Sound Power - Cooling	dB(A)	77.1	81.0	82.9	85.1	86.5	83.9
Sound Pressure level@1m distance - Cooling	dB(A)	59.3	62.8	64.7	66.6	67.7	64.6
REFRIGERANT CIRCUIT							
Refrigerant type		R32	R32	R32	R32	R32	R32
Refrigerant charge	kg	17	29.4	29.8	34.5	44	50
N. of circuits	No.	1	1	1	1	1	2
PIPING CONNECTIONS							
Evaporator water inlet/outlet	mm	88.9	88.9	88.9	88.9	88.9	88.9

MODEL		EWYT235B-XRA2	EWYT265B-XRA2	EWYT310B-XRA2	EWYT350B-XRA2
COOLING PERFORMANCE					
Capacity - Cooling	kW	227	247	282	321
Capacity control - Type		STEP	STEP	STEP	STEP
Capacity control - Minimum capacity	%	17	25	22	19
Unit power input - Cooling	kW	75.7	84.4	97.2	111
EER		3	2.93	2.96	2.95
SEER		4.43	4.13	4.74	4.8
IPLV		4.82	4.62	4.92	5.12
CASING					
Colour *		IW	IW	IW	IW
Material *		GPSS	GPSS	GPSS	GPSS
DIMENSIONS					
Height	mm	1801	1801	2516	2516
Width	mm	1211	1211	2224	2224
Length	mm	6223	6223	4316	4316
WEIGHT					
Unit Weight	kg	1766	1797	3181	3367
Operating Weight	kg	1796	1827	3216	3402
WATER HEAT EXCHANGER					
Type *		PHE	PHE	PHE	PHE
Fluid		Water	Water	Water	Water
Fouling Factor	m ² °C/W	0	0	0	0
Water Volume	l	35	35	35	35
Water temperature in	°C	12	12	12	12
Water temperature out	°C	7	7	7	7
Water flow rate	l/s	10.8	11.8	13.7	15.7
Water pressure drop	kPa	14.3	16.8	22	27.9
Insulation material *		Closed Cell	Closed Cell	Closed Cell	Closed Cell
AIR HEAT EXCHANGER					
Type *		HFP	HFP	HFP	HFP
FAN					
Type *		DPT	DPT	DPT	DPT
Drive *		Phase cut	Phase cut	VFD	VFD
Diameter	mm	450	450	800	800
Nominal air flow	l/s	22128	22128	25074	28656
Air Temperature	°C	35	35	35	35
Quantity	No.	16	16	7	8
Speed	rpm	1108	1108	600	600
Motor input	kW	6.3	6.3	4	4.6
COMPRESSOR					
Type		Scroll	Scroll	Scroll	Scroll
Oil charge	l	16.5	17.7	19.6	21.4
Quantity	No.	4	4	4	4
SOUND LEVEL**					
Sound Power - Cooling	dB(A)	85.0	85.9	83.6	84.3
Sound Pressure level@1m distance - Cooling	dB(A)	65.5	66.4	63.6	64.3
REFRIGERANT CIRCUIT					
Refrigerant type		R32	R32	R32	R32
Refrigerant charge	kg	50	55	70	70
N. of circuits	No.	2	2	2	2
PIPING CONNECTIONS					
Evaporator water inlet/outlet	mm	88.9	88.9	88.9	88.9

TECHNICAL SPECIFICATION

MODEL		EWYT400B-XRA2	EWYT440B-XRA2	EWYT500B-XRA2	EWYT560B-XRA2	EWYT600B-XRA2	EWYT630B-XRA2	EWYT650B-XRA2
COOLING PERFORMANCE								
Capacity - Cooling	kW	364	398	458	507	548	583	600
Capacity control - Type		Step	Step	Step	Step	Step	Step	Step
Capacity control - Minimum capacity	%	17	25	22	19	18	17	17
Unit power input - Cooling	kW	124	136	160	180	196	208	203
EER		2.93	2.91	2.85	2.81	2.8	2.8	2.94
SEER		4.82	4.63	4.92	4.89	4.83	4.79	4.72
IPLV		5.26	5.12	5.34	5.32	5.22	5.23	5.19
CASING								
Colour *		IW	IW	IW	IW	IW	IW	IW
Material *		GPSS	GPSS	GPSS	GPSS	GPSS	GPSS	GPSS
DIMENSIONS								
Height	mm	2516	2527	2527	2527	2527	2527	2527
Width	mm	2224	2224	2224	2224	2224	2224	2224
Length	mm	5211	5211	6112	6112	7010	7010	7010
WEIGHT								
Unit Weight	kg	3716	4035	4337	4586	4922	5089	5089
Operating Weight	kg	3751	4097	4399	4656	4992	5159	5159
WATER HEAT EXCHANGER								
Type *		PHE	PHE	PHE	PHE	PHE	PHE	PHE
Fluid		Water	Water	Water	Water	Water	Water	Water
Fouling Factor	m ² C/W	0	0	0	0	0	0	0
Water Volume	l	35	62	62	70	70	70	70
Water temperature in	°C	12	12	12	12	12	12	12
Water temperature out	°C	7	7	7	7	7	7	7
Water flow rate	l/s	17.3	19	21.8	24.2	26.2	27.8	28.6
Water pressure drop	kPa	33.5	22.7	29.2	32.2	37.1	41.4	43.7
Insulation material *		Closed Cell	Closed Cell	Closed Cell	Closed Cell	Closed Cell	Closed Cell	Closed Cell
AIR HEAT EXCHANGER								
Type *		HFP	HFP	HFP	HFP	HFP	HFP	HFP
FAN								
Type *		DPT	DPT	DPT	DPT	DPT	DPT	DPT
Drive *		VFD	VFD	VFD	VFD	VFD	VFD	VFD
Diameter	mm	800	800	800	800	800	800	800
Nominal air flow	l/s	36808	35820	44169	42984	51531	50148	66104
Air Temperature	°C	35	35	35	35	35	35	35
Quantity	No.	10	10	12	12	14	14	14
Speed	rpm	600	600	600	600	600	600	780
Motor input	kW	5.9	5.9	7.1	7.1	8.3	8.3	15.8
COMPRESSOR								
Type		Scroll	Scroll	Scroll	Scroll	Scroll	Scroll	Scroll
Oil charge	l	23.3	25.2	29.6	34	35.9	37.8	37.8
Quantity	No.	4	4	5	6	6	6	6
SOUND LEVEL **								
Sound Power - Cooling	dB(A)	85.2	85.5	86.2	86.3	86.9	87.1	91.6
Sound Pressure level@1m distance - Cooling	dB(A)	64.8	65.1	65.4	65.5	65.8	66.0	70.5
REFRIGERANT CIRCUIT								
Refrigerant type		R32	R32	R32	R32	R32	R32	R32
Refrigerant charge	kg	85	100	114.5	129	143.5	158	158
N. of circuits	No.	2	2	2	2	2	2	2
PIPING CONNECTIONS								
Evaporator water inlet/outlet	mm	88.9	88.9	88.9	88.9	88.9	88.9	88.9

EWYT~B-SS

MODEL		EWYT085B-SSA1	EWYT105B-SSA1	EWYT135B-SSA1	EWYT175B-SSA1	EWYT205B-SSA2	EWYT215B-SSA1
HEATING PERFORMANCE							
Capacity - Heating	kW	82.24	106.24	132.23	169.8	209.28	213.33
Unit power input - Heating	kW	28.22	36.59	45.39	59.06	72.51	73.98
COP		2.914	2.903	2.914	2.875	2.886	2.884
SCOP		3.34	3.41	3.36	3.4	3.37	3.4
HEAT EXCHANGER - EVAPORATOR							
Water temperature in	°C	40	40	40	40	40	40
Water temperature out	°C	45	45	45	45	45	45
FAN							
Air Temperature		7	7	7	7	7	7

MODEL		EWYT235B-SSA2	EWYT255B-SSA2	EWYT300B-SSA2	EWYT340B-SSA2	EWYT390B-SSA2
HEATING PERFORMANCE						
Capacity - Heating	kW	236.16	256.09	300.01	342.79	389.93
Unit power input - Heating	kW	82.26	87.15	104.12	116.23	135.61
COP		2.871	2.938	2.882	2.949	2.875
SCOP		3.34	3.29	3.27	3.28	3.35
HEAT EXCHANGER - EVAPORATOR						
Water temperature in	°C	40	40	40	40	40
Water temperature out	°C	45	45	45	45	45
FAN						
Air Temperature		7	7	7	7	7

MODEL		EWYT430B-SSA2	EWYT490B-SSA2	EWYT540B-SSA2	EWYT590B-SSA2	EWYT630B-SSA2
HEATING PERFORMANCE						
Capacity - Heating	kW	432.79	486.98	541.54	591.29	627.45
Unit power input - Heating	kW	150.48	166.78	185.15	201.91	214.4
COP		2.876	2.92	2.925	2.928	2.927
SCOP		3.33	3.37	3.35	3.38	3.37
HEAT EXCHANGER - EVAPORATOR						
Water temperature in	°C	40	40	40	40	40
Water temperature out	°C	45	45	45	45	45
FAN						
Air Temperature		7	7	7	7	7

EWYT~B-SL

MODEL		EWYT085B-SLA1	EWYT105B-SLA1	EWYT135B-SLA1	EWYT175B-SLA1	EWYT205B-SLA2	EWYT215B-SLA1
HEATING PERFORMANCE							
Capacity - Heating	kW	82.24	106.24	132.23	169.8	209.28	213.33
Unit power input - Heating	kW	28.22	36.59	45.39	59.06	72.51	73.98
COP		2.914	2.903	2.914	2.875	2.886	2.884
SCOP		3.34	3.41	3.36	3.4	3.37	3.4
HEAT EXCHANGER - EVAPORATOR							
Water temperature in	°C	40	40	40	40	40	40
Water temperature out	°C	45	45	45	45	45	45
FAN							
Air Temperature		7	7	7	7	7	7

MODEL		EWYT235B-SLA2	EWYT255B-SLA2	EWYT300B-SLA2	EWYT340B-SLA2	EWYT390B-SLA2
HEATING PERFORMANCE						
Capacity - Heating	kW	236.16	256.09	300.01	342.79	389.93
Unit power input - Heating	kW	82.26	87.15	104.12	116.23	135.61
COP		2.871	2.938	2.882	2.949	2.875
SCOP		3.34	3.29	3.27	3.28	3.35
HEAT EXCHANGER - EVAPORATOR						
Water temperature in	°C	40	40	40	40	40
Water temperature out	°C	45	45	45	45	45
FAN						
Air Temperature		7	7	7	7	7

MODEL		EWYT430B-SLA2	EWYT490B-SLA2	EWYT540B-SLA2	EWYT590B-SLA2	EWYT630B-SLA2
HEATING PERFORMANCE						
Capacity - Heating	kW	432.79	486.98	541.54	591.29	627.45
Unit power input - Heating	kW	150.48	166.78	185.15	201.91	214.4
COP		2.876	2.92	2.925	2.928	2.927
SCOP		3.33	3.37	3.35	3.38	3.37
HEAT EXCHANGER - EVAPORATOR						
Water temperature in	°C	40	40	40	40	40
Water temperature out	°C	45	45	45	45	45
FAN						
Air Temperature		7	7	7	7	7

EWYT~B-SR

MODEL		EWYT085B-SRA1	EWYT105B-SRA1	EWYT135B-SRA1	EWYT175B-SRA1	EWYT205B-SRA2	EWYT215B-SRA1
HEATING PERFORMANCE							
Capacity - Heating	kW	81.00	105.24	131.02	167.00	207.00	210.00
Unit power input - Heating	kW	26.4	36.24	44.84	54.67	67.74	68.31
COP		2.89	2.904	2.922	2.86	2.88	2.87
SCOP		3.35	3.4	3.37	3.42	3.44	3.43
HEAT EXCHANGER - EVAPORATOR							
Water temperature in	°C	40	40	40	40	40	40
Water temperature out	°C	45	45	45	45	45	45
FAN							
Air Temperature		7	7	7	7	7	7

MODEL		EWYT235B-SRA2	EWYT255B-SRA2	EWYT300B-SRA2	EWYT340B-SRA2	EWYT390B-SRA2
HEATING PERFORMANCE						
Capacity - Heating	kW	233.00	251.00	295.81	335.24	384.62
Unit power input - Heating	kW	77.26	80.08	101.89	113.31	131.71
COP		2.86	2.91	2.903	2.959	2.92
SCOP		3.32	3.33	3.42	3.49	3.49
HEAT EXCHANGER - EVAPORATOR						
Water temperature in	°C	40	40	40	40	40
Water temperature out	°C	45	45	45	45	45
FAN						
Air Temperature		7	7	7	7	7

MODEL		EWYT430B-SRA2	EWYT490B-SRA2	EWYT540B-SRA2	EWYT590B-SRA2	EWYT630B-SRA2
HEATING PERFORMANCE						
Capacity - Heating	kW	426.79	477.49	528.73	581.03	615.34
Unit power input - Heating	kW	144.34	160.28	178.33	194.13	206.57
COP		2.957	2.979	2.965	2.993	2.979
SCOP		3.57	3.65	3.6	3.67	3.66
HEAT EXCHANGER - EVAPORATOR						
Water temperature in	°C	40	40	40	40	40
Water temperature out	°C	45	45	45	45	45
FAN						
Air Temperature		7	7	7	7	7

EWYT~B-XS

MODEL		EWYT085B-XSA1	EWYT115B-XSA1	EWYT135B-XSA1	EWYT175B-XSA1	EWYT215B-XSA1	EWYT215B-XSA2
HEATING PERFORMANCE							
Capacity - Heating	kW	85.86	111.02	133.18	176.29	218.29	214.81
Unit power input - Heating	kW	26.06	33.19	39.11	51.68	64.91	62.55
COP		3.295	3.345	3.405	3.411	3.363	3.434
SCOP		3.7	3.72	3.7	3.67	3.66	3.7
HEAT EXCHANGER - EVAPORATOR							
Water temperature in	°C	40	40	40	40	40	40
Water temperature out	°C	45	45	45	45	45	45
FAN							
Air Temperature		7	7	7	7	7	7

MODEL		EWYT235B-XSA2	EWYT265B-XSA2	EWYT310B-XSA2	EWYT350B-XSA2
HEATING PERFORMANCE					
Capacity - Heating	kW	239.37	260.83	305.53	349.96
Unit power input - Heating	kW	69.49	76.15	88.61	101.7
COP		3.444	3.425	3.448	3.441
SCOP		3.86	3.77	3.9	3.9
HEAT EXCHANGER - EVAPORATOR					
Water temperature in	°C	40	40	40	40
Water temperature out	°C	45	45	45	45
FAN					
Air Temperature		7	7	7	7

MODEL		EWYT400B-XSA2	EWYT440B-XSA2	EWYT500B-XSA2	EWYT560B-XSA2	EWYT600B-XSA2	EWYT630B-XSA2	EWYT650B-XSA2
HEATING PERFORMANCE								
Capacity - Heating	kW	400.64	443.87	500.13	555.95	598.67	633.91	649.7
Unit power input - Heating	kW	117.65	127.8	147.3	165.04	179.94	191.66	203.16
COP		3.405	3.473	3.395	3.369	3.327	3.308	3.198
SCOP		3.82	3.85	3.83	3.81	3.79	3.76	3.53
HEAT EXCHANGER - EVAPORATOR								
Water temperature in	°C	40	40	40	40	40	40	40
Water temperature out	°C	45	45	45	45	45	45	45
FAN								
Air Temperature		7	7	7	7	7	7	7

EWYT~B-XL

MODEL		EWYT085B-XLA1	EWYT115B-XLA1	EWYT135B-XLA1	EWYT175B-XLA1	EWYT215B-XLA1	EWYT215B-XLA2
HEATING PERFORMANCE							
Capacity - Heating	kW	85.86	111.02	133.18	176.29	218.29	214.81
Unit power input - Heating	kW	26.06	33.19	39.11	51.68	64.91	62.55
COP		3.295	3.345	3.405	3.411	3.363	3.434
SCOP		3.7	3.72	3.7	3.67	3.66	3.7
HEAT EXCHANGER - EVAPORATOR							
Water temperature in	°C	40	40	40	40	40	40
Water temperature out	°C	45	45	45	45	45	45
FAN							
Air Temperature		7	7	7	7	7	7

MODEL		EWYT235B-XLA2	EWYT265B-XLA2	EWYT310B-XLA2	EWYT350B-XLA2
HEATING PERFORMANCE					
Capacity - Heating	kW	239.37	260.83	305.53	349.96
Unit power input - Heating	kW	69.49	76.15	88.61	101.7
COP		3.444	3.425	3.448	3.441
SCOP		3.86	3.77	3.9	3.9
HEAT EXCHANGER - EVAPORATOR					
Water temperature in	°C	40	40	40	40
Water temperature out	°C	45	45	45	45
FAN					
Air Temperature		7	7	7	7

MODEL		EWYT400B-XLA2	EWYT440B-XLA2	EWYT500B-XLA2	EWYT560B-XLA2	EWYT600B-XLA2	EWYT630B-XLA2	EWYT650B-XLA2
HEATING PERFORMANCE								
Capacity - Heating	kW	400.64	443.87	500.13	555.95	598.67	633.91	649.7
Unit power input - Heating	kW	117.65	127.8	147.3	165.04	179.94	191.66	203.16
COP		3.405	3.473	3.395	3.369	3.327	3.308	3.198
SCOP		3.82	3.85	3.83	3.81	3.79	3.76	3.53
HEAT EXCHANGER - EVAPORATOR								
Water temperature in	°C	40	40	40	40	40	40	40
Water temperature out	°C	45	45	45	45	45	45	45
FAN								
Air Temperature		7	7	7	7	7	7	7

EWYT~B-XR

MODEL		EWYT085B-XRA1	EWYT115B-XRA1	EWYT135B-XRA1	EWYT175B-XRA1	EWYT215B-XRA1	EWYT215B-XRA2
HEATING PERFORMANCE							
Capacity - Heating	kW	84.9	110.32	132.02	174.14	216.57	213.48
Unit power input - Heating	kW	25.87	32.94	38.82	51.3	64.51	62.13
COP		3.282	3.349	3.401	3.394	3.357	3.436
SCOP		3.66	3.71	3.65	3.83	3.74	3.7
HEAT EXCHANGER - EVAPORATOR							
Water temperature in	°C	40	40	40	40	40	40
Water temperature out	°C	45	45	45	45	45	45
FAN							
Air Temperature		7	7	7	7	7	7

MODEL		EWYT235B-XRA2	EWYT265B-XRA2	EWYT310B-XRA2	EWYT350B-XRA2
HEATING PERFORMANCE					
Capacity - Heating	kW	237.57	256.58	301.04	344.8
Unit power input - Heating	kW	68.99	75.49	86.19	98.95
COP		3.443	3.399	3.493	3.485
SCOP		3.82	3.81	4.06	4.01
HEAT EXCHANGER - EVAPORATOR					
Water temperature in	°C	40	40	40	40
Water temperature out	°C	45	45	45	45
FAN					
Air Temperature		7	7	7	7

MODEL		EWYT400B-XRA2	EWYT440B-XRA2	EWYT500B-XRA2	EWYT560B-XRA2	EWYT600B-XRA2	EWYT630B-XRA2	EWYT650B-XRA2
HEATING PERFORMANCE								
Capacity - Heating	kW	395.81	438.23	494.13	549.6	588.57	620.71	637.4
Unit power input - Heating	kW	114.46	124.61	143.5	161.2	175.33	186.93	193.22
COP		3.458	3.517	3.443	3.409	3.357	3.321	3.299
SCOP		3.95	4.03	3.99	4.04	4	3.98	3.88
HEAT EXCHANGER - EVAPORATOR								
Water temperature in	°C	40	40	40	40	40	40	40
Water temperature out	°C	45	45	45	45	45	45	45
FAN								
Air Temperature		7	7	7	7	7	7	7

All the cooling performances (Cooling capacity, unit power input in cooling and EER) are based on the following conditions: 12,0/7,0°C; ambient 35,0°C, unit at full load operation; operating fluid: Water; fouling factor = 0. EN14511:2018

All the heating performances (Heating capacity, unit power input in heating and COP) are based on the following conditions: 40,0/45,0°C; ambient 7,0°C, unit at full load operation; operating fluid: Water; fouling factor = 0. EN14511:2018

The values of SCOP and η_s are calculated in accordance with the Ecodesign regulation No. 813/2013 and the standard EN 14825, these units are classified as "Low Temperature Heat Pumps".

SCOP calculation is based on the following conditions: T_{bivalent} -5 °C, T_{design} -10 °C, Average Climate.

SEER is calculated in accordance with the regulation No. 2281/2016 and standard EN14825 for information only, unless the unit is a "cooling-only" type.

* PHE: Plate Heat Exchanger; S&T: Single Pass Shell & Tube; MCH: Microchannel; DPT: Direct Propeller Type; DOL: Direct On Line - VFD: Inverter

** Sound power level is measured in cooling mode at full load (referred to 12/7°C, ambient 35°C) in accordance with ISO 9614 and Eurovent requirements. The certification refers only to the overall sound power level, the sound pressure is calculated from the sound power level and are for information only and not considered binding.

The minimum capacity indicated is referred to unit operating at standard Eurovent conditions.

Dimensions and weights are for indication only and not considered binding. Before designing the installation, consult the official drawings available from the factory at request.

All the data are referred to standard unit without options. All data are subject to change without notice. The values of the Pressure Drops refer to the pressure drops in the Water heat exchanger only.

EWYT~B-SS

MODEL		EWYT085B-SSA1	EWYT105B-SSA1	EWYT135B-SSA1	EWYT175B-SSA1	EWYT205B-SSA2	EWYT215B-SSA1
POWER SUPPLY							
Phases	No.	3	3	3	3	3	3
Frequency	Hz	50	50	50	50	50	50
Voltage	V	400	400	400	400	400	400
Voltage tolerance Minimum	%	-10%	-10%	-10%	-10%	-10%	-10%
Voltage tolerance Maximum	%	10%	10%	10%	10%	10%	10%
UNIT							
Maximum inrush current	A	211	327	343	464	408	495
Nominal running current cooling	A	54	66	76	99	125	123
Maximum running current	A	68	85	101	131	166	163
Maximum current for wires sizing	A	75	94	111	144	183	179
FANS							
Nominal running current cooling	A	4	6	8	8	10	10
COMPRESSORS							
Phases	No.	3	3	3	3	3	3
Voltage	V	400	400	400	400	400	400
Voltage tolerance Minimum	%	-10%	-10%	-10%	-10%	-10%	-10%
Voltage tolerance Maximum	%	10%	10%	10%	10%	10%	10%
Maximum running current	A	64	92	89	146	184	151
Starting method		DOL	DOL	DOL	DOL	DOL	DOL

MODEL		EWYT235B-SSA2	EWYT255B-SSA2	EWYT300B-SSA2	EWYT340B-SSA2	EWYT390B-SSA2
POWER SUPPLY						
Phases	No.	3	3	3	3	3
Frequency	Hz	50	50	50	50	50
Voltage	V	400	400	400	400	400
Voltage tolerance Minimum	%	-10%	-10%	-10%	-10%	-10%
Voltage tolerance Maximum	%	10%	10%	10%	10%	10%
UNIT						
Maximum inrush current	A	425	439	564	598	636
Nominal running current cooling	A	134	146	174	198	227
Maximum running current	A	183	197	232	266	304
Maximum current for wires sizing	A	201	217	255	293	334
FANS						
Nominal running current cooling	A	12	12	18	21	28
COMPRESSORS						
Phases	No.	3	3	3	3	3
Voltage	V	400	400	400	400	400
Voltage tolerance Minimum	%	-10%	-10%	-10%	-10%	-10%
Voltage tolerance Maximum	%	10%	10%	10%	10%	10%
Maximum running current	A	181	177	235	292	297
Starting method		DOL	DOL	DOL	DOL	DOL

MODEL		EWYT430B-SSA2	EWYT490B-SSA2	EWYT540B-SSA2	EWYT590B-SSA2	EWYT630B-SSA2
POWER SUPPLY						
Phases	No.	3	3	3	3	3
Frequency	Hz	50	50	50	50	50
Voltage	V	400	400	400	400	400
Voltage tolerance Minimum	%	-10%	-10%	-10%	-10%	-10%
Voltage tolerance Maximum	%	10%	10%	10%	10%	10%
UNIT						
Maximum inrush current	A	666	712	757	795	825
Nominal running current cooling	A	253	291	328	353	372
Maximum running current	A	334	379	425	463	493
Maximum current for wires sizing	A	367	417	468	509	542
FANS						
Nominal running current cooling	A	28	28	28	35	35
COMPRESSORS						
Phases	No.	3	3	3	3	3
Voltage	V	400	400	400	400	400
Voltage tolerance Minimum	%	-10%	-10%	-10%	-10%	-10%
Voltage tolerance Maximum	%	10%	10%	10%	10%	10%
Maximum running current	A	301	372	443	447	452
Starting method		DOL	DOL	DOL	DOL	DOL

EWYT~B-SL

MODEL		EWYT085B-SLA1	EWYT105B-SLA1	EWYT135B-SLA1	EWYT175B-SLA1	EWYT205B-SLA2	EWYT215B-SLA1
POWER SUPPLY							
Phases	No.	3	3	3	3	3	3
Frequency	Hz	50	50	50	50	50	50
Voltage	V	400	400	400	400	400	400
Voltage tolerance Minimum	%	-10%	-10%	-10%	-10%	-10%	-10%
Voltage tolerance Maximum	%	10%	10%	10%	10%	10%	10%
UNIT							
Maximum inrush current	A	211	327	343	464	408	495
Nominal running current cooling	A	54	66	76	99	125	123
Maximum running current	A	68	85	101	131	166	163
Maximum current for wires sizing	A	75	94	111	144	183	179
FANS							
Nominal running current cooling	A	4	6	8	8	10	10
COMPRESSORS							
Phases	No.	3	3	3	3	3	3
Voltage	V	400	400	400	400	400	400
Voltage tolerance Minimum	%	-10%	-10%	-10%	-10%	-10%	-10%
Voltage tolerance Maximum	%	10%	10%	10%	10%	10%	10%
Maximum running current	A	64	92	89	146	184	151
Starting method		DOL	DOL	DOL	DOL	DOL	DOL

MODEL		EWYT235B-SLA2	EWYT255B-SLA2	EWYT300B-SLA2	EWYT340B-SLA2	EWYT390B-SLA2
POWER SUPPLY						
Phases	No.	3	3	3	3	3
Frequency	Hz	50	50	50	50	50
Voltage	V	400	400	400	400	400
Voltage tolerance Minimum	%	-10%	-10%	-10%	-10%	-10%
Voltage tolerance Maximum	%	10%	10%	10%	10%	10%
UNIT						
Maximum inrush current	A	425	439	564	598	636
Nominal running current cooling	A	134	146	174	198	227
Maximum running current	A	183	197	232	266	304
Maximum current for wires sizing	A	201	217	255	293	334
FANS						
Nominal running current cooling	A	12	12	18	21	28
COMPRESSORS						
Phases	No.	3	3	3	3	3
Voltage	V	400	400	400	400	400
Voltage tolerance Minimum	%	-10%	-10%	-10%	-10%	-10%
Voltage tolerance Maximum	%	10%	10%	10%	10%	10%
Maximum running current	A	181	177	235	292	297
Starting method		DOL	DOL	DOL	DOL	DOL

MODEL		EWYT430B-SLA2	EWYT490B-SLA2	EWYT540B-SLA2	EWYT590B-SLA2	EWYT630B-SLA2
POWER SUPPLY						
Phases	No.	3	3	3	3	3
Frequency	Hz	50	50	50	50	50
Voltage	V	400	400	400	400	400
Voltage tolerance Minimum	%	-10%	-10%	-10%	-10%	-10%
Voltage tolerance Maximum	%	10%	10%	10%	10%	10%
UNIT						
Maximum inrush current	A	666	712	757	795	825
Nominal running current cooling	A	253	291	328	353	372
Maximum running current	A	334	379	425	463	493
Maximum current for wires sizing	A	367	417	468	509	542
FANS						
Nominal running current cooling	A	28	28	28	35	35
COMPRESSORS						
Phases	No.	3	3	3	3	3
Voltage	V	400	400	400	400	400
Voltage tolerance Minimum	%	-10%	-10%	-10%	-10%	-10%
Voltage tolerance Maximum	%	10%	10%	10%	10%	10%
Maximum running current	A	301	372	443	447	452
Starting method		DOL	DOL	DOL	DOL	DOL

EWYT~B-SR

MODEL		EWYT085B-SRA1	EWYT105B-SRA1	EWYT135B-SRA1	EWYT175B-SRA1	EWYT205B-SRA2	EWYT215B-SRA1
POWER SUPPLY							
Phases	No.	3	3	3	3	3	3
Frequency	Hz	50	50	50	50	50	50
Voltage	V	400	400	400	400	400	400
Voltage tolerance Minimum	%	-10%	-10%	-10%	-10%	-10%	-10%
Voltage tolerance Maximum	%	10%	10%	10%	10%	10%	10%
UNIT							
Maximum inrush current	A	211	327	343	464	408	495
Nominal running current cooling	A	55	67	77	101	128	126
Maximum running current	A	68	85	101	131	166	163
Maximum current for wires sizing	A	75	94	111	144	183	179
FANS							
Nominal running current cooling	A	4	6	8	8	9	9
COMPRESSORS							
Phases	No.	3	3	3	3	3	3
Voltage	V	400	400	400	400	400	400
Voltage tolerance Minimum	%	-10%	-10%	-10%	-10%	-10%	-10%
Voltage tolerance Maximum	%	10%	10%	10%	10%	10%	10%
Maximum running current	A	64	92	89	146	184	151
Starting method		DOL	DOL	DOL	DOL	DOL	DOL

MODEL		EWYT235B-SRA2	EWYT255B-SRA2	EWYT300B-SRA2	EWYT340B-SRA2	EWYT390B-SRA2
POWER SUPPLY						
Phases	No.	3	3	3	3	3
Frequency	Hz	50	50	50	50	50
Voltage	V	400	400	400	400	400
Voltage tolerance Minimum	%	-10%	-10%	-10%	-10%	-10%
Voltage tolerance Maximum	%	10%	10%	10%	10%	10%
UNIT						
Maximum inrush current	A	425	439	564	598	636
Nominal running current cooling	A	136	149	173	196	223
Maximum running current	A	183	197	232	266	304
Maximum current for wires sizing	A	201	217	255	292	334
FANS						
Nominal running current cooling	A	11	11	11	13	18
COMPRESSORS						
Phases	No.	3	3	3	3	3
Voltage	V	400	400	400	400	400
Voltage tolerance Minimum	%	-10%	-10%	-10%	-10%	-10%
Voltage tolerance Maximum	%	10%	10%	10%	10%	10%
Maximum running current	A	181	177	235	292	297
Starting method		DOL	DOL	DOL	DOL	DOL

MODEL		EWYT430B-SRA2	EWYT490B-SRA2	EWYT540B-SRA2	EWYT590B-SRA2	EWYT630B-SRA2
POWER SUPPLY						
Phases	No.	3	3	3	3	3
Frequency	Hz	50	50	50	50	50
Voltage	V	400	400	400	400	400
Voltage tolerance Minimum	%	-10%	-10%	-10%	-10%	-10%
Voltage tolerance Maximum	%	10%	10%	10%	10%	10%
UNIT						
Maximum inrush current	A	666	712	757	795	825
Nominal running current cooling	A	251	292	330	353	373
Maximum running current	A	334	379	425	463	493
Maximum current for wires sizing	A	367	417	468	509	542
FANS						
Nominal running current cooling	A	18	18	18	23	23
COMPRESSORS						
Phases	No.	3	3	3	3	3
Voltage	V	400	400	400	400	400
Voltage tolerance Minimum	%	-10%	-10%	-10%	-10%	-10%
Voltage tolerance Maximum	%	10%	10%	10%	10%	10%
Maximum running current	A	301	372	443	447	452
Starting method		DOL	DOL	DOL	DOL	DOL

EWYT~B-XS

MODEL		EWYT085B-XSA1	EWYT115B-XSA1	EWYT135B-XSA1	EWYT175B-XSA1	EWYT215B-XSA1	EWYT215B-XSA2
POWER SUPPLY							
Phases	No.	3	3	3	3	3	3
Frequency	Hz	50	50	50	50	50	50
Voltage	V	400	400	400	400	400	400
Voltage tolerance Minimum	%	-10%	-10%	-10%	-10%	-10%	-10%
Voltage tolerance Maximum	%	10%	10%	10%	10%	10%	10%
UNIT							
Maximum inrush current	A	213	329	343	465	497	412
Nominal running current cooling	A	53	65	75	99	123	122
Maximum running current	A	70	87	101	133	165	170
Maximum current for wires sizing	A	77	96	111	146	182	187
FANS							
Nominal running current cooling	A	6	8	8	9	11	13
COMPRESSORS							
Phases	No.	3	3	3	3	3	3
Voltage	V	400	400	400	400	400	400
Voltage tolerance Minimum	%	-10%	-10%	-10%	-10%	-10%	-10%
Voltage tolerance Maximum	%	10%	10%	10%	10%	10%	10%
Maximum running current	A	64	92	89	146	151	184
Starting method		DOL	DOL	DOL	DOL	DOL	DOL

MODEL		EWYT235B-XSA2	EWYT265B-XSA2	EWYT310B-XSA2	EWYT350B-XSA2
POWER SUPPLY					
Phases	No.	3	3	3	3
Frequency	Hz	50	50	50	50
Voltage	V	400	400	400	400
Voltage tolerance Minimum	%	-10%	-10%	-10%	-10%
Voltage tolerance Maximum	%	10%	10%	10%	10%
UNIT					
Maximum inrush current	A	429	443	562	594
Nominal running current cooling	A	132	143	170	192
Maximum running current	A	186	201	229	262
Maximum current for wires sizing	A	205	221	252	288
FANS					
Nominal running current cooling	A	15	15	15	17
COMPRESSORS					
Phases	No.	3	3	3	3
Voltage	V	400	400	400	400
Voltage tolerance Minimum	%	-10%	-10%	-10%	-10%
Voltage tolerance Maximum	%	10%	10%	10%	10%
Maximum running current	A	181	177	235	292
Starting method		DOL	DOL	DOL	DOL

MODEL		EWYT400B-XSA2	EWYT440B-XSA2	EWYT500B-XSA2	EWYT560B-XSA2	EWYT600B-XSA2	EWYT630B-XSA2	EWYT650B-XSA2
POWER SUPPLY								
Phases	No.	3	3	3	3	3	3	3
Frequency	Hz	50	50	50	50	50	50	50
Voltage	V	400	400	400	400	400	400	400
Voltage tolerance Minimum	%	-10%	-10%	-10%	-10%	-10%	-10%	-10%
Voltage tolerance Maximum	%	10%	10%	10%	10%	10%	10%	10%
UNIT								
Maximum inrush current	A	629	659	710	755	790	820	841
Nominal running current cooling	A	215	236	276	313	338	358	361
Maximum running current	A	297	327	377	423	458	488	509
Maximum current for wires sizing	A	327	360	415	465	504	537	560
FANS								
Nominal running current cooling	A	21	21	25	25	29	29	49
COMPRESSORS								
Phases	No.	3	3	3	3	3	3	3
Voltage	V	400	400	400	400	400	400	400
Voltage tolerance Minimum	%	-10%	-10%	-10%	-10%	-10%	-10%	-10%
Voltage tolerance Maximum	%	10%	10%	10%	10%	10%	10%	10%
Maximum running current	A	297	301	372	443	447	452	452
Starting method		DOL	DOL	DOL	DOL	DOL	DOL	DOL

EWYT~B-XL

MODEL		EWYT085B-XLA1	EWYT115B-XLA1	EWYT135B-XLA1	EWYT175B-XLA1	EWYT215B-XLA1	EWYT215B-XLA2
POWER SUPPLY							
Phases	No.	3	3	3	3	3	3
Frequency	Hz	50	50	50	50	50	50
Voltage	V	400	400	400	400	400	400
Voltage tolerance Minimum	%	-10%	-10%	-10%	-10%	-10%	-10%
Voltage tolerance Maximum	%	10%	10%	10%	10%	10%	10%
UNIT							
Maximum inrush current	A	213	329	343	465	497	412
Nominal running current cooling	A	53	65	75	99	123	122
Maximum running current	A	70	87	101	133	165	170
Maximum current for wires sizing	A	77	96	111	146	182	187
FANS							
Nominal running current cooling	A	6	8	8	9	11	13
COMPRESSORS							
Phases	No.	3	3	3	3	3	3
Voltage	V	400	400	400	400	400	400
Voltage tolerance Minimum	%	-10%	-10%	-10%	-10%	-10%	-10%
Voltage tolerance Maximum	%	10%	10%	10%	10%	10%	10%
Maximum running current	A	64	92	89	146	151	184
Starting method		DOL	DOL	DOL	DOL	DOL	DOL

MODEL		EWYT235B-XLA2	EWYT265B-XLA2	EWYT310B-XLA2	EWYT350B-XLA2
POWER SUPPLY					
Phases	No.	3	3	3	3
Frequency	Hz	50	50	50	50
Voltage	V	400	400	400	400
Voltage tolerance Minimum	%	-10%	-10%	-10%	-10%
Voltage tolerance Maximum	%	10%	10%	10%	10%
UNIT					
Maximum inrush current	A	429	443	562	594
Nominal running current cooling	A	132	143	170	192
Maximum running current	A	186	201	229	262
Maximum current for wires sizing	A	205	221	252	288
FANS					
Nominal running current cooling	A	15	15	15	17
COMPRESSORS					
Phases	No.	3	3	3	3
Voltage	V	400	400	400	400
Voltage tolerance Minimum	%	-10%	-10%	-10%	-10%
Voltage tolerance Maximum	%	10%	10%	10%	10%
Maximum running current	A	181	177	235	292
Starting method		DOL	DOL	DOL	DOL

ELECTRICAL SPECIFICATION

MODEL		EWYT400B-XLA2	EWYT440B-XLA2	EWYT500B-XLA2	EWYT560B-XLA2	EWYT600B-XLA2	EWYT630B-XLA2	EWYT650B-XLA2
POWER SUPPLY								
Phases	No.	3	3	3	3	3	3	3
Frequency	Hz	50	50	50	50	50	50	50
Voltage	V	400	400	400	400	400	400	400
Voltage tolerance Minimum	%	-10%	-10%	-10%	-10%	-10%	-10%	-10%
Voltage tolerance Maximum	%	10%	10%	10%	10%	10%	10%	10%
UNIT								
Maximum inrush current	A	629	659	710	755	790	820	841
Nominal running current cooling	A	215	236	276	313	338	358	361
Maximum running current	A	297	327	377	423	458	488	509
Maximum current for wires sizing	A	327	360	415	465	504	537	560
FANS								
Nominal running current cooling	A	21	21	25	25	29	29	49
COMPRESSORS								
Phases	No.	3	3	3	3	3	3	3
Voltage	V	400	400	400	400	400	400	400
Voltage tolerance Minimum	%	-10%	-10%	-10%	-10%	-10%	-10%	-10%
Voltage tolerance Maximum	%	10%	10%	10%	10%	10%	10%	10%
Maximum running current	A	297	301	372	443	447	452	452
Starting method		DOL	DOL	DOL	DOL	DOL	DOL	DOL

EWYT~B-XR

MODEL		EWYT085B-XRA1	EWYT115B-XRA1	EWYT135B-XRA1	EWYT175B-XRA1	EWYT215B-XRA1	EWYT215B-XRA2
POWER SUPPLY							
Phases	No.	3	3	3	3	3	3
Frequency	Hz	50	50	50	50	50	50
Voltage	V	400	400	400	400	400	400
Voltage tolerance Minimum	%	-10%	-10%	-10%	-10%	-10%	-10%
Voltage tolerance Maximum	%	10%	10%	10%	10%	10%	10%
UNIT							
Maximum inrush current	A	213	329	343	465	497	412
Nominal running current cooling	A	53	65	75	100	124	123
Maximum running current	A	70	87	101	133	165	170
Maximum current for wires sizing	A	77	96	111	146	182	187
FANS							
Nominal running current cooling	A	5	7	7	9	11	13
COMPRESSORS							
Phases	No.	3	3	3	3	3	3
Voltage	V	400	400	400	400	400	400
Voltage tolerance Minimum	%	-10%	-10%	-10%	-10%	-10%	-10%
Voltage tolerance Maximum	%	10%	10%	10%	10%	10%	10%
Maximum running current	A	64	92	89	146	151	184
Starting method		DOL	DOL	DOL	DOL	DOL	DOL

MODEL		EWYT235B-XRA2	EWYT265B-XRA2	EWYT310B-XRA2	EWYT350B-XRA2
POWER SUPPLY					
Phases	No.	3	3	3	3
Frequency	Hz	50	50	50	50
Voltage	V	400	400	400	400
Voltage tolerance Minimum	%	-10%	-10%	-10%	-10%
Voltage tolerance Maximum	%	10%	10%	10%	10%
UNIT					
Maximum inrush current	A	429	443	572	606
Nominal running current cooling	A	133	145	169	192
Maximum running current	A	186	201	240	274
Maximum current for wires sizing	A	205	221	264	301
FANS					
Nominal running current cooling	A	14	14	10	11
COMPRESSORS					
Phases	No.	3	3	3	3
Voltage	V	400	400	400	400
Voltage tolerance Minimum	%	-10%	-10%	-10%	-10%
Voltage tolerance Maximum	%	10%	10%	10%	10%
Maximum running current	A	181	177	235	292
Starting method		DOL	DOL	DOL	DOL

MODEL		EWYT400B-XRA2	EWYT440B-XRA2	EWYT500B-XRA2	EWYT560B-XRA2	EWYT600B-XRA2	EWYT630B-XRA2	EWYT650B-XRA2
POWER SUPPLY								
Phases	No.	3	3	3	3	3	3	3
Frequency	Hz	50	50	50	50	50	50	50
Voltage	V	400	400	400	400	400	400	400
Voltage tolerance Minimum	%	-10%	-10%	-10%	-10%	-10%	-10%	-10%
Voltage tolerance Maximum	%	10%	10%	10%	10%	10%	10%	10%
UNIT								
Maximum inrush current	A	644	674	728	773	811	841	841
Nominal running current cooling	A	214	237	276	315	339	360	353
Maximum running current	A	312	342	395	441	479	509	509
Maximum current for wires sizing	A	343	376	435	485	527	560	560
FANS								
Nominal running current cooling	A	14	14	17	17	20	20	32
COMPRESSORS								
Phases	No.	3	3	3	3	3	3	3
Voltage	V	400	400	400	400	400	400	400
Voltage tolerance Minimum	%	-10%	-10%	-10%	-10%	-10%	-10%	-10%
Voltage tolerance Maximum	%	10%	10%	10%	10%	10%	10%	10%
Maximum running current	A	297	301	372	443	447	452	452
Starting method		DOL	DOL	DOL	DOL	DOL	DOL	DOL

Fluid: Water

Allowed voltage tolerance ± 10%, Voltage unbalance between phases must be within ± 3%.

Maximum starting current: In case of inverter driven units, no inrush current at start up is experienced.

Nominal current in cooling mode is referred to the following conditions: Water Side Heat Exchanger 12/7°C; ambient 35°C; compressors + fans current

Maximum running current is based on max compressor absorbed current in its envelope and max fans absorbed current

Maximum unit current for wires sizing is based on minimum allowed voltage

Maximum current for wires sizing: (compressors full load ampere + fans current) × 1,1

The data are referred to the standard unit without options

For the electrical data of the hydronic kit refer to "Options technical data"

All data are subject to change without notice, Please refer to unit nameplate data

EWYT~B-SS

	Sound pressure level at 1 m from the unit								Sound pressure	Sound Power
MODEL	63 Hz	125 Hz	250 Hz	500 Hz	1000 Hz	2000 Hz	4000 Hz	8000 Hz	db(A)	db (A)
EWYT085B-SSA1	69	68	64	63	61	59	54	49	66.4	83.8
EWYT105B-SSA1	71	70	66	65	63	63	57	50	69.4	87.2
EWYT135B-SSA1	72	71	67	66	65	66	59	51	70.9	89.1
EWYT175B-SSA1	72	71	67	66	68	68	60	52	72.6	90.8
EWYT215B-SSA1	72	71	67	67	70	68	61	52	73.7	92.2
EWYT205B-SSA2	72	72	68	67	65	66	59	52	71.2	89.9
EWYT235B-SSA2	73	72	68	67	66	67	60	52	72.0	91.0
EWYT255B-SSA2	73	73	69	68	66	68	61	53	72.7	91.7
EWYT300B-SSA2	80	74	74	72	69	67	60	56	74.5	94.0
EWYT340B-SSA2	81	75	74	72	70	68	61	57	75.4	94.9
EWYT390B-SSA2	82	76	75	73	71	69	62	58	75.9	95.9
EWYT430B-SSA2	82	76	75	73	72	69	62	58	76.3	96.3
EWYT490B-SSA2	82	77	76	74	72	70	63	59	76.6	96.6
EWYT540B-SSA2	82	76	75	74	72	70	63	59	76.8	96.8
EWYT590B-SSA2	82	77	76	74	73	70	63	59	77.1	97.5
EWYT630B-SSA2	82	77	76	74	73	71	64	59	77.4	97.8

EWYT~B-SL

	Sound pressure level at 1 m from the unit								Sound pressure	Sound Power
MODEL	63 Hz	125 Hz	250 Hz	500 Hz	1000 Hz	2000 Hz	4000 Hz	8000 Hz	db(A)	db (A)
EWYT085B-SLA1	69	68	64	63	60	57	52	46	65.3	82.7
EWYT105B-SLA1	71	70	65	64	62	60	54	48	67.4	85.2
EWYT135B-SLA1	72	71	67	65	63	62	55	48	68.6	86.8
EWYT175B-SLA1	72	71	67	65	65	63	57	49	69.6	87.8
EWYT215B-SLA1	72	71	67	66	66	64	57	50	70.5	89.0
EWYT205B-SLA2	72	71	67	66	64	62	56	49	69.0	87.7
EWYT235B-SLA2	73	72	68	66	64	63	57	50	69.6	88.6
EWYT255B-SLA2	73	72	68	67	65	64	57	50	70.0	89.0
EWYT300B-SLA2	80	72	71	69	65	62	57	56	71.3	90.8
EWYT340B-SLA2	81	73	72	70	66	63	58	57	72.1	91.6
EWYT390B-SLA2	82	74	73	71	67	64	59	58	72.8	92.8
EWYT430B-SLA2	82	74	73	71	67	64	59	58	72.9	92.9
EWYT490B-SLA2	82	74	73	71	67	64	59	58	72.9	92.9
EWYT540B-SLA2	82	74	73	71	67	64	59	58	73.0	93.0
EWYT590B-SLA2	82	75	74	72	67	65	59	59	73.5	93.9
EWYT630B-SLA2	82	75	74	72	67	65	59	59	73.5	93.9

Sound power level (referred to Water Side Heat Exchanger 12/7°C, ambient 35°C full load operation) are measured in accordance with ISO 9614 and Eurovent 8/1 for Eurovent certified units, The certification refers only to the overall sound power level. The sound data in the Octave band spectrum is for intended for reference only and not considering binding. The sound pressure is calculated from the sound power level and are for information only and not considered binding.

EWYT~B-SR

MODEL	Sound pressure level at 1 m from the unit								Sound pressure	Sound Power
	63 Hz	125 Hz	250 Hz	500 Hz	1000 Hz	2000 Hz	4000 Hz	8000 Hz	db(A)	db (A)
EWYT085B-SRA1	65	62	57	57	55	53	49	43	60.4	77.8
EWYT105B-SRA1	66	65	60	60	58	58	51	44	63.8	81.6
EWYT135B-SRA1	66	67	62	62	60	59	52	44	65.4	83.6
EWYT175B-SRA1	66	67	62	62	63	61	54	46	67.2	85.4
EWYT215B-SRA1	66	68	63	63	64	63	55	47	68.4	86.9
EWYT205B-SRA2	66	68	62	62	60	60	53	46	65.7	84.4
EWYT235B-SRA2	67	68	63	63	61	61	54	46	66.5	85.5
EWYT255B-SRA2	67	69	64	63	61	62	55	47	67.3	86.3
EWYT300B-SRA2	75	69	68	65	62	59	55	55	67.7	87.2
EWYT340B-SRA2	75	70	68	65	63	60	56	56	68.5	88.0
EWYT390B-SRA2	76	70	69	66	64	60	57	57	69.2	89.2
EWYT430B-SRA2	76	70	69	66	64	61	57	57	69.3	89.3
EWYT490B-SRA2	76	71	69	66	64	61	57	57	69.4	89.4
EWYT540B-SRA2	76	70	69	66	64	61	57	57	69.5	89.5
EWYT590B-SRA2	77	71	70	67	65	61	57	57	70.0	90.4
EWYT630B-SRA2	77	71	70	67	65	62	58	58	70.1	90.5

EWYT~B-XS

MODEL	Sound pressure level at 1 m from the unit								Sound pressure	Sound Power
	63 Hz	125 Hz	250 Hz	500 Hz	1000 Hz	2000 Hz	4000 Hz	8000 Hz	db(A)	db (A)
EWYT085B-XSA1	66	62	57	58	58	58	53	47	63.4	81.2
EWYT115B-XSA1	67	68	63	63	61	62	56	48	67.4	85.6
EWYT135B-XSA1	67	69	64	64	63	65	58	49	69.4	87.6
EWYT175B-XSA1	67	68	63	64	66	66	59	49	71.4	89.9
EWYT215B-XSA1	67	69	64	65	69	67	60	51	72.6	91.4
EWYT215B-XSA2	68	69	65	64	63	64	57	50	69.2	88.5
EWYT235B-XSA2	69	70	65	65	64	66	58	50	70.2	89.7
EWYT265B-XSA2	69	70	66	66	64	67	59	51	71.1	90.6
EWYT310B-XSA2	76	70	69	66	67	67	61	57	72.4	92.4
EWYT350B-XSA2	76	70	69	67	69	68	61	58	73.4	93.4
EWYT400B-XSA2	76	70	69	67	69	68	62	58	73.8	94.2
EWYT440B-XSA2	76	70	69	67	70	69	62	58	74.4	94.8
EWYT500B-XSA2	77	71	70	68	70	69	63	58	74.5	95.3
EWYT560B-XSA2	77	71	70	68	70	70	63	58	74.8	95.6
EWYT600B-XSA2	77	71	70	68	71	70	63	59	75.0	96.1
EWYT630B-XSA2	77	71	70	68	71	70	63	59	75.4	96.5
EWYT650B-XSA2	84	75	75	73	73	71	64	58	77.3	98.4

Sound power level (referred to Water Side Heat Exchanger 12/7°C, ambient 35°C full load operation) are measured in accordance with ISO 9614 and Eurovent 8/1 for Eurovent certified units, The certification refers only to the overall sound power level. The sound data in the Octave band spectrum is for intended for reference only and not considering binding. The sound pressure is calculated from the sound power level and are for information only and not considered binding.

EWYT~B-XL

MODEL	Sound pressure level at 1 m from the unit								Sound pressure	Sound Power
	63 Hz	125 Hz	250 Hz	500 Hz	1000 Hz	2000 Hz	4000 Hz	8000 Hz	db(A)	db (A)
EWYT085B-XLA1	66	63	58	58	56	53	49	43	61.2	79.5
EWYT115B-XLA1	67	66	61	60	58	58	51	44	63.9	82.6
EWYT135B-XLA1	67	66	61	61	59	60	53	45	65.4	84.1
EWYT175B-XLA1	67	66	61	61	63	62	55	46	67.2	86.2
EWYT215B-XLA1	67	66	61	62	64	63	55	46	68.2	87.5
EWYT215B-XLA2	68	67	62	62	60	60	53	46	65.6	85.4
EWYT235B-XLA2	69	68	63	62	60	61	54	46	66.4	86.4
EWYT265B-XLA2	69	68	63	63	61	62	55	46	67.1	87.1
EWYT310B-XLA2	76	67	66	63	61	58	54	54	66.4	86.4
EWYT350B-XLA2	76	68	67	64	62	59	55	55	67.1	87.1
EWYT400B-XLA2	76	69	67	64	63	59	55	55	67.6	88.0
EWYT440B-XLA2	76	69	67	64	63	60	55	55	67.8	88.2
EWYT500B-XLA2	77	69	68	65	63	60	56	56	68.1	88.9
EWYT560B-XLA2	77	69	68	65	63	60	56	56	68.2	89.0
EWYT600B-XLA2	77	69	68	65	63	60	56	56	68.5	89.6
EWYT630B-XLA2	77	69	68	65	64	60	56	56	68.6	89.7
EWYT650B-XLA2	84	76	75	73	68	63	58	57	74.2	95.3

EWYT~B-XR

MODEL	Sound pressure level at 1 m from the unit								Sound pressure	Sound pressure
	63 Hz	125 Hz	250 Hz	500 Hz	1000 Hz	2000 Hz	4000 Hz	8000 Hz	db(A)	db (A)
EWYT085B-XRA1	64	63	57	57	55	50	45	39	59.3	77.1
EWYT115B-XRA1	65	66	61	61	58	54	48	42	62.8	81.0
EWYT135B-XRA1	65	68	63	63	60	56	50	43	64.7	82.9
EWYT175B-XRA1	65	70	65	64	62	58	52	45	66.6	85.1
EWYT215B-XRA1	65	71	66	65	63	59	53	46	67.7	86.5
EWYT215B-XRA2	66	66	61	61	60	58	51	43	64.6	83.9
EWYT235B-XRA2	67	67	62	61	61	59	52	44	65.5	85.0
EWYT265B-XRA2	67	67	62	62	62	60	53	45	66.4	85.9
EWYT310B-XRA2	73	63	62	58	58	57	53	52	63.6	83.6
EWYT350B-XRA2	73	64	62	59	59	57	53	53	64.3	84.3
EWYT400B-XRA2	73	64	63	60	60	58	54	54	64.8	85.2
EWYT440B-XRA2	73	64	63	60	60	58	54	54	65.1	85.5
EWYT500B-XRA2	74	64	63	59	60	59	54	54	65.4	86.2
EWYT560B-XRA2	74	64	63	60	61	59	54	54	65.5	86.3
EWYT600B-XRA2	74	65	63	60	61	59	54	54	65.8	86.9
EWYT630B-XRA2	74	65	63	60	61	59	54	54	66.0	87.1
EWYT650B-XRA2	77	72	70	67	65	62	58	58	70.5	91.6

EWYT~B-S - (SILVER SERIES) - Parallel and Double-V Coil – HEATING

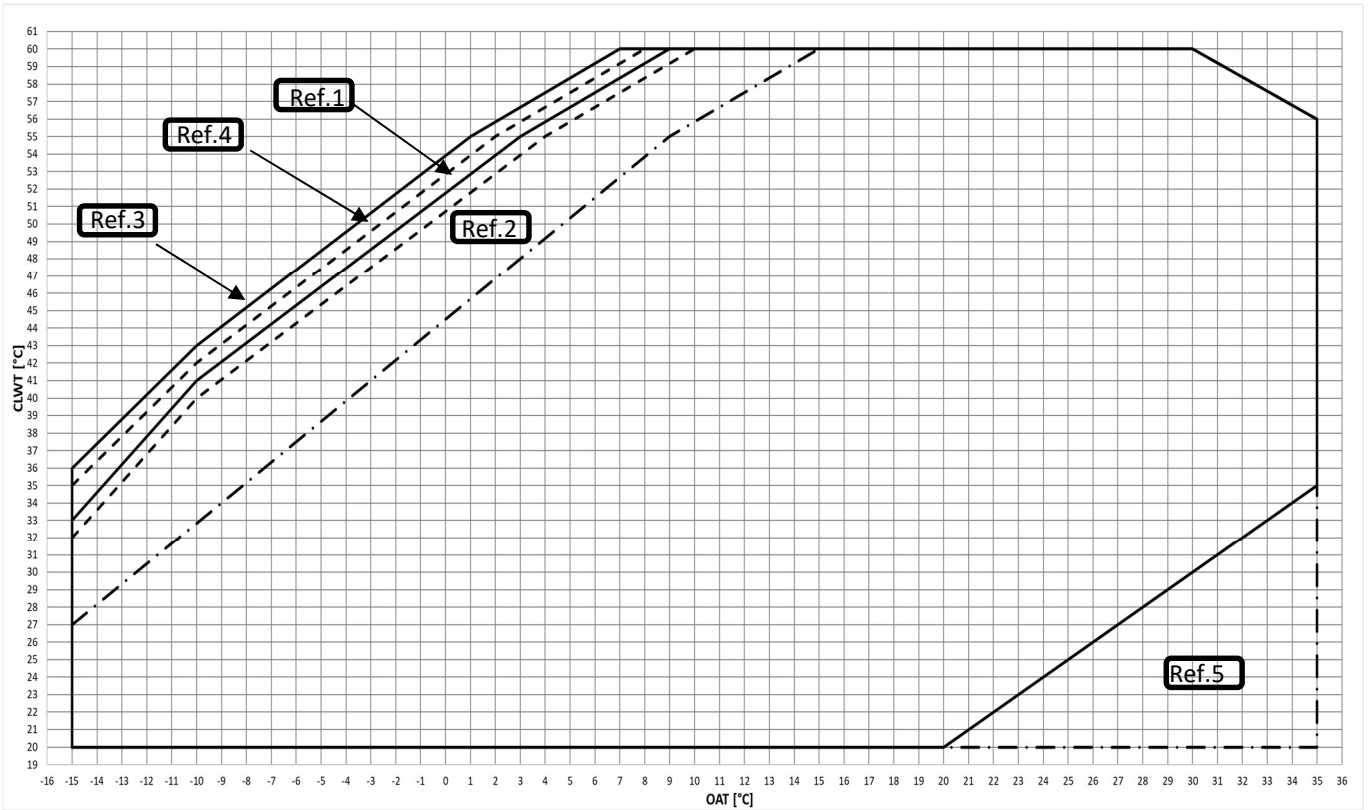

EWYT~B-X - (GOLD SERIES) - Parallel and Double-V Coil – HEATING

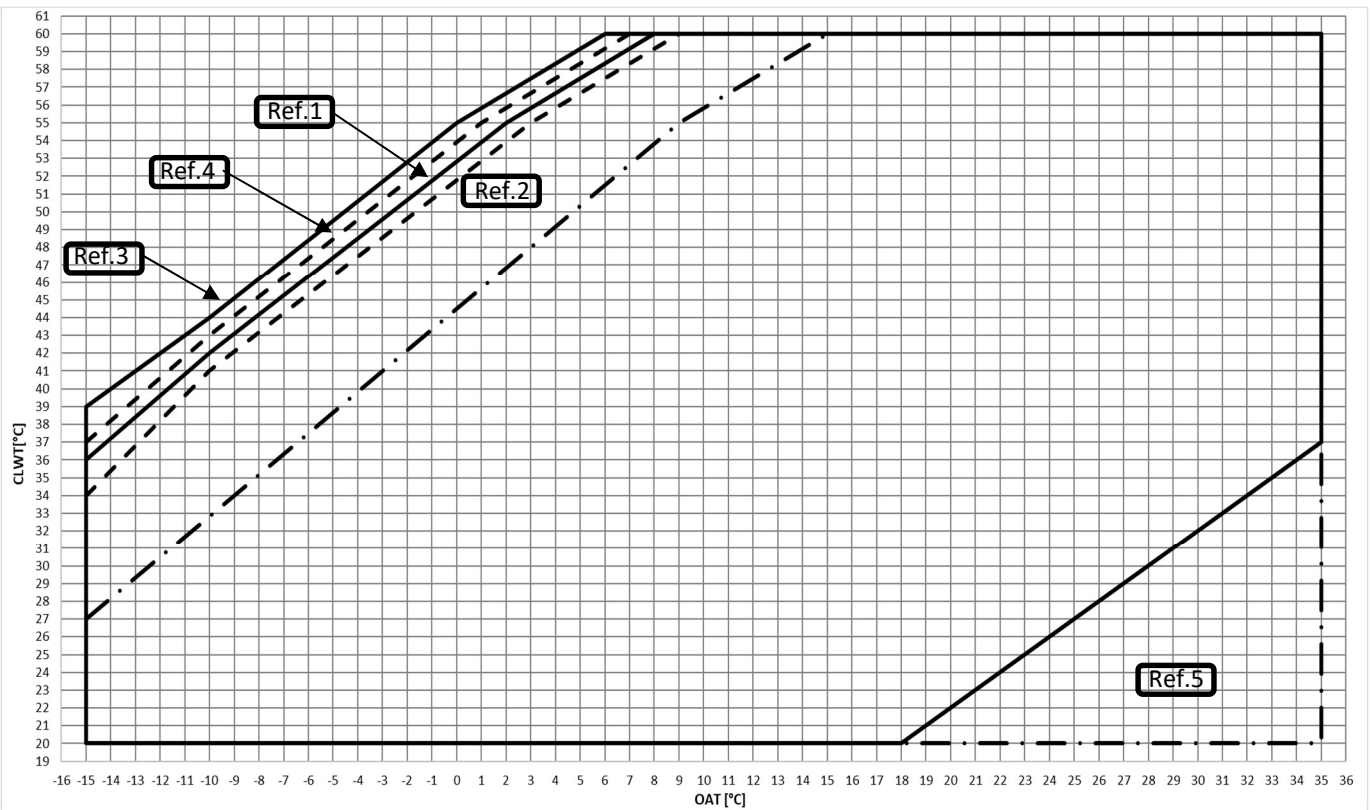

The above graph refers to the unit operating at full load. Unit may be able to operate outside the above envelope with compressors unloading. Please contact factory for further details.
 The above graphic represents a guideline about the operating limits of the range. Please refer to the latest Unit Selection Software (CSS) for real operating limits working conditions for each size.

EWYT~B-S – OP.204 - (SILVER SERIES) - Parallel and Double-V Coil - HEATING

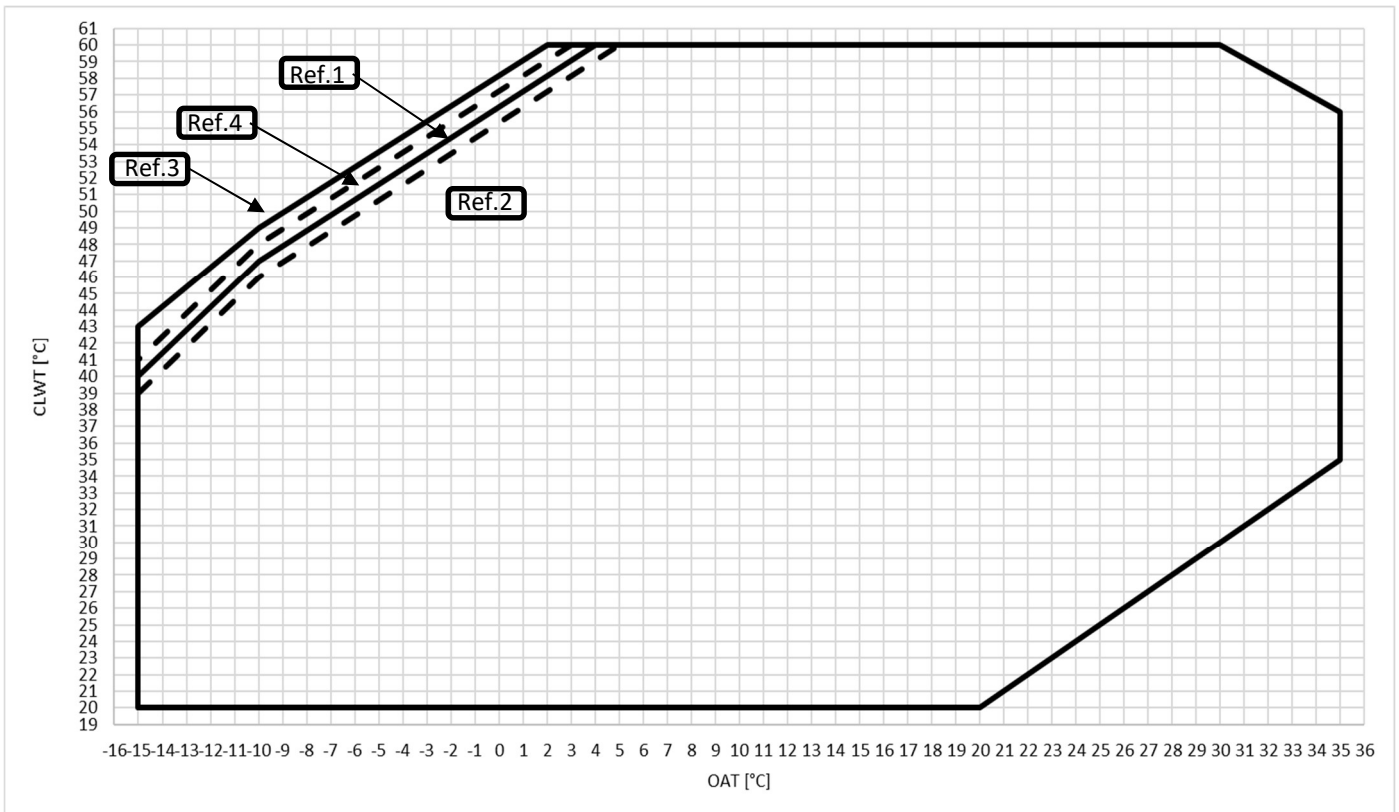

EWYT~B-X – OP.204 - (GOLD SERIES) - Parallel and Double-V Coil - HEATING

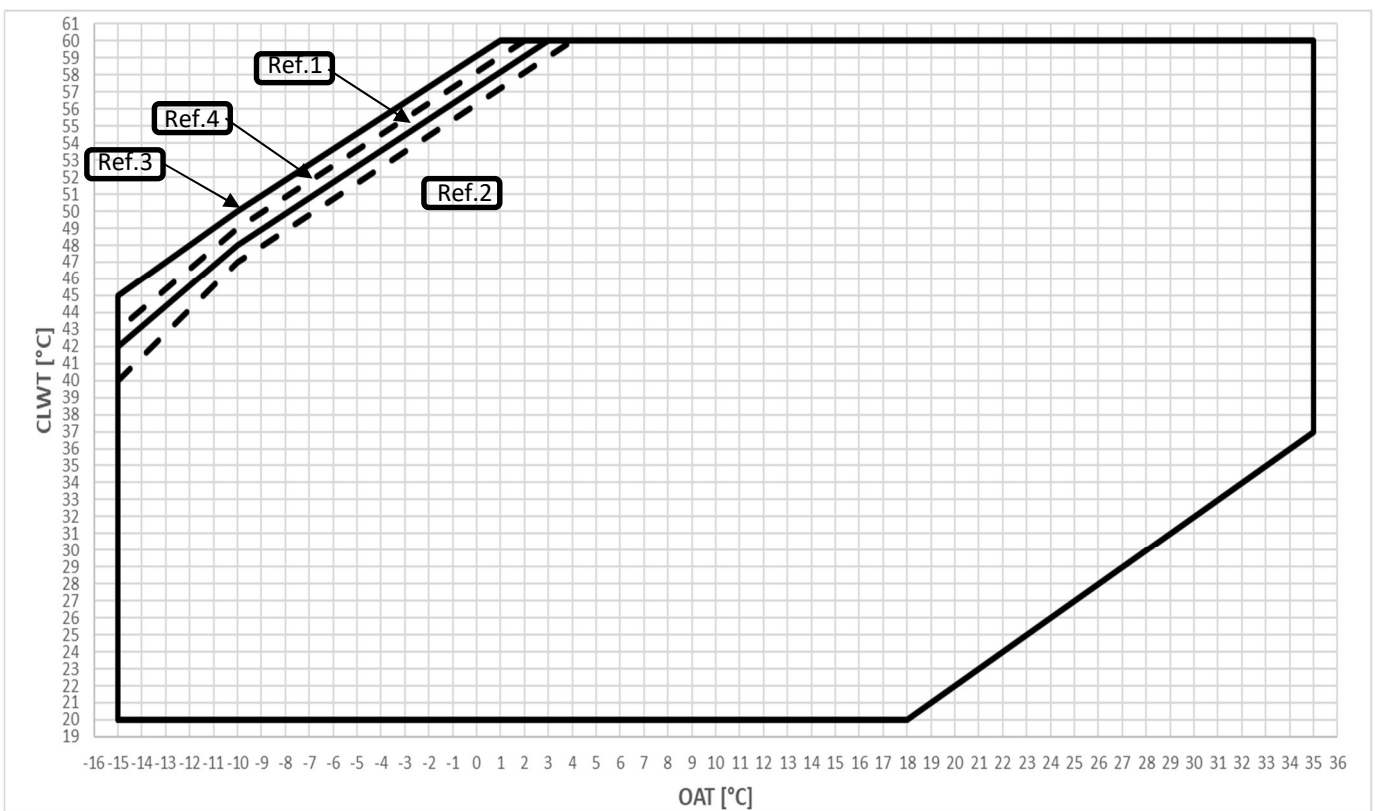

The above graph refers to the unit operating at full load. Unit may be able to operate outside the above envelope with compressors unloading. Please contact factory for further details.
 The above graphic represents a guideline about the operating limits of the range. Please refer to the latest Unit Selection Software (CSS) for real operating limits working conditions for each size.

EWYT~B-S (SILVER SERIES) – Parallel Coil - COOLING

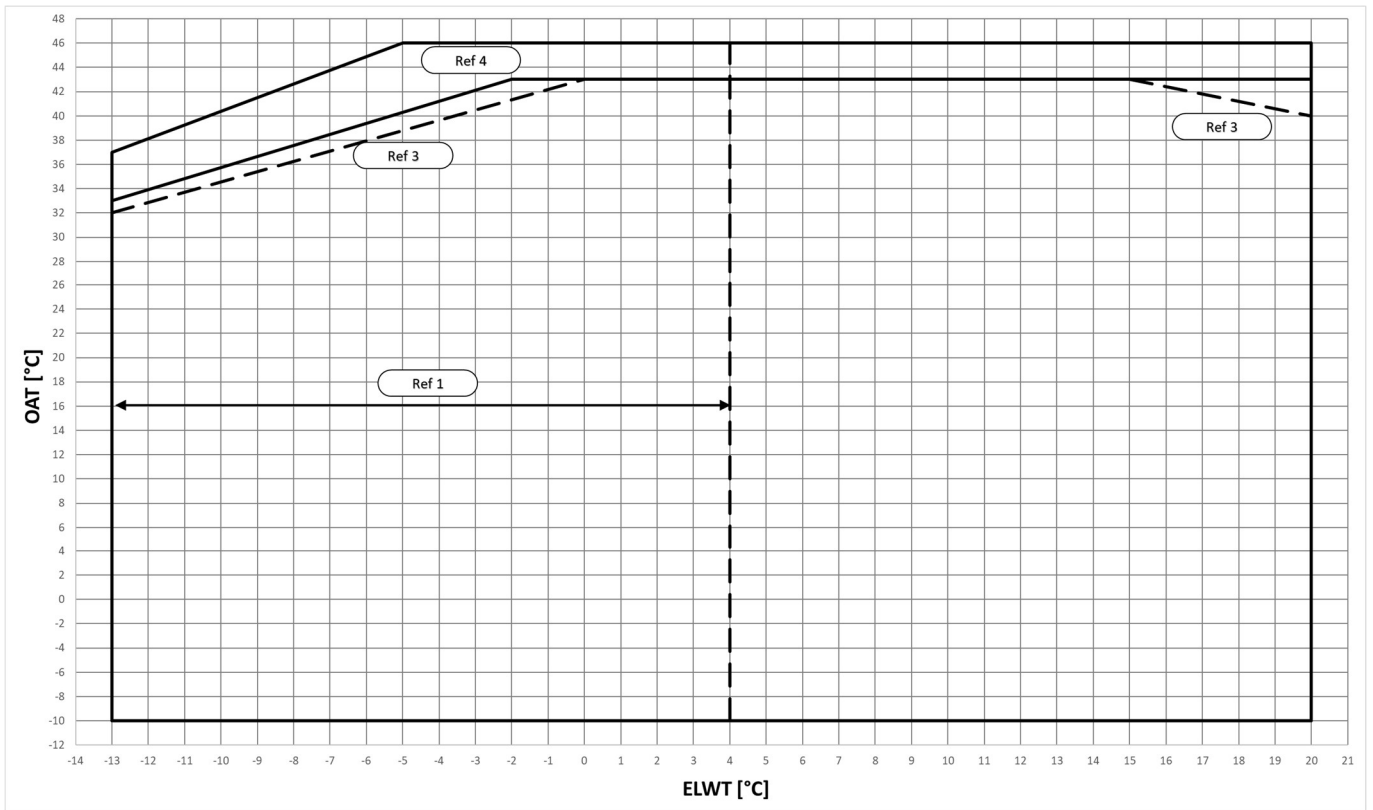

EWYT~B-X (GOLD SERIES) - Parallel Coil - COOLING

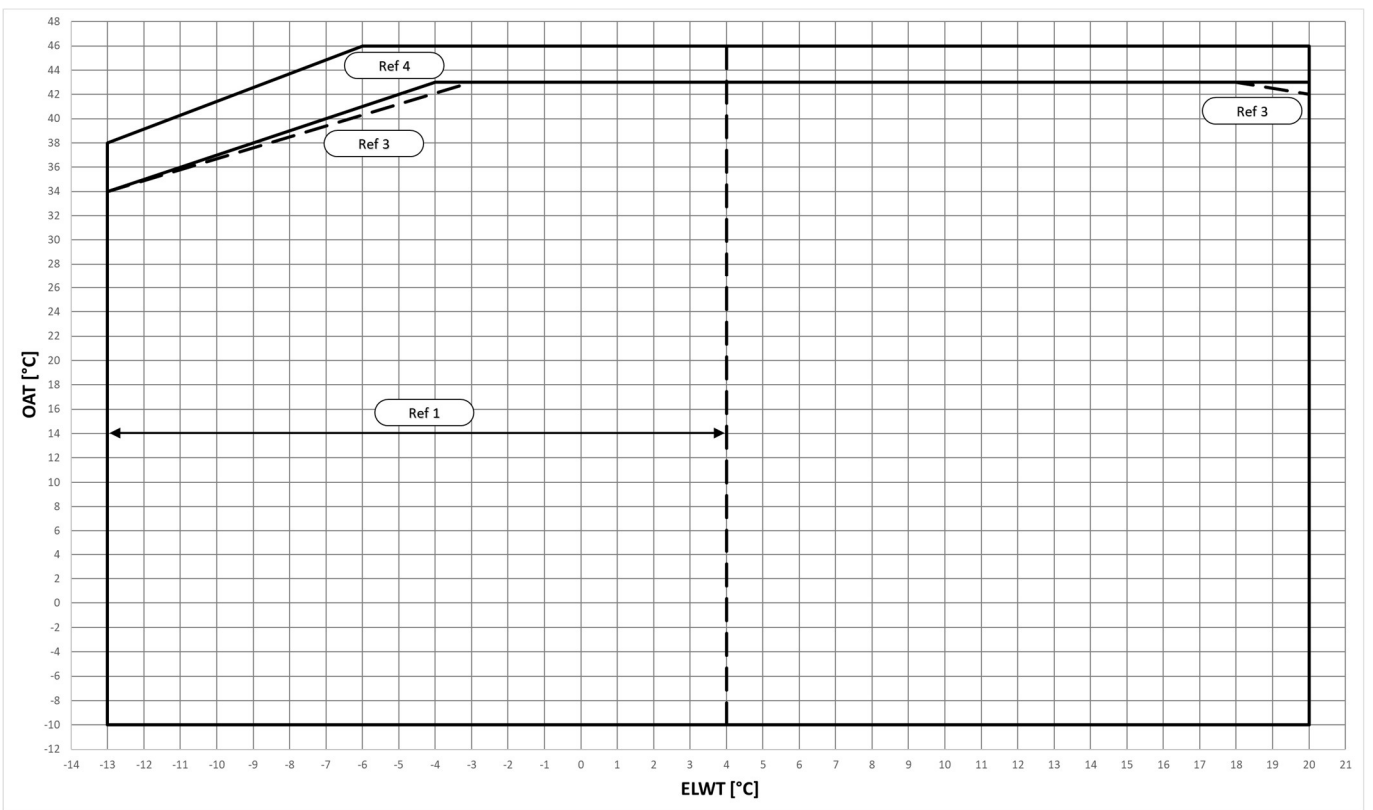

EWYT~B-S (SILVER SERIES) – Double V Coil - COOLING

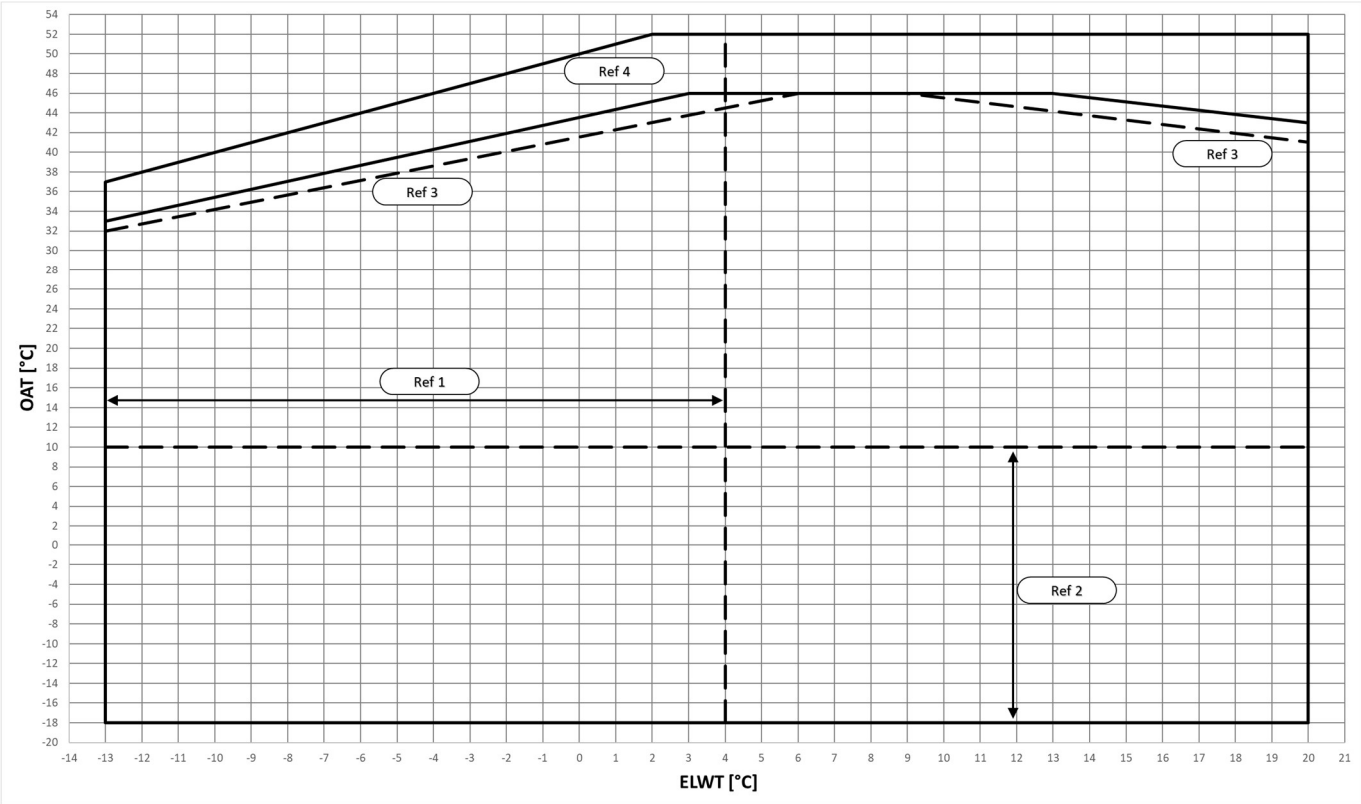

EWYT~B-X (GOLD SERIES) – Double V Coil - COOLING

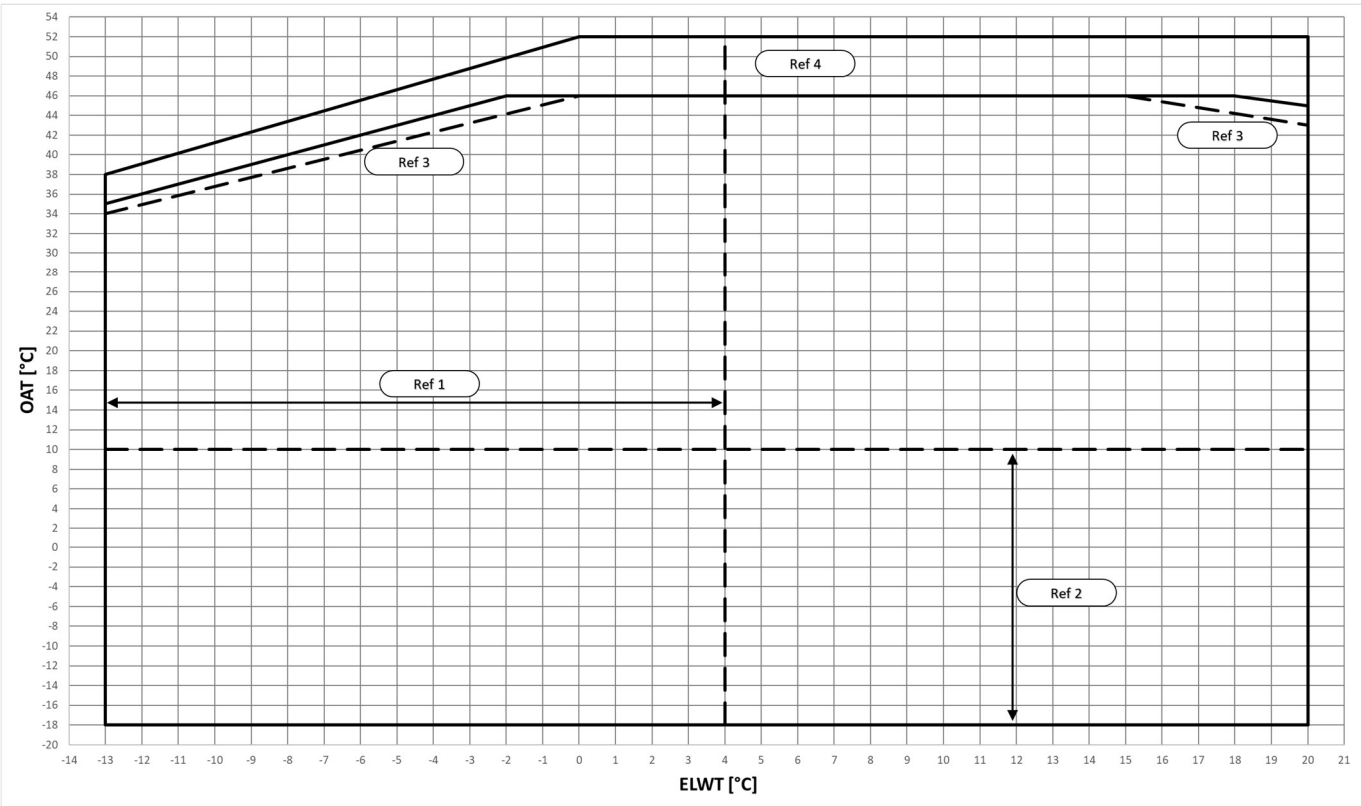

The above graphic represents a guideline about the operating limits of the range. Please refer to the latest Unit Selection Software (CSS) for real operating limits working conditions for each size.

Heating Envelope legend;

OAT	Outside ambient temperature
CLWT	Condenser leaving water temperature
Ref 1	Full load operation, "standard noise" configuration
Ref 2	Full load operation, "reduced noise" configuration
Ref 3	Partial load operation, "standard noise" configuration
Ref 4	Partial load operation, "reduced noise" configuration
Ref 5	Operation requiring the OP.205

Cooling Envelope legend;

OAT	Outside ambient temperature
ELWT	Evaporator leaving water temperature
Ref 1	Operation with ELWT <4 ° C requires option 08 (BRINE) and glycol
Ref 2	Operation at ambient temperatures <10 ° C requires option 99A (fan speed modulation) or option 42 (Speedroll)
Ref 3	Units with the "Reduced noise" configuration can increase the sound level in this area
Ref 4	Partial load operation; operation at full load may require option 142A-B-C (High ambient temperature kit)

Water heat exchanger - maximum/maximum water Δt

The minimum and maximum allowed Δt at full load conditions are respectively 2,5 °C and 10°C. Contact factory in case lower or higher Δt are required. Minimum and maximum Water Side Heat Exchanger flows are to be respected withing the Δt range above.

Water flow

The following tables indicate the minimum and maximum water flow allowed for each model. The minimum flow indicated correspond to the minimum flow allowed at minimum load for the unit. It is not intended as minimum flow allowed for unit full load operation. For minimum flow allowed (maximum deltaT) in full load operation refer to Selection Software. The below values are referred to pure water (in case of glycol mixture contact factory). Note: the performances are certified at standard conditions and with the unit operating with the nominal water flow.

Model	Min Flow [l/s]	Max Flow [l/s]	Model	Min Flow [l/s]	Max Flow [l/s]
EWYT085B-S-A1	2.5	12.5	EWYT085B-X-A1	3.4	17.0
EWYT105B-S-A1	2.5	12.5	EWYT115B-X-A1	3.4	17.0
EWYT135B-S-A1	2.5	12.5	EWYT135B-X-A1	3.4	17.0
EWYT175B-S-A1	2.5	12.5	EWYT175B-X-A1	4.6	22.9
EWYT215B-S-A1	3.4	17.0	EWYT215B-X-A1	4.6	22.9
EWYT205B-S-A2	3.4	17.0	EWYT215B-X-A2	7.6	31.2
EWYT235B-S-A2	3.4	17.0	EWYT235B-X-A2	7.6	31.2
EWYT255B-S-A2	4.1	19.9	EWYT265B-X-A2	7.6	31.2
EWYT300B-S-A2	4.1	19.9	EWYT310B-X-A2	7.6	31.2
EWYT340B-S-A2	5.4	26.4	EWYT350B-X-A2	7.6	31.2
EWYT390B-S-A2	5.4	26.4	EWYT400B-X-A2	7.6	31.2
EWYT430B-S-A2	5.4	26.4	EWYT440B-X-A2	10.4	51.2
EWYT490B-S-A2	6.7	31.2	EWYT500B-X-A2	10.4	51.2
EWYT540B-S-A2	6.7	31.2	EWYT560B-X-A2	10.9	53.7
EWYT590B-S-A2	8.2	41.2	EWYT600B-X-A2	10.9	53.7
EWYT630B-S-A2	8.2	41.2	EWYT630B-X-A2	10.9	53.7
			EWYT650B-X-A2	10.9	53.7

Minimum glycol percentage for low air ambient temperature to prevent freezing of the hydraulic circuit

AMBIENT T [°C]	-3	-8	-15	-20	AMBIENT T [°C]	-3	-8	-15	-20
ETHYLENE GLYCOL	10%	20%	30%	40%	PROPYLENE GLYCOL	10%	20%	30%	40%

The presence of glycol in the water system will affect unit performances. Refer to the selection software for details. All machine protection systems, such as antifreeze and low-pressure protection will need to be set in accordance to the type and percentage of the glycol and plant requirements.

Air heat exchanger - Altitude correction factors

ELEVATION ABOVE SEA LEVEL [m]	0	300	600	900	1200	1500	1800
BAROMETRIC PRESSURE [mbar]	1013	997	942	908	875	843	812
COOLING CAPACITY CORRECTION FACTOR	1	0,993	0,986	0,979	0,973	0,967	0,96
POWER INPUT CORRECTION FACTOR	1	1,005	1,009	1,015	1,021	1,026	1,031

Maximum operating altitude is 1800 m above sea level.
 Contact factory if the unit has to be installed 1000 m above the sea level.

Available fan static pressure correction factors

COOLING				
EXTERNAL STATIC PRESSURE [Pa]	0	10	20	30
COOLING CAPACITY CORRECTION FACTOR	1	1	0.99	0.99
UNIT PI CORRECTION FACTOR	1	1.01	1.02	1.02
REDUCTION OF MAX OPERATING AMBIENT TEMPERATURE [°C]	0	-0.3	-0.5	-1

HEATING				
EXTERNAL STATIC PRESSURE [Pa]	0	10	20	30
HEATING CAPACITY CORRECTION FACTOR	1	0.991	0.972	0.96
UNIT PI CORRECTION FACTOR	1	0.998	0.995	0.994
INCREASE OF MIN OPERATING AMBIENT TEMPERATURE [°C]	0	0.5	0.8	1

The above table is valid for SILVER and GOLD series with standard and VFD driven fans. Application with more than 30 Pa of external static pressure are not recommended. In case where external static pressure over 30 Pa is required special high ESP fans are required.

Partial Heat recovery Units may be optionally equipped with heat recovery system. This system is made by a water -cooled heat exchanger located on the compressors discharge pipe and a dedicated management of condensing pressure.

To guarantee compressor operation within its envelope, units with heat recovery cannot operate with water temperature of the heat recovery water lower than 25°C.

It is a responsibility of plant designer and unit installer to guarantee the respect of this value (e.g. using recirculating bypass valve).

Plant water content The cooled water distribution circuits should have minimum water content to avoid excessive compressors start and stop. In fact, each time the compressor starts up, an excessive quantity of oil goes from the compressor sump and simultaneously there is a rise in the temperature of the compressor motor’s stator due to the inrush current during the start – up. To prevent damage to the compressors, have been envisaged the application of a device to limit frequent stops and restarts.

During the span of one hour there will be no more than 10 starts of the compressor. The plant side should therefore ensure that the overall water content allows a more constant functioning of the unit and consequently greater environmental comfort.

The calculation of the water content should also consider the plant’s design parameters.

As a general indication the water content should not be less than 5 lt/kW on single circuit units and 2,5l/kW on the twin circuit units.

Note: The indication is intended as a general guideline and not intended to substitute the evaluation made by qualified technical personnel or by HVAC engineers, For more detailed analysis is better to consider the use of other more detailed approach.

Water quality Before putting the unit into operation, clean the water circuit. Dirt, scales, corrosion debris and other material can accumulate inside the heat exchanger and reduce its heat exchanging capacity. Pressure drop can increase as well, thus reducing water flow. Proper water treatment therefore reduces the risk of corrosion, erosion, scaling, etc. The most appropriate water treatment must be determined locally, according to the type of system and water characteristics. The manufacturer is not responsible for damage to or malfunctioning of equipment caused by failure to treat water or by improperly treated water. Plant water must respect the following table;

DAE Water quality requirements	BPHE
Ph (25 °C)	7.5 – 9.0
Electrical conductivity [$\mu\text{S}/\text{cm}$] (25°C)	< 500
Chloride ion [$\text{mg Cl}^- / \text{l}$]	< 70 (HP ¹) < 300 (CO ²)
Sulphate ion [$\text{mg SO}_4^{2-} / \text{l}$]	< 100
Alkalinity [$\text{mg CaCO}_3 / \text{l}$]	< 200
Total Hardness [$\text{mg CaCO}_3 / \text{l}$]	75 ÷ 150
Iron [$\text{mg Fe} / \text{l}$]	< 0.2
Ammonium ion [$\text{mg NH}_4^+ / \text{l}$]	< 0.5
Silica [$\text{mg SiO}_2 / \text{l}$]	-
Chlorine molecular ($\text{mg Cl}_2/\text{l}$)	< 0.5

Note: 1. Heat Pump
2. Cooling Only

EWYT~B- PARALLEL COIL – Single pump low lift

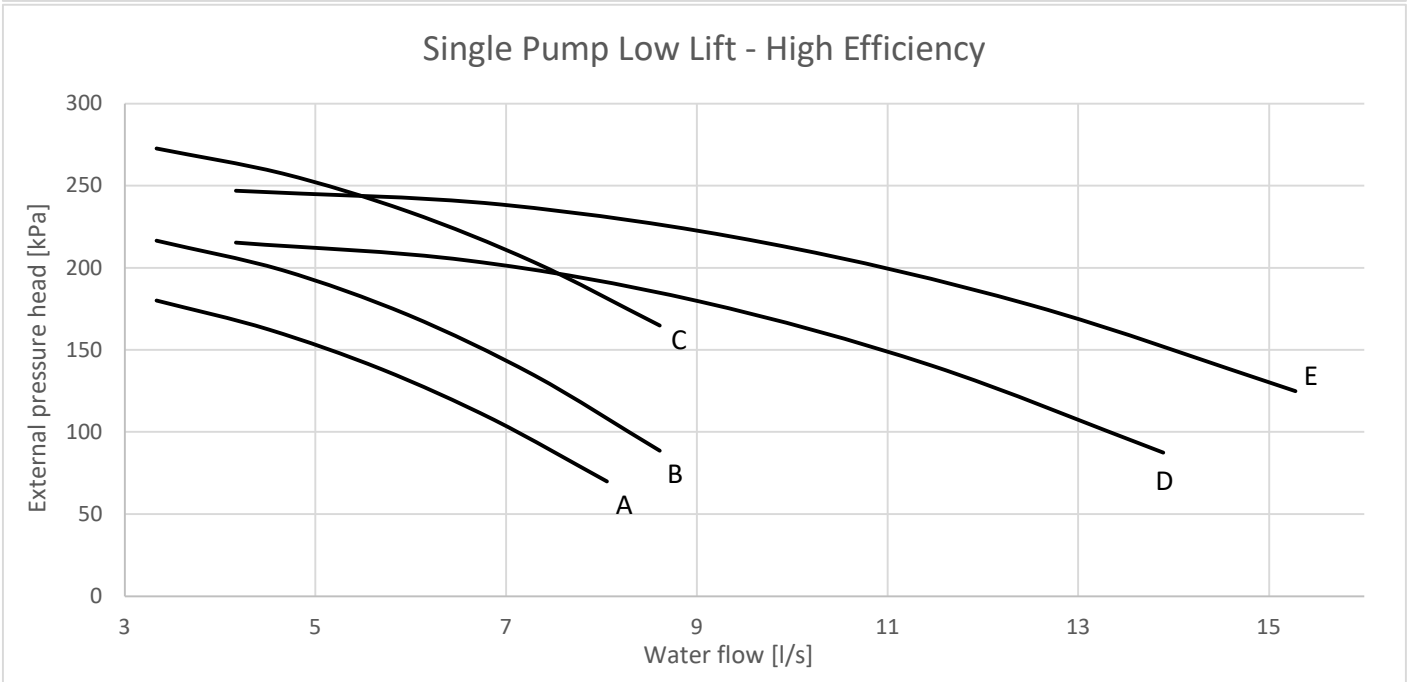
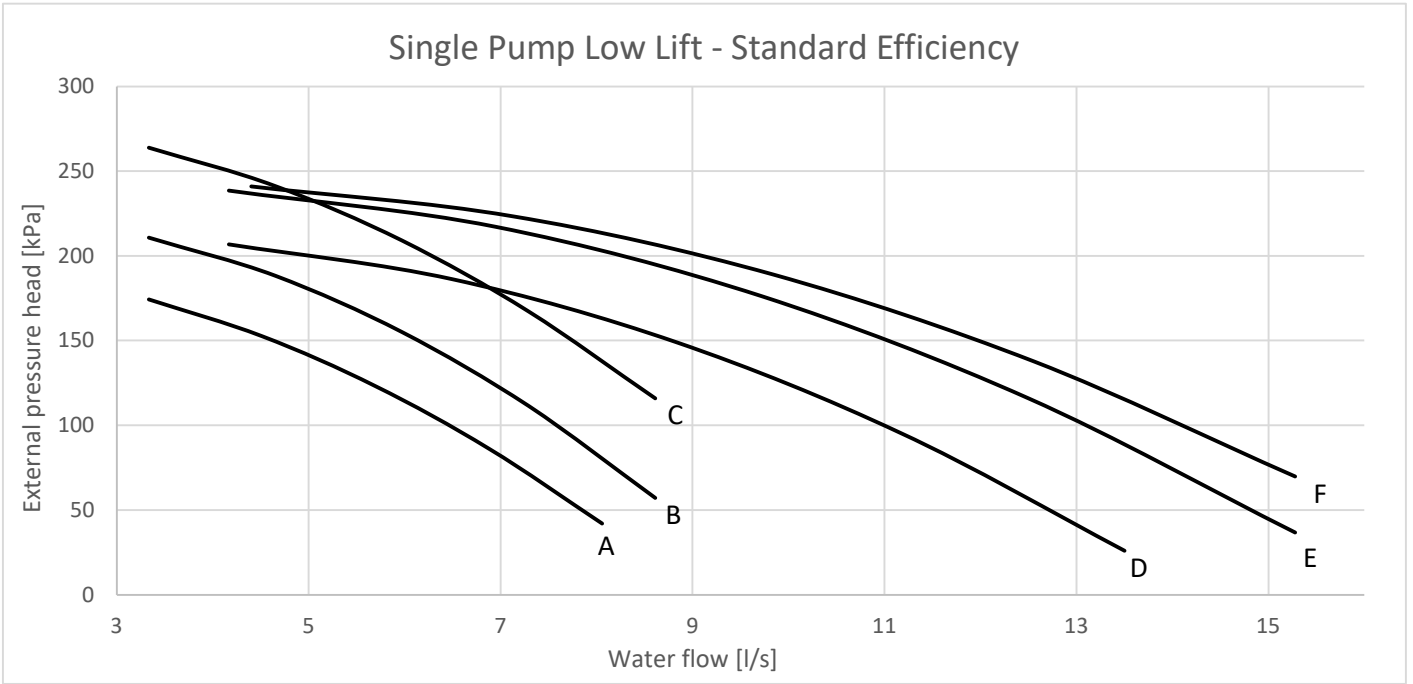

*External pressure head is intended as the static head provided by the pump minus the evaporator pressure losses at Eurovent conditions

Model	Pump curve	Model	Pump curve
EWYT085B-SS(L)(R)A1	A	EWYT085B-XS(L)(R)A1	A
EWYT105B-SS(L)(R)A1	A	EWYT115B-XS(L)(R)A1	A
EWYT135B-SS(L)(R)A1	B	EWYT135B-XS(L)(R)A1	B
EWYT175B-SS(L)(R)A1	C	EWYT175B-XS(L)(R)A1	C
EWYT215B-SS(L)(R)A1	F	EWYT215B-XS(L)(R)A1	E
EWYT205B-SS(L)(R)A2	D	EWYT215B-XS(L)(R)A2	D
EWYT235B-SS(L)(R)A2	E	EWYT235B-XS(L)(R)A2	D
EWYT255B-SS(L)(R)A2	F	EWYT265B-XS(L)(R)A2	E

EWYT~B- DOUBLE V COIL – Single pump low lift

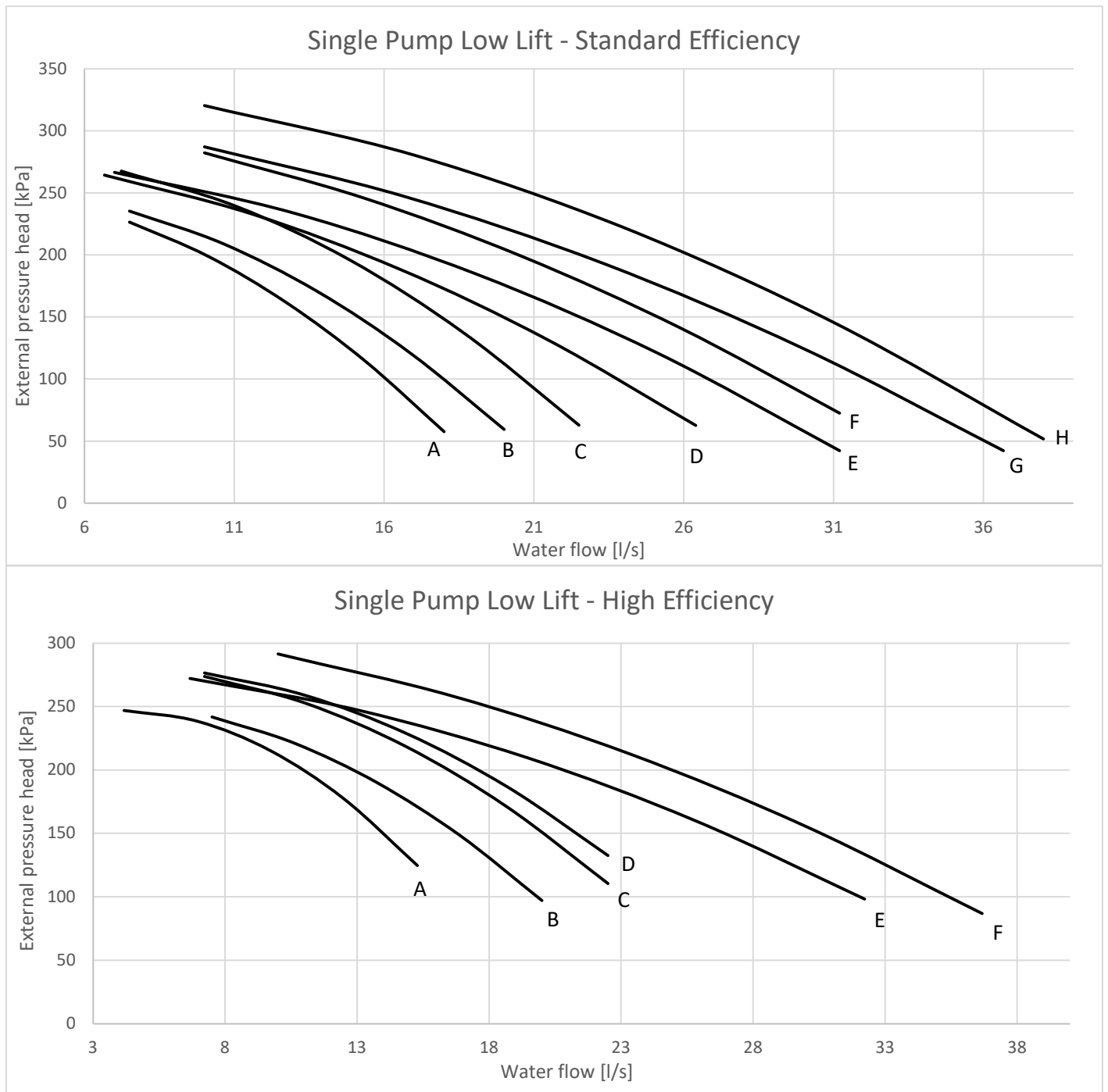

*External pressure head is intended as the static head provided by the pump minus the evaporator pressure losses at Eurovent conditions

Model	Pump curve	Model	Pump curve
EWYT300B-SS(L)(R)A2	A	EWYT310B-XS(L)(R)A2	A
EWYT340B-SS(L)(R)A2	B	EWYT350B-XS(L)(R)A2	B
EWYT390B-SS(L)(R)A2	C	EWYT400B-XS(L)(R)A2	C
EWYT430B-SS(L)(R)A2	D	EWYT440B-XS(L)(R)A2	D
EWYT490B-SS(L)(R)A2	E	EWYT500B-XS(L)(R)A2	E
EWYT540B-SS(L)(R)A2	F	EWYT560B-XS(L)(R)A2	E
EWYT590B-SS(L)(R)A2	G	EWYT600B-XS(L)(R)A2	E
EWYT630B-SS(L)(R)A2	H	EWYT630B-XS(L)(R)A2	F
		EWYT650B-XS(L)(R)A2	F

EWYT~B- PARALLEL COIL – Single pump high lift

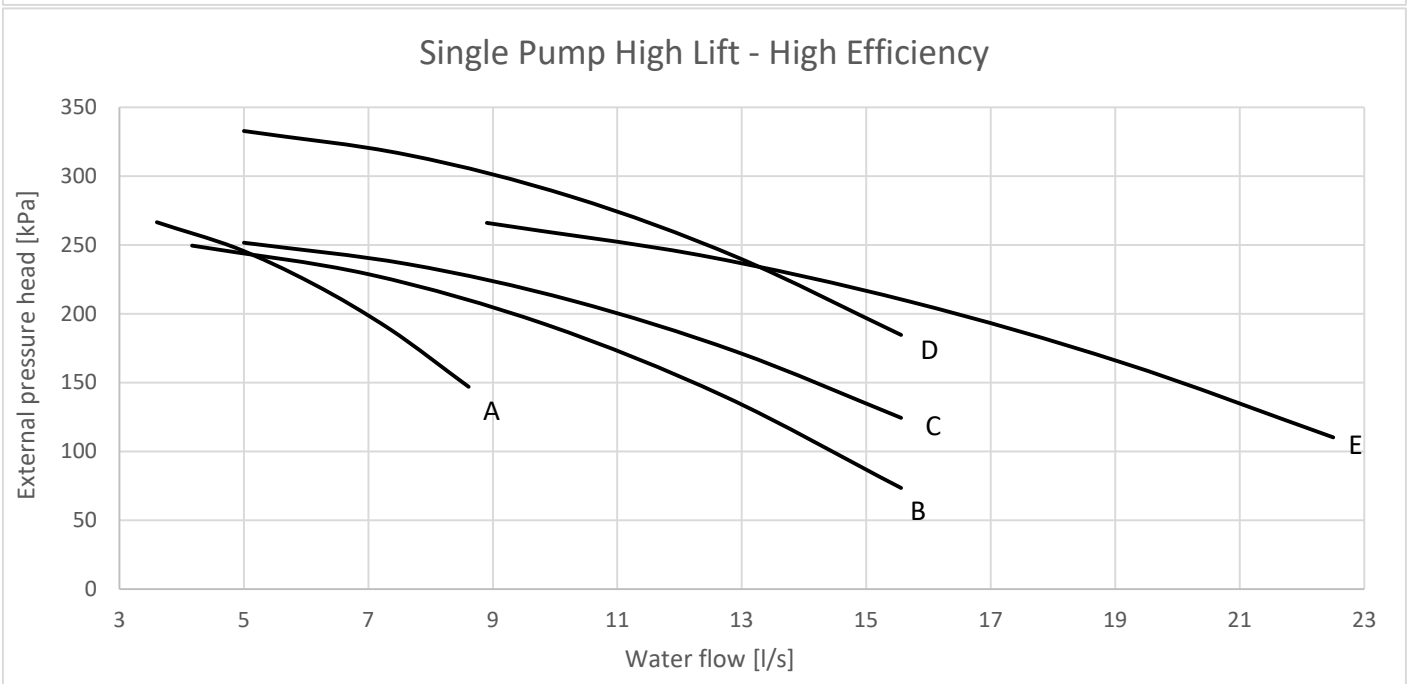
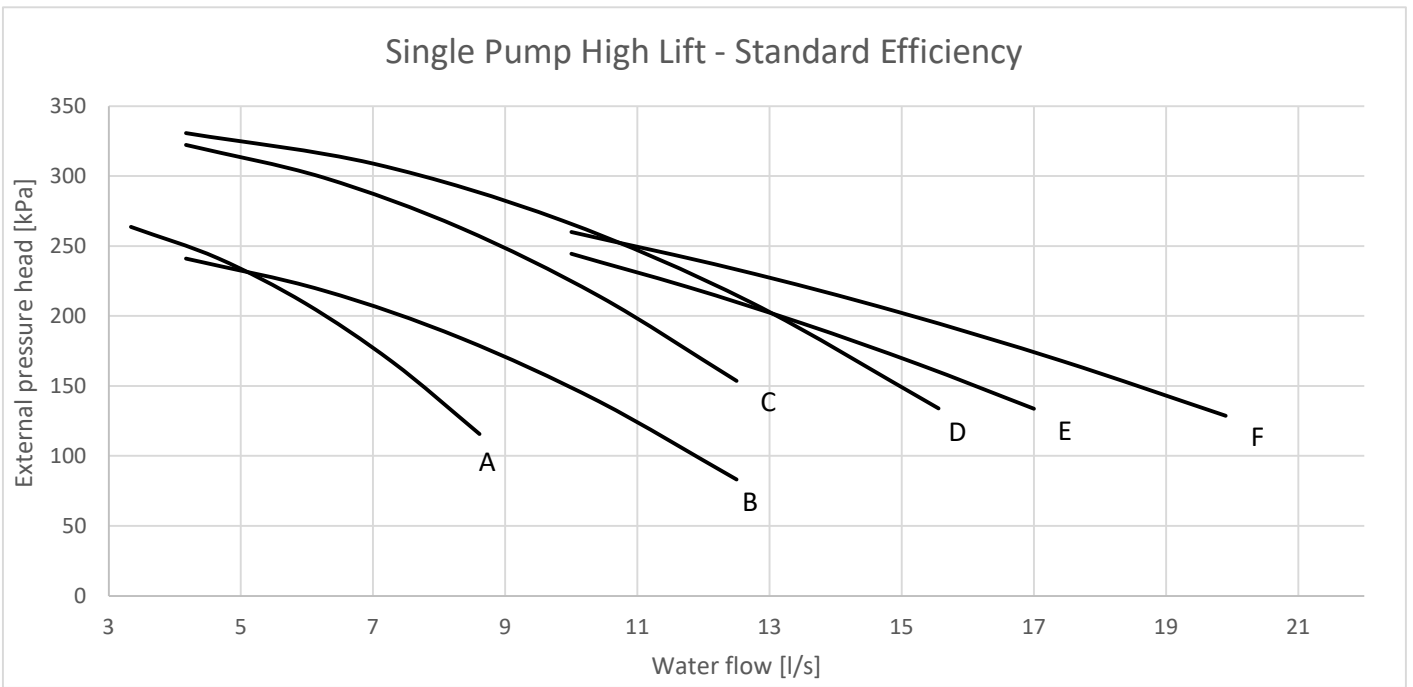

*External pressure head is intended as the static head provided by the pump minus the evaporator pressure losses at Eurovent conditions

Model	Pump curve	Model	Pump curve
EWYT085B-SS(L)(R)A1	A	EWYT085B-XS(L)(R)A1	A
EWYT105B-SS(L)(R)A1	A	EWYT115B-XS(L)(R)A1	A
EWYT135B-SS(L)(R)A1	B	EWYT135B-XS(L)(R)A1	B
EWYT175B-SS(L)(R)A1	C	EWYT175B-XS(L)(R)A1	C
EWYT215B-SS(L)(R)A1	D	EWYT215B-XS(L)(R)A1	D
EWYT205B-SS(L)(R)A2	E	EWYT215B-XS(L)(R)A2	E
EWYT235B-SS(L)(R)A2	E	EWYT235B-XS(L)(R)A2	E
EWYT255B-SS(L)(R)A2	F	EWYT265B-XS(L)(R)A2	E

EWYT~B- DOUBLE V COIL – Single pump high lift

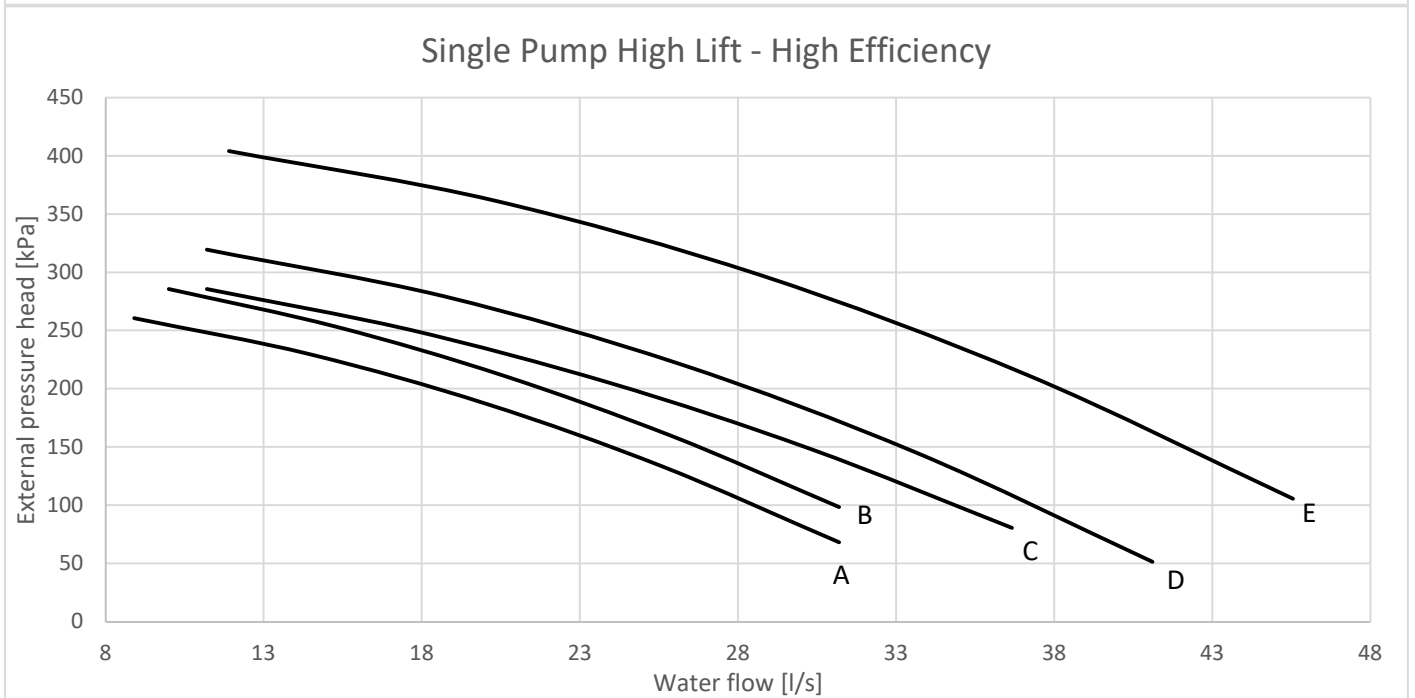
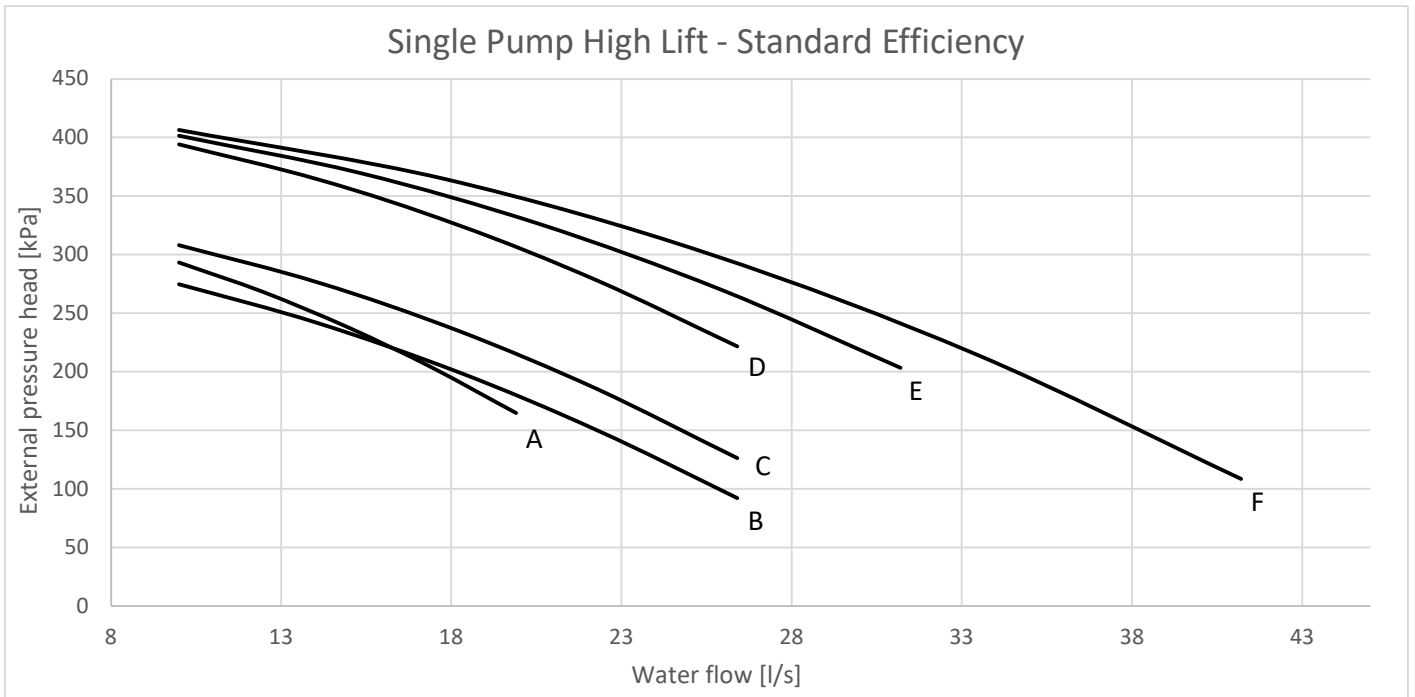

*External pressure head is intended as the static head provided by the pump minus the evaporator pressure losses at Eurovent conditions

Model	Pump curve	Model	Pump curve
EWYT300B-SS(L)(R)A2	A	EWYT310B-XS(L)(R)A2	A
EWYT340B-SS(L)(R)A2	B	EWYT350B-XS(L)(R)A2	B
EWYT390B-SS(L)(R)A2	C	EWYT400B-XS(L)(R)A2	B
EWYT430B-SS(L)(R)A2	D	EWYT440B-XS(L)(R)A2	C
EWYT490B-SS(L)(R)A2	E	EWYT500B-XS(L)(R)A2	D
EWYT540B-SS(L)(R)A2	E	EWYT560B-XS(L)(R)A2	D
EWYT590B-SS(L)(R)A2	F	EWYT600B-XS(L)(R)A2	E
EWYT630B-SS(L)(R)A2	F	EWYT630B-XS(L)(R)A2	E
		EWYT650B-XS(L)(R)A2	E

EWYT~B- PARALLEL COIL – Double pump low lift

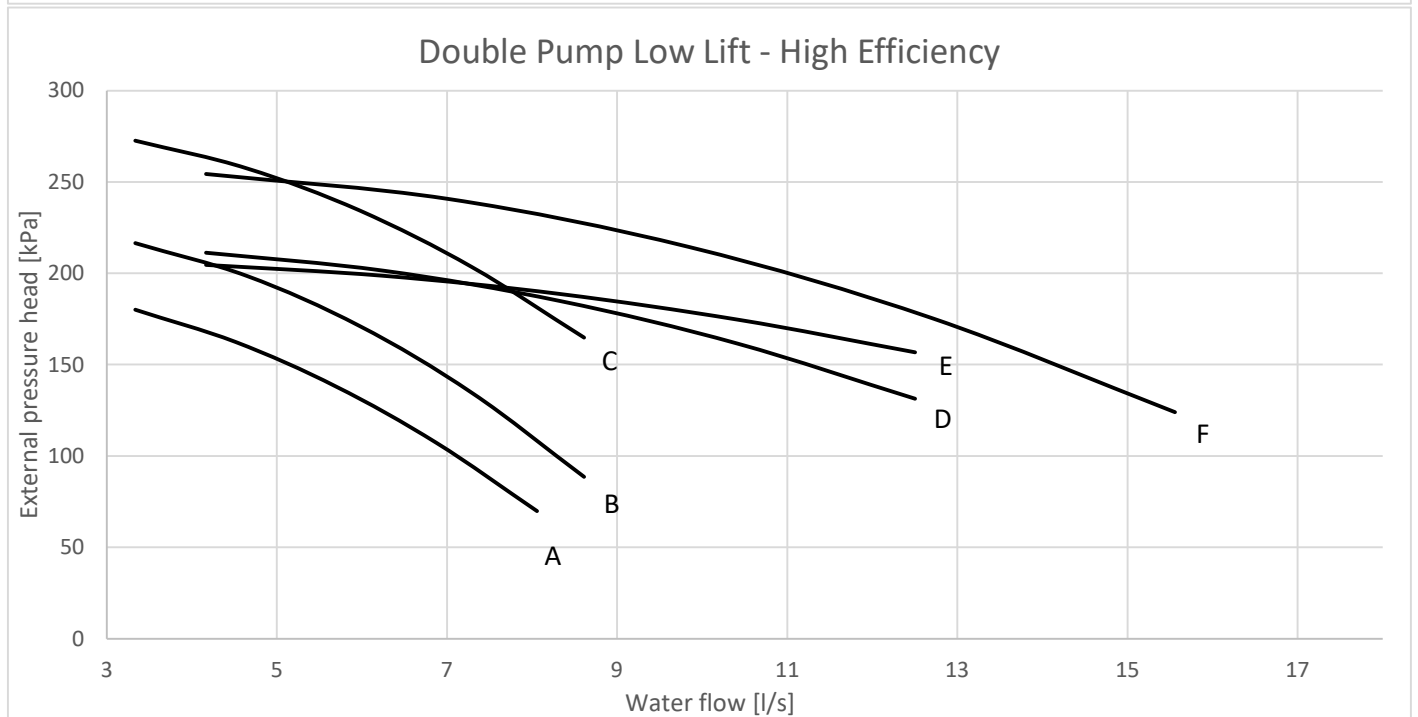
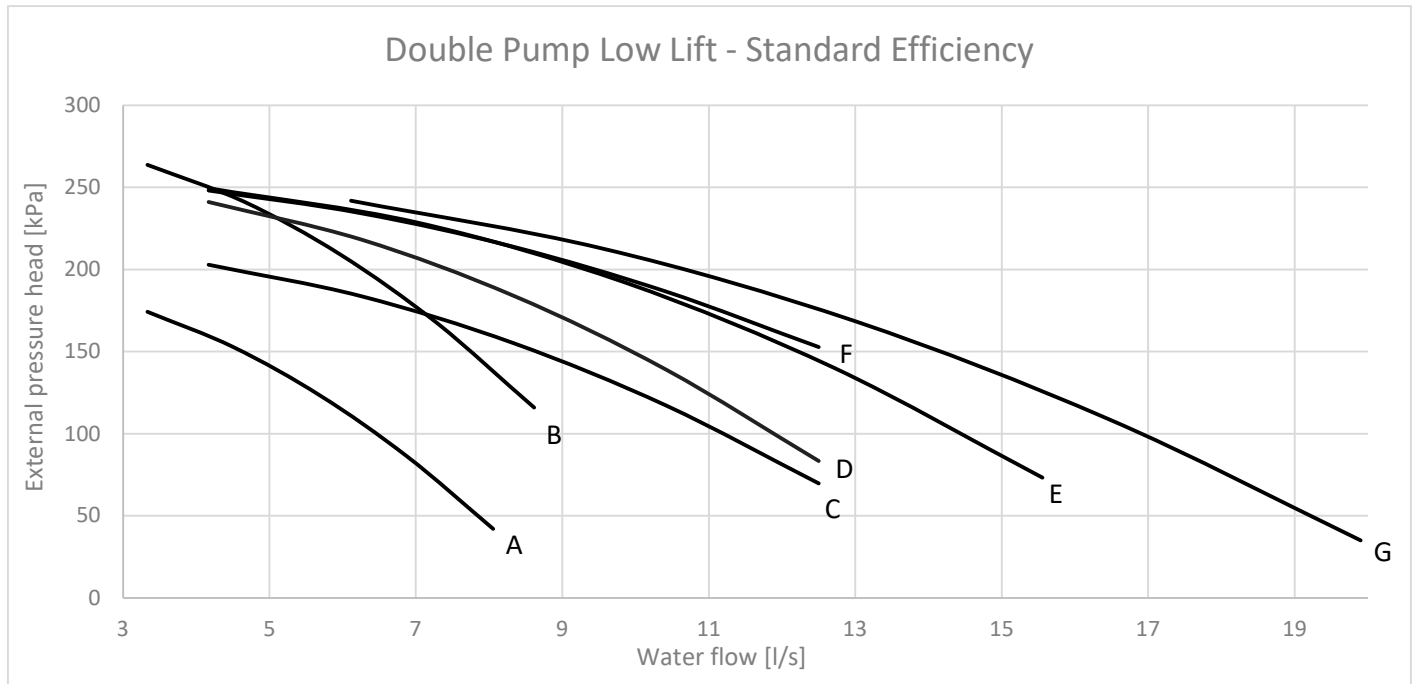

*External pressure head is intended as the static head provided by the pump minus the evaporator pressure losses at Eurovent conditions

Model	Pump curve	Model	Pump curve
EWYT085B-SS(L)(R)A1	A	EWYT085B-XS(L)(R)A1	A
EWYT105B-SS(L)(R)A1	A	EWYT115B-XS(L)(R)A1	A
EWYT135B-SS(L)(R)A1	B	EWYT135B-XS(L)(R)A1	B
EWYT175B-SS(L)(R)A1	D	EWYT175B-XS(L)(R)A1	C
EWYT215B-SS(L)(R)A1	E	EWYT215B-XS(L)(R)A1	F
EWYT205B-SS(L)(R)A2	C	EWYT215B-XS(L)(R)A2	D
EWYT235B-SS(L)(R)A2	F	EWYT235B-XS(L)(R)A2	E
EWYT255B-SS(L)(R)A2	G	EWYT265B-XS(L)(R)A2	E

EWYT~B- DOUBLE V COIL – Double pump low lift

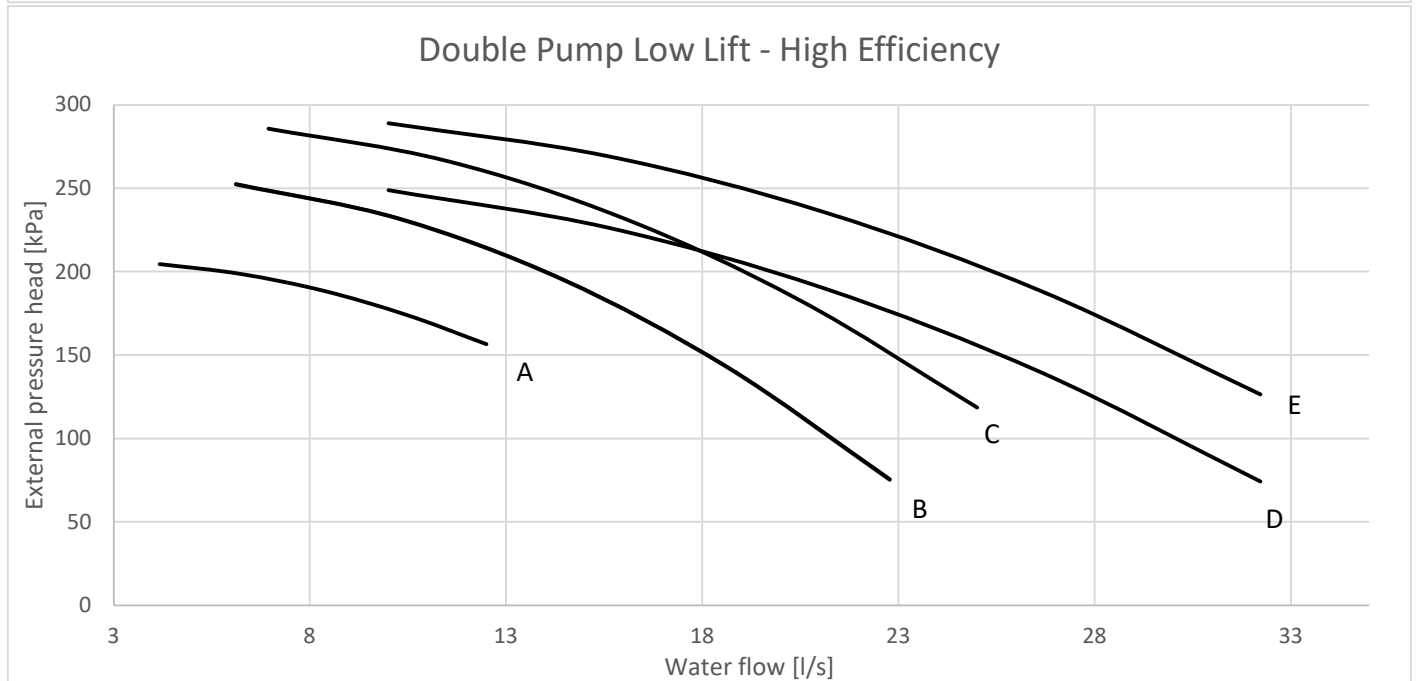
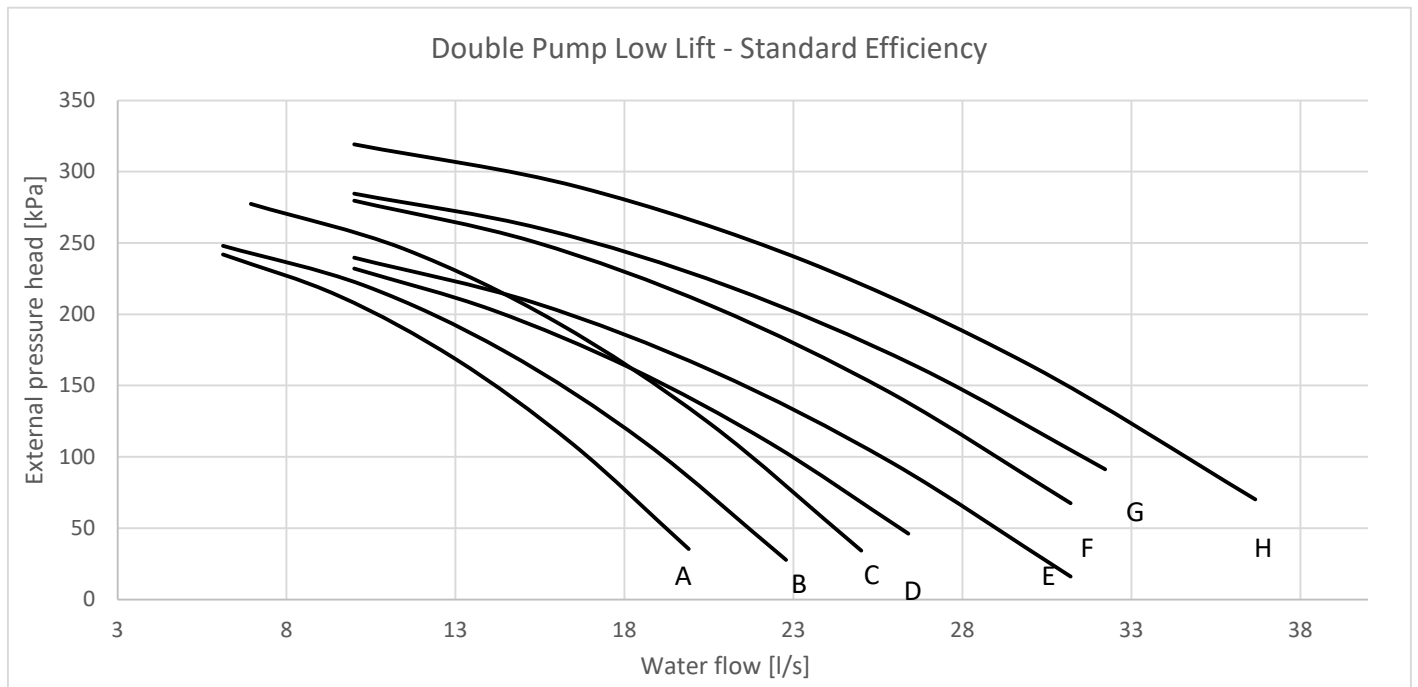

*External pressure head is intended as the static head provided by the pump minus the evaporator pressure losses at Eurovent conditions

Model	Pump curve	Model	Pump curve
EWYT300B-SS(L)(R)A2	A	EWYT310B-XS(L)(R)A2	A
EWYT340B-SS(L)(R)A2	B	EWYT350B-XS(L)(R)A2	B
EWYT390B-SS(L)(R)A2	C	EWYT400B-XS(L)(R)A2	B
EWYT430B-SS(L)(R)A2	D	EWYT440B-XS(L)(R)A2	C
EWYT490B-SS(L)(R)A2	E	EWYT500B-XS(L)(R)A2	C
EWYT540B-SS(L)(R)A2	F	EWYT560B-XS(L)(R)A2	D
EWYT590B-SS(L)(R)A2	G	EWYT600B-XS(L)(R)A2	E
EWYT630B-SS(L)(R)A2	H	EWYT630B-XS(L)(R)A2	E
		EWYT650B-XS(L)(R)A2	E

EWYT~B- PARALLEL COIL – Double pump high lift

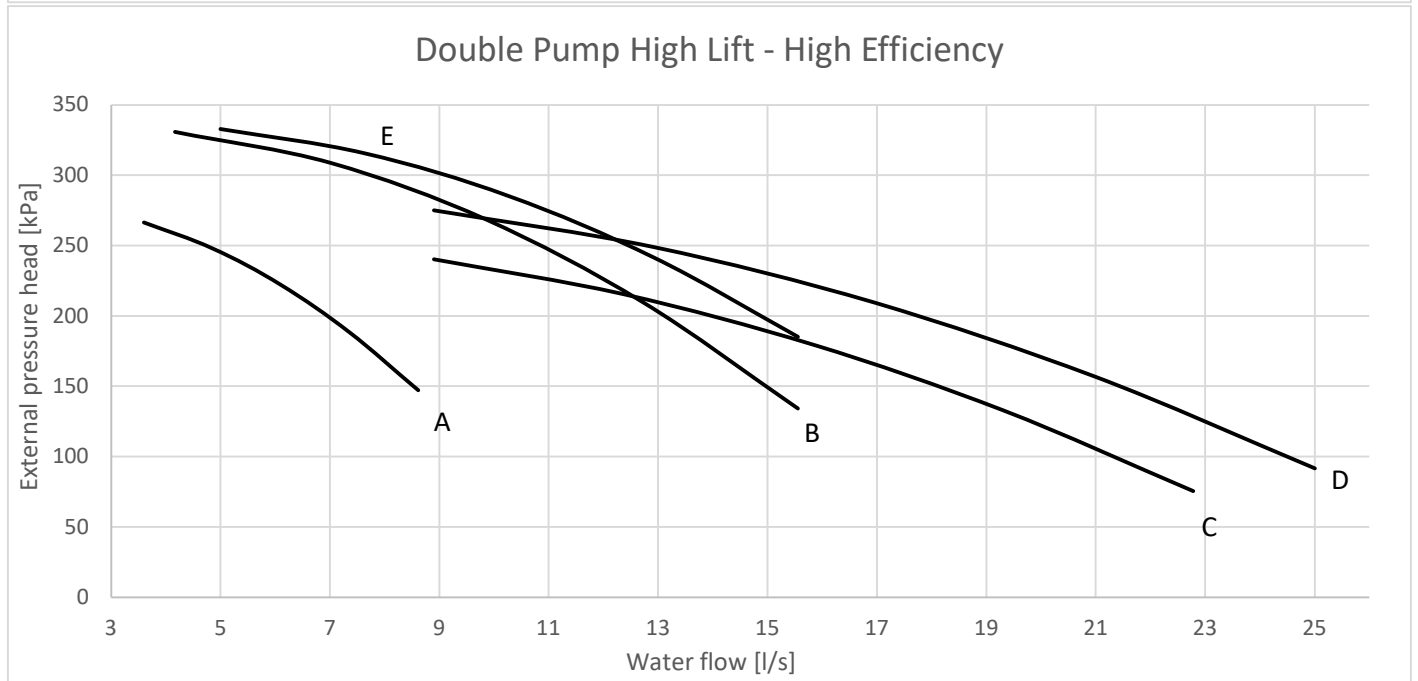
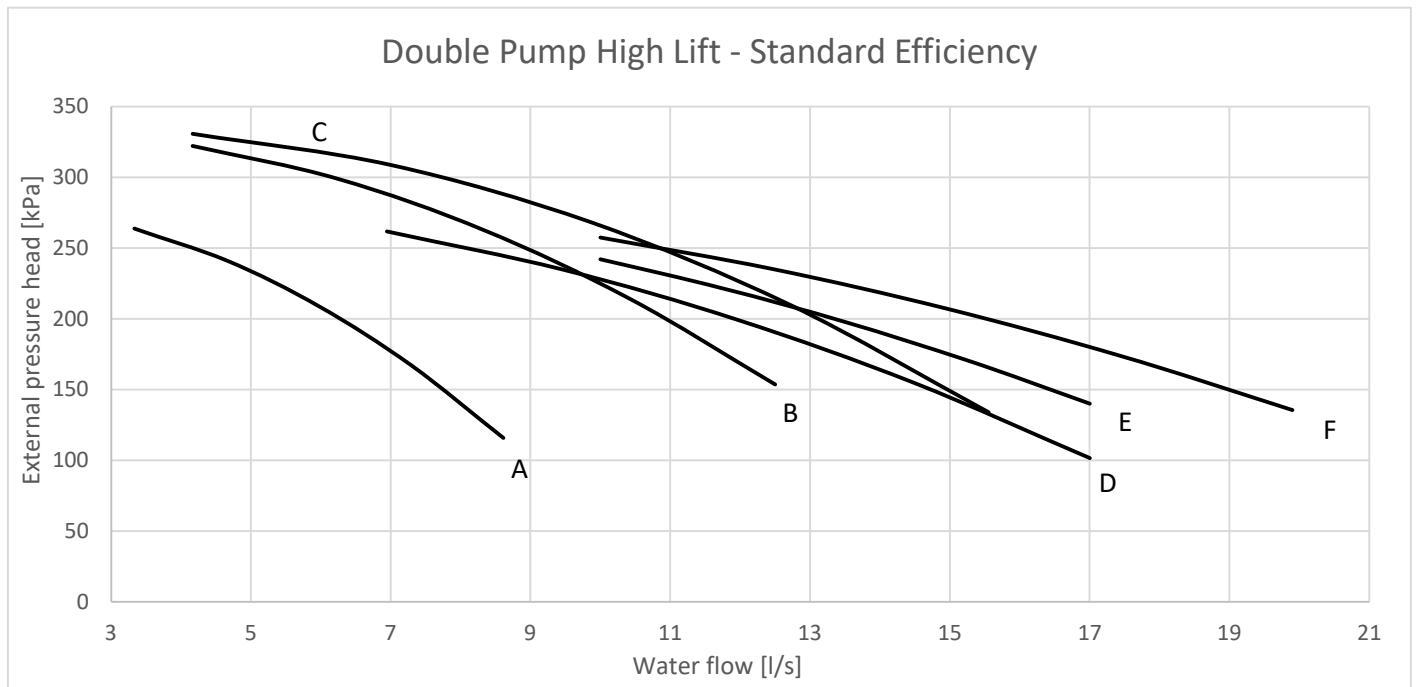

*External pressure head is intended as the static head provided by the pump minus the evaporator pressure losses at Eurovent conditions

Model	Pump curve	Model	Pump curve
EWYT085B-SS(L)(R)A1	A	EWYT085B-XS(L)(R)A1	A
EWYT105B-SS(L)(R)A1	A	EWYT115B-XS(L)(R)A1	A
EWYT135B-SS(L)(R)A1	B	EWYT135B-XS(L)(R)A1	B
EWYT175B-SS(L)(R)A1	B	EWYT175B-XS(L)(R)A1	E
EWYT215B-SS(L)(R)A1	C	EWYT215B-XS(L)(R)A1	E
EWYT205B-SS(L)(R)A2	D	EWYT215B-XS(L)(R)A2	C
EWYT235B-SS(L)(R)A2	E	EWYT235B-XS(L)(R)A2	C
EWYT255B-SS(L)(R)A2	F	EWYT265B-XS(L)(R)A2	D

EWYT~B- DOUBLE V COIL – Double pump high lift

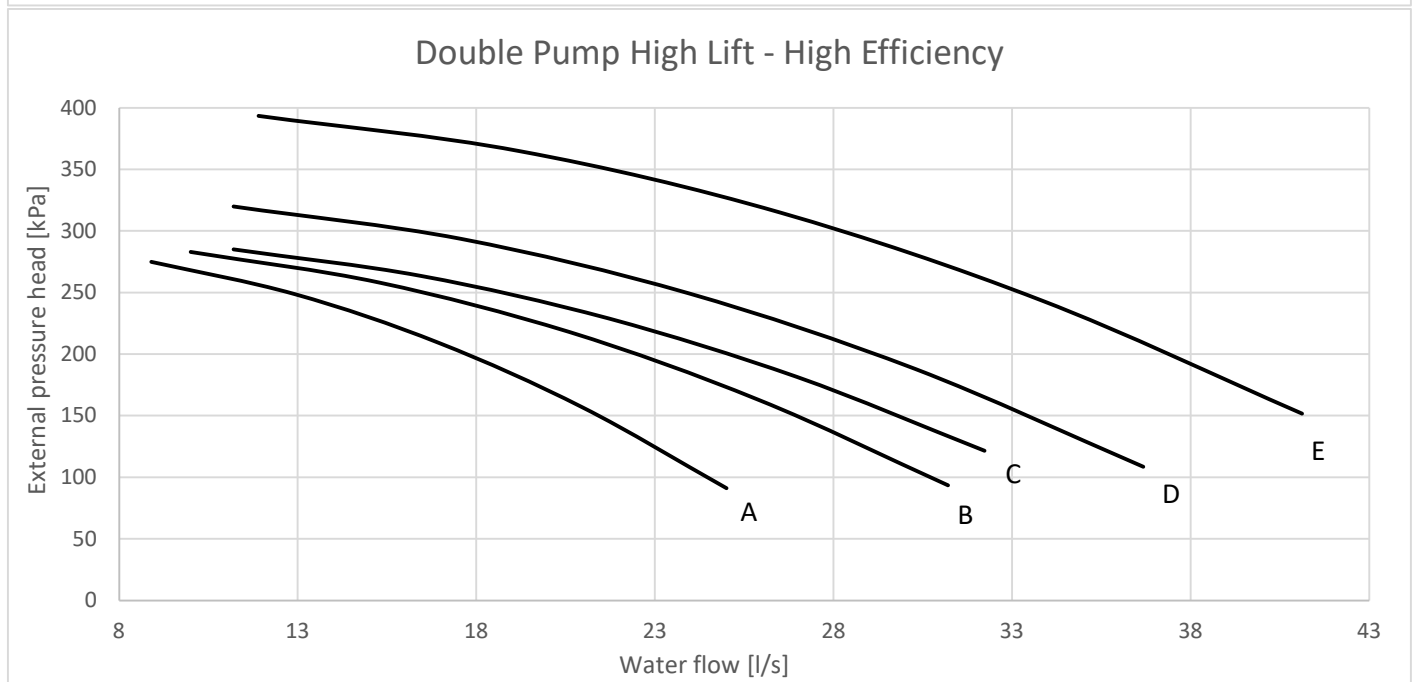
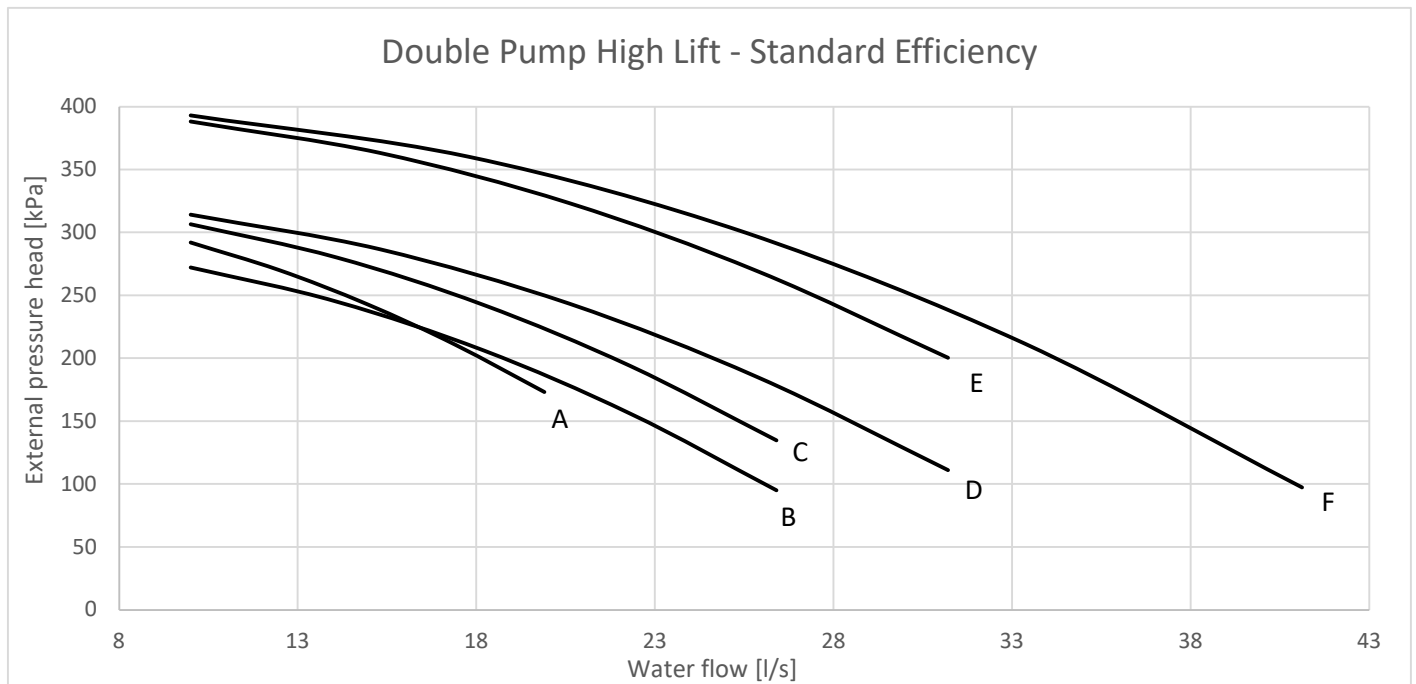

*External pressure head is intended as the static head provided by the pump minus the evaporator pressure losses at Eurovent conditions

Model	Pump curve	Model	Pump curve
EWYT300B-SS(L)(R)A2	A	EWYT310B-XS(L)(R)A2	A
EWYT340B-SS(L)(R)A2	B	EWYT350B-XS(L)(R)A2	B
EWYT390B-SS(L)(R)A2	C	EWYT400B-XS(L)(R)A2	B
EWYT430B-SS(L)(R)A2	C	EWYT440B-XS(L)(R)A2	C
EWYT490B-SS(L)(R)A2	D	EWYT500B-XS(L)(R)A2	D
EWYT540B-SS(L)(R)A2	E	EWYT560B-XS(L)(R)A2	D
EWYT590B-SS(L)(R)A2	F	EWYT600B-XS(L)(R)A2	E
EWYT630B-SS(L)(R)A2	F	EWYT630B-XS(L)(R)A2	E
		EWYT650B-XS(L)(R)A2	E

Pumps Kits Data

Model	Single LL	Single HL	Double LL	Double HL	Single LL	Single HL	Double LL	Double HL	TANK [L]
	MAX POWER [kW]	MAX POWER [kW]	MAX POWER [kW]	MAX POWER [kW]	MAX CURRENT [A]	MAX CURRENT [A]	MAX CURRENT [A]	MAX CURRENT [A]	
EWYT085B-SS(L)(R)A1	1.5	3	1.5	3	2.7	5.3	2.7	5.3	70
EWYT105B-SS(L)(R)A1	1.5	3	1.5	3	2.7	5.3	2.7	5.3	145
EWYT135B-SS(L)(R)A1	1.85	4	3	5.5	3.3	6.8	5.3	9.3	145
EWYT175B-SS(L)(R)A1	3	5.5	4	5.5	5.3	9.3	6.8	9.3	190
EWYT215B-SS(L)(R)A1	4	5.5	4	5.5	6.8	9.3	6.8	9.3	250
EWYT205B-SS(L)(R)A2	3	9.2	3	7.5	5.5	15.6	5.5	12.7	250
EWYT235B-SS(L)(R)A2	4	9.2	5.5	9.2	6.8	15.6	9.3	15.6	280
EWYT255B-SS(L)(R)A2	4	9.2	5.5	9.2	6.8	15.6	9.3	15.6	280
EWYT300B-SS(L)(R)A2	5.5	11	5.5	11	9.3	18.5	9.3	18.5	390
EWYT340B-SS(L)(R)A2	5.5	9.2	5.5	9.2	9.3	15.6	9.3	15.6	390
EWYT390B-SS(L)(R)A2	7.5	11	7.5	11	12.7	18.5	12.7	18.5	390
EWYT430B-SS(L)(R)A2	7.5	15	7.5	11	12.7	24.6	12.7	18.5	550
EWYT490B-SS(L)(R)A2	7.5	15	7.5	11	12.7	24.6	12.7	18.5	550
EWYT540B-SS(L)(R)A2	9.2	15	9.2	15	15.6	24.6	15.6	24.6	550
EWYT590B-SS(L)(R)A2	9.2	15	9.2	15	15.6	24.6	15.6	24.6	750
EWYT630B-SS(L)(R)A2	11	15	11	15	18.5	24.6	18.5	24.6	750
EWYT085B-XS(L)(R)A1	1.5	3	1.5	3	2.7	5.3	2.7	5.3	145
EWYT115B-XS(L)(R)A1	1.5	3	1.5	3	2.7	5.3	2.7	5.3	190
EWYT135B-XS(L)(R)A1	1.85	4	1.85	5.5	3.3	6.8	3.3	9.3	190
EWYT175B-XS(L)(R)A1	3	4	3	5.5	5.3	6.8	5.3	9.3	250
EWYT215B-XS(L)(R)A1	4	5.5	4	5.5	6.8	9.3	6.8	9.3	280
EWYT215B-XS(L)(R)A2	3	7.5	3	5.5	5.5	12.7	5.5	9.3	280
EWYT235B-XS(L)(R)A2	3	7.5	4	5.5	5.5	12.7	6.8	9.3	390
EWYT265B-XS(L)(R)A2	4	7.5	4	7.5	6.8	12.7	6.8	12.7	390
EWYT310B-XS(L)(R)A2	4	7.5	4	7.5	6.8	12.7	6.8	12.7	390
EWYT350B-XS(L)(R)A2	5.5	9.2	5.5	9.2	9.3	15.6	9.3	15.6	550
EWYT400B-XS(L)(R)A2	7.5	9.2	5.5	9.2	12.7	15.6	9.3	15.6	550
EWYT440B-XS(L)(R)A2	7.5	9.2	7.5	9.2	12.7	15.6	12.7	15.6	550
EWYT500B-XS(L)(R)A2	7.5	11	7.5	11	12.7	18.5	12.7	18.5	750
EWYT560B-XS(L)(R)A2	7.5	11	7.5	11	12.7	18.5	12.7	18.5	750
EWYT600B-XS(L)(R)A2	7.5	15	9.2	15	12.7	24.6	15.6	24.6	750
EWYT630B-XS(L)(R)A2	9.2	15	9.2	15	15.6	24.6	15.6	24.6	750
EWYT650B-XS(L)(R)A2	9.2	15	9.2	15	15.6	24.6	15.6	24.6	750

Maximum cable dimension

Maximum cable dimension that can be physically connected to main switch of the unit. The table below can change in case of High Ambient Kit is selected.

PARALLEL Coil Layout			DOUBLE V Coil layout		
Model	Main Switch Size [A]	Max Cable Size [mm ²]	Model	Main Switch Size [A]	Max Cable Size [mm ²]
EWYT085B-SS(L)(R)A1	160	3x70 mm ² PE 1x35mm ²	EWYT300B-SS(L)(R)A2	400	3x240 mm ² PE 1x120mm ²
EWYT105B-SS(L)(R)A1	160	3x70 mm ² PE 1x35mm ²	EWYT340B-SS(L)(R)A2	400	3x240 mm ² PE 1x120mm ²
EWYT135B-SS(L)(R)A1	160	3x70 mm ² PE 1x35mm ²	EWYT390B-SS(L)A2	630	3x2x185 mm ² PE 1x185mm ²
EWYT175B-SS(L)(R)A1	200	3x95 mm ² PE 1x50mm ²	EWYT430B-SS(L)(R)A2	630	3x2x185 mm ² PE 1x185mm ²
EWYT215B-SS(L)(R)A1	250	3x120 mm ² PE 1x70mm ²	EWYT490B-SS(L)(R)A2	630	3x2x185 mm ² PE 1x185mm ²
EWYT205B-SS(L)(R)A2	250	3x120 mm ² PE 1x70mm ²	EWYT540B-SS(L)(R)A2	630	3x2x185 mm ² PE 1x185mm ²
EWYT235B-SS(L)(R)A2	250	3x120 mm ² PE 1x70mm ²	EWYT590B-SS(L)A2	800	3x2x240 mm ² PE 1x240mm ²
EWYT255B-SS(L)(R)A2	400	3x240 mm ² PE 1x120mm ²	EWYT630B-SS(L)(R)A2	800	3x2x240 mm ² PE 1x240mm ²
EWYT085B-XS(L)(R)A1	160	3x70 mm ² PE 1x35mm ²	EWYT310B-XS(L)(R)A2	400	3x240 mm ² PE 1x120mm ²
EWYT115B-XS(L)(R)A1	160	3x70 mm ² PE 1x35mm ²	EWYT350B-XS(L)(R)A2	400	3x240 mm ² PE 1x120mm ²
EWYT135B-XS(L)(R)A1	160	3x70 mm ² PE 1x35mm ²	EWYT400B-XS(L)(R)A2	630	3x2x185 mm ² PE 1x185mm ²
EWYT175B-XS(L)(R)A1	200	3x95 mm ² PE 1x50mm ²	EWYT440B-XS(L)(R)A2	630	3x2x185 mm ² PE 1x185mm ²
EWYT215B-XS(L)(R)A1	250	3x120 mm ² PE 1x70mm ²	EWYT500B-XS(L)(R)A2	630	3x2x185 mm ² PE 1x185mm ²
EWYT215B-XS(L)(R)A2	250	3x120 mm ² PE 1x70mm ²	EWYT560B-XS(L)(R)A2	630	3x2x185 mm ² PE 1x185mm ²
EWYT235B-XS(L)(R)A2	250	3x120 mm ² PE 1x70mm ²	EWYT600B-XS(L)A2	800	3x2x240 mm ² PE 1x240mm ²
EWYT265B-XS(L)(R)A2	400	3x240 mm ² PE 1x120mm ²	EWYT630B-XS(L)(R)A2	800	3x2x240 mm ² PE 1x240mm ²
			EWYT650B-XS(L)(R)A2	800	3x2x240 mm ² PE 1x240mm ²
			EWYT390B-SRA2	400	3x240 mm ² PE 1x120mm ²
			EWYT590B-SRA2	630	3x2x185 mm ² PE 1x185mm ²
			EWYT600B-XRA2	630	3x2x185 mm ² PE 1x185mm ²

Water filter pressure drops

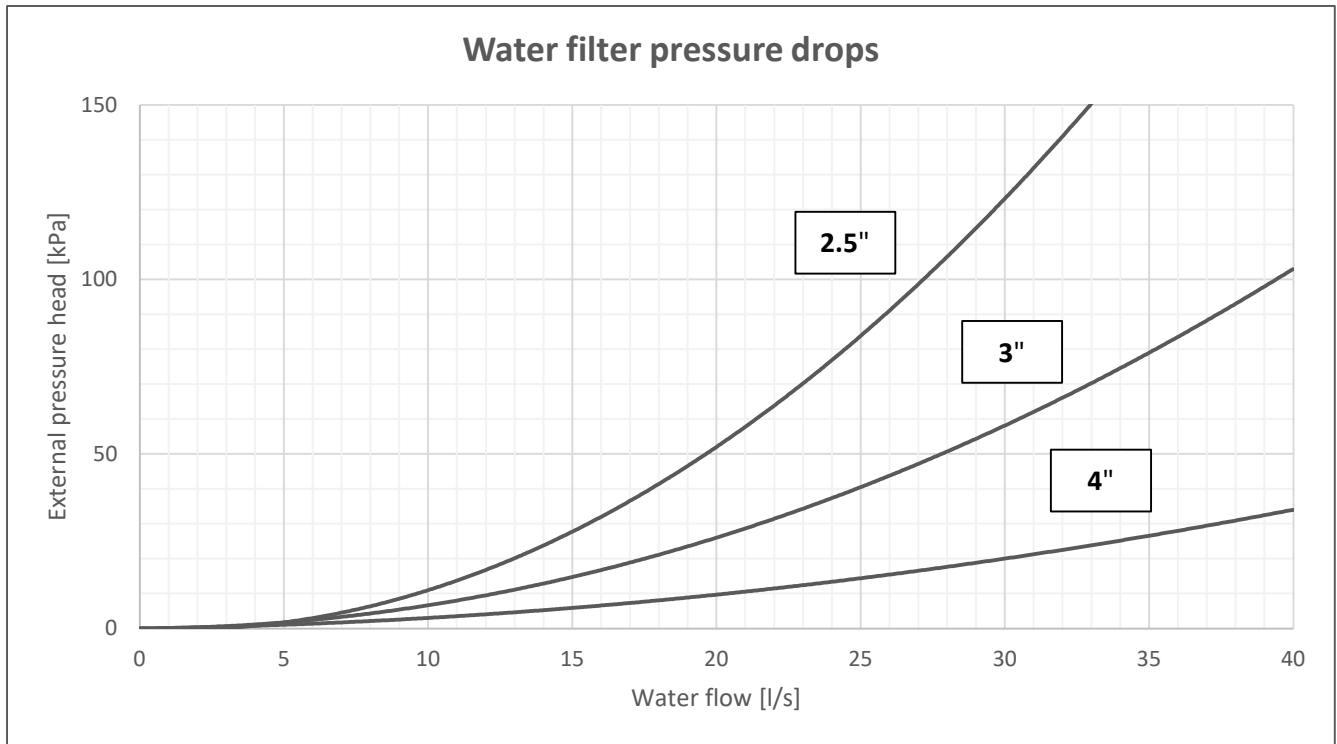

Soft Starter Values of the Inrush Current, in case of soft starter selected, are showed here below in the table. The vaues are calculated in case of the biggest compressor switching on with all the other compressors and fans on.

Model	Inrush Current with Soft Starter [A]	Model	Inrush Current with Soft Starter [A]	Model	Inrush Current with Soft Starter [A]
EWYT085B-SS(L)(R)A1	143	EWYT300B-SS(L)(R)A2	420	EWYT310B-XRA2	428
EWYT105B-SS(L)(R)A1	196	EWYT340B-SS(L)(R)A2	454	EWYT350B-XRA2	462
EWYT135B-SS(L)(R)A1	212	EWYT390B-SS(L)(R)A2	492	EWYT400B-XRA2	496
EWYT175B-SS(L)(R)A1	317	EWYT430B-SS(L)(R)A2	522	EWYT440B-XRA2	530
EWYT215B-SS(L)(R)A1	349	EWYT490B-SS(L)(R)A2	568	EWYT500B-XRA2	580
EWYT205B-SS(L)(R)A2	276	EWYT540B-SS(L)(R)A2	613	EWYT560B-XRA2	629
EWYT235B-SS(L)(R)A2	293	EWYT590B-SS(L)(R)A2	651	EWYT600B-XRA2	663
EWYT255B-SS(L)(R)A2	307	EWYT630B-SS(L)(R)A2	681	EWYT630B-XRA2	697
				EWYT650B-XRA2	697
EWYT085B-XS(L)(R)A1	145	EWYT310B-XS(L)A2	418		
EWYT115B-XS(L)(R)A1	198	EWYT350B-XS(L)A2	450		
EWYT135B-XS(L)(R)A1	212	EWYT400B-XS(L)A2	483		
EWYT175B-XS(L)(R)A1	319	EWYT440B-XS(L)A2	515		
EWYT215B-XS(L)(R)A1	351	EWYT500B-XS(L)A2	563		
EWYT215B-XS(L)(R)A2	280	EWYT560B-XS(L)A2	611		
EWYT235B-XS(L)(R)A2	296	EWYT600B-XS(L)A2	644		
EWYT265B-XS(L)(R)A2	311	EWYT630B-XS(L)A2	676		
		EWYT650B-XS(L)A2	697		

Water filter The installation of the filter is mandatory. Recommended maximum mesh size is equal to 1,0 mm. Water filter has to be installed as close as possible to the unit. If the unit is installed in a different part of the hydraulic system, the installer must ensure the cleaning of the water pipes between water filter and Water Side Heat Exchanger. The pressure drop value showed in CSS (Unit Selection Software) are referred to unit's Water Side Heat Exchanger only. For EWYT~B the water filter is available as option on request (shipped loose).

Warning Installation and maintenance of the unit must be performed only by qualified personnel who have knowledge with local codes and regulations and experience with this type of equipment, unit installation in places that could be considered dangerous for maintenance operations must be avoided.

Location The units are produced for outdoor installation on roofs, floors or below ground level on condition that the area is free from obstacles for the passage of the Air Side Heat Exchanger air. The unit should be positioned on solid foundations and perfectly leveled; in the case of installation on roofs or floors, it may be advisable to arrange the use of suitable weight distribution beams. When the units are installed on the ground, a concrete base at least 250 mm wider and longer than the unit's footprint should be laid. Furthermore, this base should withstand the unit weight mentioned in the technical data table.

Space requirements The units are air-cooled, then it is important to respect the minimum distances which guarantee the best ventilation of the Air Side Heat Exchanger coils. Limitations of space reducing the air flow could cause significant reductions in cooling capacity and an increase in electricity consumption. To determinate unit placement, careful consideration must be given to assure a sufficient air flow across the Air Side Heat Exchanger heat transfer surface. Two conditions must be avoided to achieve the best performance: warm air recirculation and coil starvation. Both these conditions cause an increase of condensing pressures that results in reductions in unit efficiency and capacity. Moreover, the unique microprocessor can evaluate the operating environment of the air-cooled unit and is capable to optimize performances staying on-line during abnormal conditions.

Each side of the unit must be accessible after installation for periodic service. The following pictures shows you minimum recommended clearance requirements.

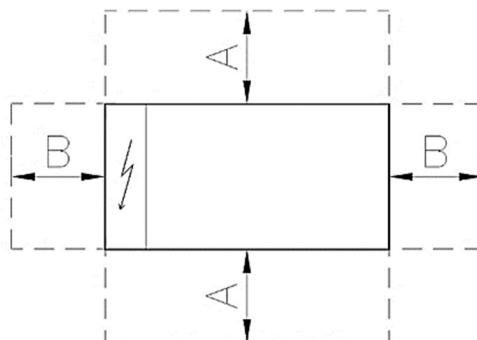

	Parallel Coil	Double V Coil
A	1100 mm	2200 mm
B	1100 mm	1500 mm

For single unit installation in proximity of a wall the following indications are recommended:

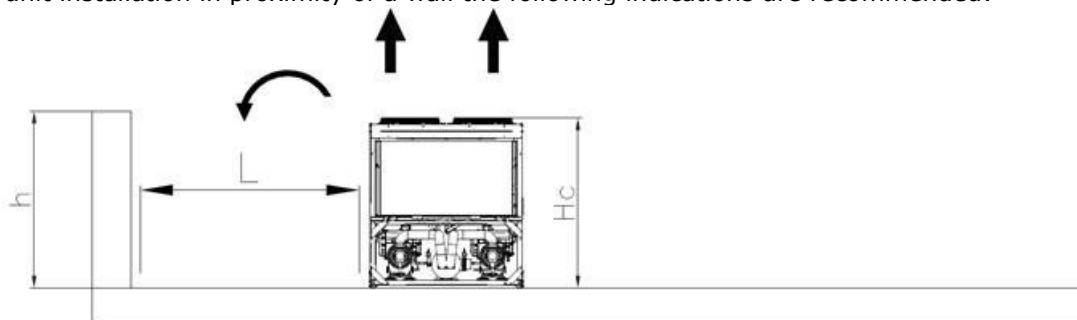

- if $h < H_c \rightarrow L$ must at least 3 m for Double V Coil layout units or 1,8m for Parallel Coil layout units
- if $h \geq H_c$ or L lower than recommended contact Daikin representative to evaluate possible arrangements

In case two units installed side by side in free filed, the minimum distance recommended between the units is indicated in the below picture

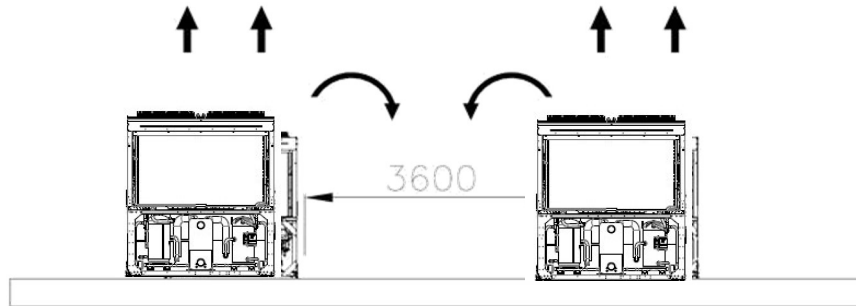

For mutiple unit installation it is recommended to install the units is a single row as hown in the picture below

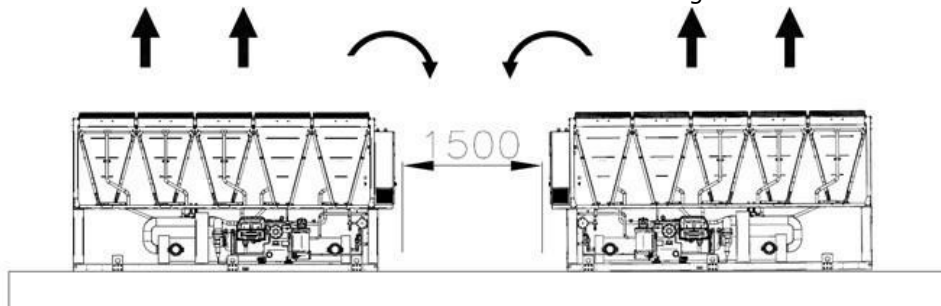

For additional information refer to the Installation Manual. If the site does not allow this kind of installation contact Daikin representative to evaluate possible arrangements.

Multiple units installation – free field with wind prevalent direction

Considering an installation in areas with prevailing wind direction (as represented in the first image below):

- Unit n,1: operates with no air overtemperature
- Unit n,2: operates in heated environment caused by Unit n,1 and by itself
- Unit n,3: operates in partially heated environment caused by Unit n,2

To reduce the effect of prevailing wind, it is oportune to set the units main dimension parallel to the wind prevailing wind (as represented in the second image below).

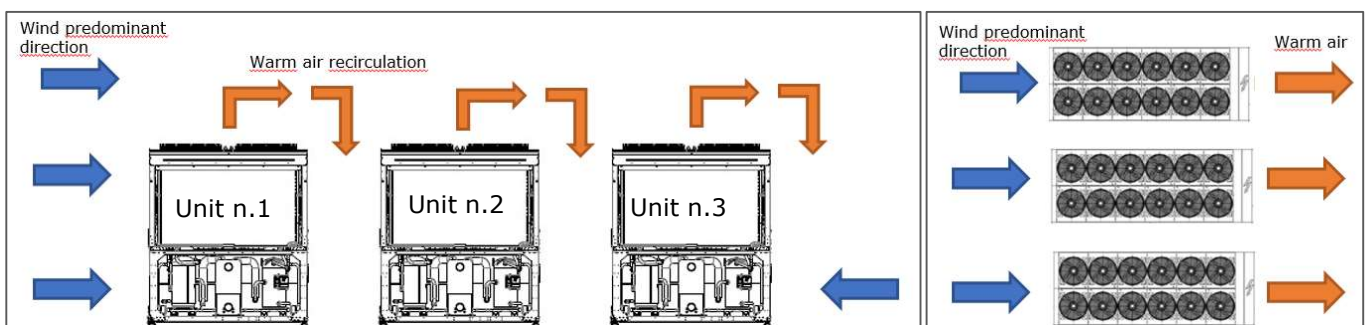

Multiple units installation – closed area with wind prevalent direction

In case of closed area with height equal or higher than the units, installation is not recommended. Units 2 and 3 operate at significantly higher temperatures due to the higher recirculation. In this case it is necessary to adopt special precautions based on the specific installation (for example: walls with grids, installation of the unit on base to increase its height, duct on fans, high head fans, etc.)

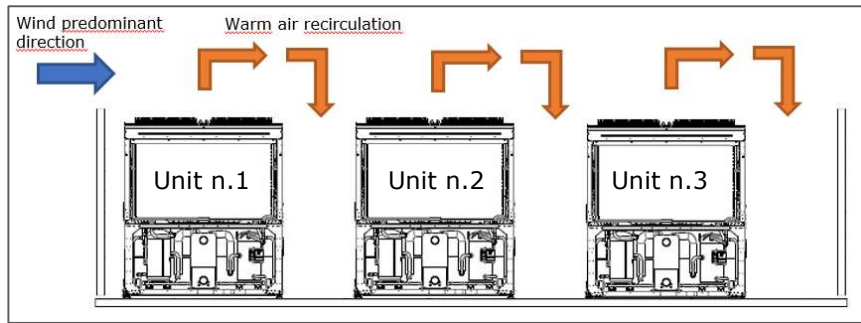

Hydraulic schemes

- **Hydraulic scheme without pump(s) on board (max. operating pressure 20 bar)**

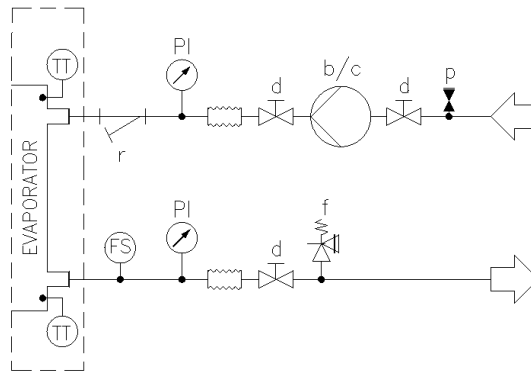

- **Hydraulic scheme of the Parallel Coil unit with Single Pump OP.78-79 (max operating pressure 6 bar)**

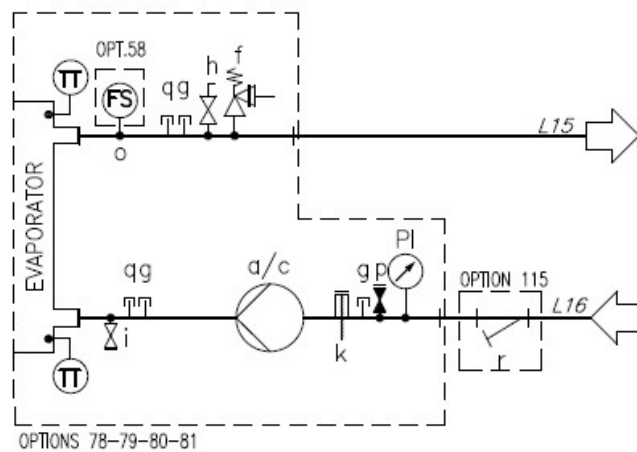

- **Hydraulic scheme of the Parallel Coil unit with Single Pump and Tank OP.134-135**
(max operating pressure 6 bar)

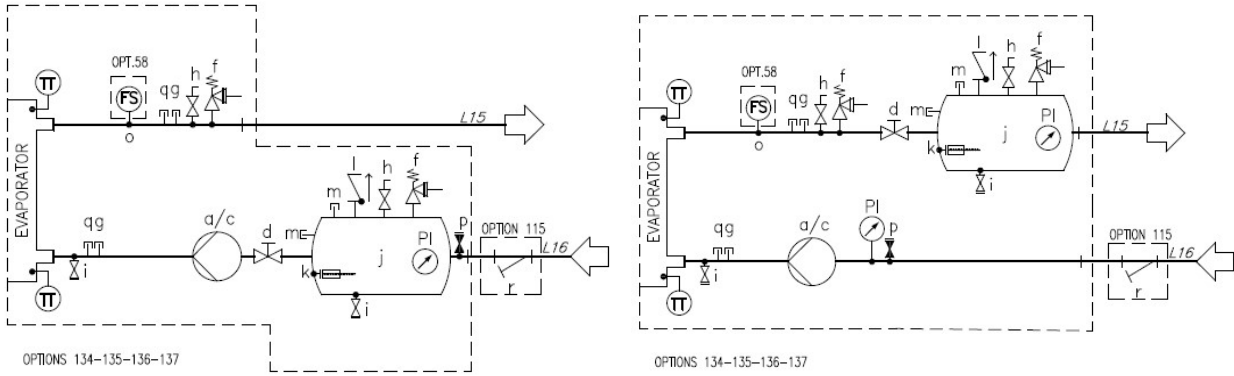

- **Hydraulic scheme of the Parallel Coil unit with Double Pump with and without Tank OP. 80-81/136-137**
(max operating pressure 6 bar)

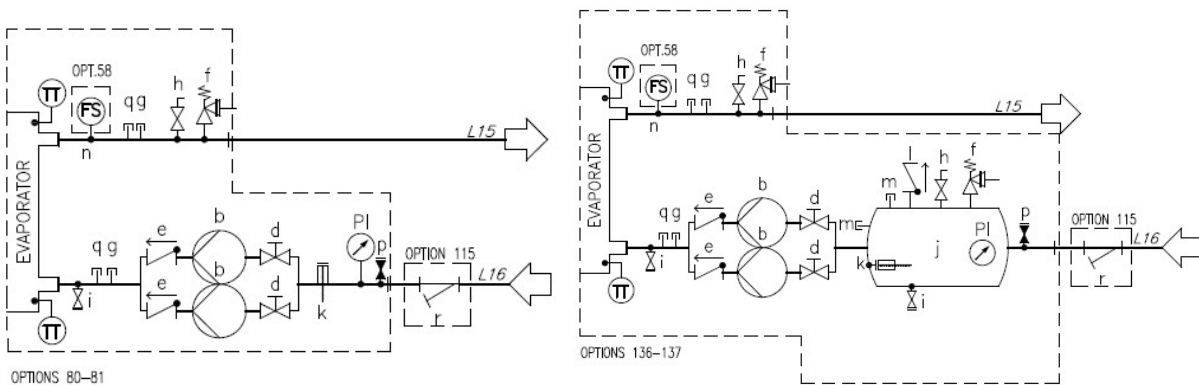

- **Hydraulic scheme of the Double V unit with Pump(s) and tank OP. 78-79-80-81/134-135-136-137**
(max operating pressure 6 bar)

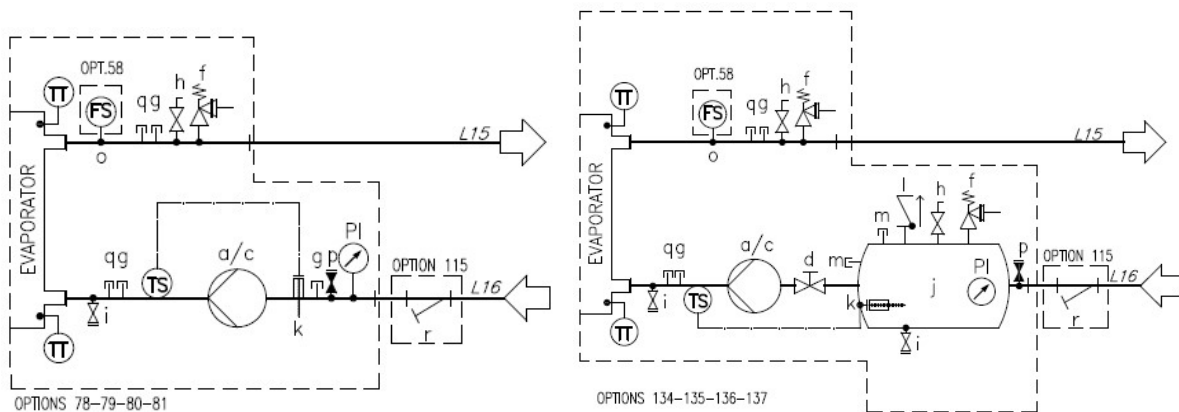

Legend;

a	Single Pump	l	Check valve
b	Two pumps- parallel configuration	m	Plugged fitting
c	Twin pump	n	Flow switch fitting 1"
d	Valve	o	Flow switch fitting ½ "
e	Check Valve	p	Automatic filling valve fitting
f	Safety Valve	q	Plugged fitting
g	Plugged fitting	r	Water filter
h	Air vent	TT	Temperature sensor
i	drain	TS	Temperature switch
j	Tank	PI	Pressure gauge
k	Electrical heater	FS	Flow switch

General The unit will be designed and manufactured in accordance with the following European directives:

- Construction of pressure vessel 2014/68/EU
- Machinery Directive 2006/42/EC
- Low Voltage 2014/35/EU
- Electromagnetic Compatibility 2014/30/EU
- Harmonized standard EN 60204-1 Safety of Machinery
- Manufacturing Quality Standards UNI – UNI EN 14000

The unit will be tested at full load in the factory (at the nominal working conditions and water temperatures).

The unit will be delivered to the job site completely assembled and charged with refrigerant and oil.

The installation of the unit must comply with the manufacturer’s instructions for rigging and handling equipment.

The unit will be able to start up and operate (as standard) at full load with:

- Outside air temperature from..... °C to..... °C
- Water Side Heat Exchanger leaving fluid temperature between..... °C and..... °C

Refrigerant HFC R-32

Performance Unit shall supply the following performances:

- Number of unit(s):..... unit(s)
- Cooling capacity for single unit:..... kW
- Power input for single unit in cooling mode:..... kW
- Heat exchanger entering water temperature in cooling mode:..... °C
- Heat exchanger leaving water temperature in cooling mode:..... °C
- Heat exchanger water flow in cooling:..... l/s
- Nominal outside working ambient temperature in cooling mode:..... °C
- Minimum full load efficiency (EER): (kW/kW)
- Minimum part load efficiency (SEER): (kW/kW)
- Heating capacity for single unit:..... kW
- Power input for single unit in heating mode:..... kW
- Heat exchanger entering water temperature in heating mode:..... °C
- Heat exchanger leaving water temperature in heating mode:..... °C
- Heat exchanger water flow in heating:..... l/s
- Nominal outside working ambient temperature in heating mode:..... °C
- Minimum full load efficiency (COP): (kW/kW)
- Minimum part load efficiency (SCOP): (kW/kW)

Operating voltage range should be 400V ±10%, 3ph, 50Hz (or 380V ±10%, 3ph, 60Hz), voltage unbalance maximum 3%, without neutral conductor and shall only have one power connection point.

Unit description Unit shall include one or two independent refrigerant circuits, hermetic orbiting scroll type optimized for R-32 operation, electronic expansion device (EEXV), direct expansion, PHE Water Side Heat Exchanger, air-cooled Air Side Heat Exchanger section made with aluminum Microchannel technology, R-32 refrigerant, lubrication system, motor starting components, control system and all components necessary for a safe and stable unit operation.
The unit will be factory assembled on a robust base frame made of galvanized steel, protected by an epoxy paint.

Sound level and vibrations Sound power level shall not exceeddB(A). The sound power levels must be rated in accordance to ISO 9614 (other types of rating cannot be used). Vibration on the base frame should not exceed 2 mm/s.

Dimensions Unit dimensions shall not exceed following indications:

- Unit length..... mm
- Unit width..... mm
- Unit height..... mm

Compressors

Hermetic orbiting scroll type optimized for R-32 operation and complete with motor over-temperature and over-current protection devices. Each compressor equipped with oil heater that keeps the oil from being diluted by the refrigerant when the unit is not running. Each compressor is mounted on rubber antivibration mounts for a quiet operation. Unit is delivered with complete oil charge.

Water Side Heat Exchanger

The units shall be equipped with a direct expansion plate to plate type Water Side Heat Exchanger

- The Water Side Heat Exchanger will be made of stainless steel brazed plates and shall be linked with an electrical heater controlled by a thermostat and shall be insulated with flexible, closed cell polyurethane insulation material
- The water connections shall be VICTAULIC type connections as standard to ensure quick mechanical disconnection between the unit and the hydronic network
- The Water Side Heat Exchanger will be manufactured in accordance to PED approval
- Flow switch on Water Side Heat Exchanger available as option (shipped loose)
- Water filter on Water Side Heat Exchanger available as option (shipped loose)

Air Side Heat Exchanger coil The Air Side Heat Exchanger is made entirely of aluminum with flat tubes containing small channels.

Full - depth louvered aluminum fins are inserted between the tubes maximizing the heat exchange.

The Microchannel technology ensures the highest performance with the minimum surface for the exchanger. The quantity of refrigerant is also reduced compared to Cu/Al Air Side Heat Exchanger, Special treatments ensure resistance to the corrosion by atmospheric agents extending the life time (available on request).

Air Side Heat Exchanger fans The Air Side Heat Exchanger fans used in conjunction with the Air Side Heat Exchanger coils, shall be propeller with glass reinforced resin blades for higher efficiencies and lower sound. Each fan shall be protected by a fan guard.

- The air discharge shall be vertical and each fan must be coupled to the electrical motor, supplied as standard to IP54 and capable to work to ambient temperatures of - 20°C to + 65°C.
- The Air Side Heat Exchanger fans shall have as a standard a thermal protection by internal thermal motor.

Refrigerant circuit The unit shall have one or two independent refrigerant.

• The circuit shall include as standard: electronic expansion device dived by unit’s microprocessor control, liquid line shut-off valve, sight glass with moisture indicator, filter drier, charging valves, high pressure switch, high and low pressure transducers, oil pressure transducer and insulated suction line, Condensation control. The units will be provided with an automatic control for condensing pressure which ensures the working at low external temperatures down to - °C, to maintain condensing pressure.

• The unit automatically unloads when abnormal high condensing pressure is detected. This to prevent the shutdown of the refrigerant circuit (shutdown of the unit) due to a high-pressure fault.
The compressor shall be connected to unit’s metal base frame by rubber anti vibration supports to prevent the transmission of vibrations to all metal unit structure, in order to limit the unit noise emissions. The unit shall be provided with an acoustical compressor enclosure (according to the version). This enclosure shall be realized with a light, corrosion resisting aluminum structure and metal panels. The compressor sound-proof enclosure (available as option) shall be internally fitted with flexible, multi-layer, high density materials.

Hydronic kit (on request) The hydronic module shall be integrated in the unit chassis without increasing its dimensions and includes the following elements: centrifugal pump with motor protected by a circuit breaker installed in control panel, water filling system with pressure gauge, safety valve, drain valve,

- The hydronic module shall be assembled and wired to the control panel
- The water piping shall be protected against corrosion and freezing and insulated to prevent condensation
- A choice of two pump types shall be available:
 - in-line single pump
 - in-line twin pumps

The unit should be able to operate in Primary only system with two-ways valve on terminals with Variable Primary Flow control strategy (available as option on request).

Master/Slave

The unit shall be able to operate in Master / Slave mode in order to be connected with another similar unit (up to 4), The master unit shall manage the slave units connected in series on the hydraulic plant with the aim of optimize the running hours of each compressor and to balance running hours and the load between the units.

Electrical control panel

Power and control shall be located in the main panel that will be manufactured to ensure protection against all weather conditions.

- The electrical panel shall be IP54 and (when opening the doors) internally protected against possible accidental contact with live parts
- The main panel shall be fitted with a main switch interlocked door that shuts off power supply when opening
- The power section will include compressors and fans starter devices

Controller

The controller will be installed as standard and it will be used to modify unit set-points and check control parameters.

- A built-in display will shows unit operating status plus temperatures and pressures of water, refrigerant and air, programmable values, set-points
- A sophisticated software with predictive logic, will select the most energy efficient combination of compressors, EEXV and Air Side Heat Exchanger fans to keep stable operating conditions to maximize unit energy efficiency and reliability
- The controller will be able to protect critical components based on external signals received from the unit itself (such as motor temperatures, refrigerant gas and oil pressures, correct phase sequence, pressure switches and Water Side Heat Exchanger flow switch). The input coming from the high pressure switch cuts all digital output from the controller in less than 50ms, this will be an additional safety for the equipment.
- Fast program cycle (200ms) for a precise monitoring of the system
- Floating point calculations supported for increased accuracy in P/T conversions

Controller features

Controller shall be guarantee following minimum functions:

- Management of the compressors,
- Unit enabled to work in partial failure condition
- Full routine operation at condition of:
 - high ambient temperature value
 - high thermal load
 - high Water Side Heat Exchanger entering water temperature (start-up)
- Display of Water Side Heat Exchanger entering/leaving water temperature
- Display of Outdoor Ambient Temperature
- Display of condensing-evaporating temperature and pressure, suction and discharge superheat for each circuit
- Leaving water Water Side Heat Exchanger temperature regulation
- Compressor and Water Side Heat Exchanger pumps hours counter
- Display of Status Safety Devices
- Number of starts and compressor working hours

- Optimized management of unit load
- Fan management according to condensing pressure
- Re-start in case of power failure (automatic / manual)
- Soft Load (optimized management of the unit load during the start-up)
- Start at high Water Side Heat Exchanger water temperature
- Return Reset (Set Point Reset based on return water temperature)
- OAT (Outside Ambient temperature) set-point reset
- Set point Reset from external signal (optional)
- Application and system upgrade with commercial SD cards
- Ethernet port for remote or local servicing using standard web browsers
- Master / Slave (provided as standard)
- Variable primary Flow (available as option)
- Two different sets of default parameters could be stored for easy restore

High Level Communications Interface (on request)

The unit shall be able to communicate to BMS (Building Management System) based on the most common protocols as:

- ModbusRTU
- LonWorks, now also based on the international 8040 Standard Unit Profile and LonMark Technology
- BacNet BTP certified over IP



In all of us,
a green heart



Daikin's unique position as a manufacturer of air conditioning equipment, compressors and refrigerants has led to its close involvement in environmental issues. For several years Daikin has had the intention to become a leader in the provision of products that have limited impact on the environment. This challenge demands the eco design and development of a wide range of products and an energy management system, resulting in energy conservation and a reduction of waste.



The present leaflet is drawn up by way of information only and does not constitute an offer binding upon Daikin Europe N.V. Daikin Europe N.V. has compiled the content of this leaflet to the best of its knowledge. No express or implied warranty is given for the completeness, accuracy, reliability or fitness for particular purpose of its content and the products and services presented therein. Specifications are subject to change without prior notice. Daikin Europe N.V. explicitly rejects any liability for any direct or indirect damage, in the broadest sense, arising from or related to the use and/or interpretation of this leaflet. All content is copyrighted by Daikin Europe N.V.



www.eurovent-certification.com
www.certiflash.com

Daikin products are distributed by: