



Installation, operation and  
maintenance manual

Professional

D-EIMAH00105-15\_02EN



To download this manual in other  
languages, scan the QR code or visit  
the web site

[https://www.daikin.eu/en\\_us/products/d-ahu-professional.html](https://www.daikin.eu/en_us/products/d-ahu-professional.html)

Translation of the original instructions

REV	02
DATE	December 2021
REPLACES	D-EIMAH00105-15_01EN

## **Daikin Applied Europe S.p.A. – All rights reserved**

This Installation, Use and Maintenance Manual is entrusted to users of the Professional Units, for the training of the technicians in charge of installation and maintenance. The instructions contained in this manual are of a confidential technical nature and cannot be reproduced and/or disclosed, either completely or partially, without a specific written authorization from the company.

It is explicitly forbidden for technicians and operators to divulge the information contained and to use this manual for purposes other than those strictly related to the correct installation and maintenance of the product.

Daikin Applied Europe cannot be held responsible or liable for damage caused by the incorrect use of the documentation.

# Summary

## Important warnings 4

Warnings for the operator	5
Service	5
Purpose of the manual	5
Intended use of the machine	5
Safety regulations	6
What to do in case of accident?	8
Information ownership	8
Residual risks	9
Safety devices	10
General information on safety	11
Passive safety measures	12
Safety signs	13
Active safety measures	14
Components present in the air handling unit	14
Training	14
Optional	14

## Machine characteristics 15

Fan section	15
Filtering section	18
Recuperators	22
Coils	23
Humidification section	23
Dampers	24
Silencers	25
UVC lamps	25

## Receiving of the packages 28

Read the packaging symbols	28
----------------------------	----

## Transport 29

Lifting	29
Lifting using hooks	30
Lifting using a pallet truck	32
Lifting non-palletised equipment	32

## Unpacking and verification of integrity 33

After unpacking	33
Reading the serial number plate	34
Storage waiting for installation	35

## Installation 36

Step 1: Position the unit	38
Step 2: Section coupling procedure	39
Step 3: Fasten the units to the ground (optional)	43
Step 4: roof assembly procedure	45
Step 5: Make the connections	48
Step 6: Perform a trial run	74

## Control instructions and preparation for the start-up of the unit and its maintenance 75

Generalities	75
Water coil	76
Electric heaters	77
Indirect drive fans (belts and pulleys)	78
Humidifiers	82
Cross-flow and counter-flow heat exchangers	83
Rotary heat exchangers	83
Rotary heat exchanger alignment/adjustment	90
Checking the unit safety devices	93
Use of the unit	94
Electrical connection for Digital Plug & Play units	94
Digital board LED indicators	95
Pressure tap configuration (as from factory)	96

## Maintenance 102

Safety precautions for maintenance	102
Ordinary maintenance	103
Extraordinary maintenance	106
Diagnostics	108
Service	108
Troubleshooting table	109
Repair log	113

# 1 Important warnings



The pictogram shows a situation of immediate danger or a dangerous situation that might cause injuries or death.



The pictogram shows that it is necessary to adopt suitable behaviour in order to avoid jeopardising staff safety and cause damages to the equipment.



The pictogram shows particularly important technical information that should be taken into consideration by the people installing or using the equipment.



## IMPORTANT

**The machines covered by this manual represent an excellent investment and deserve attention and care both for a correct installation and for keeping them in good working condition.**

**Proper maintenance of the machinery is essential for its safety and reliability. All installation, assembly, connections to the electrical network and ordinary/extraordinary maintenance must be carried out only by technicians who comply with the legal requirements.**



## WARNING

**Before installing the unit, read this manual carefully. If you do not clearly understand the instructions in this manual, it is absolutely forbidden to operate the machine.**



## IMPORTANT

**This manual describes the features and procedures common to the entire series of units.**

**All units are shipped with a general drawing, with dimensions and weights characteristic of the specific machine.**

**THE SPECIFIC DRAWING MUST BE CONSIDERED AN INTEGRAL PART OF THIS MANUAL.**

**In case of discrepancy between this manual and the drawing, what is on the drawing will prevail.**

# Warnings for the operator

- **BEFORE USING THE UNIT READ THIS USER AND MAINTENANCE MANUAL**
- **THE OPERATOR MUST BE INSTRUCTED AND TRAINED TO USE THE UNIT**
- **THE OPERATOR MUST CAREFULLY FOLLOW ALL INSTRUCTIONS, SAFETY RULES AND LIMITS OF USE OF THE UNIT.**

## Service

Before carrying out any repairs, it is advisable to contact authorized personnel, especially if it is necessary to intervene for extraordinary maintenance.

## Purpose of the manual

This **manual** was drawn up in order to provide operators and technicians responsible for the installation and maintenance of the machine with the information and instructions that are vital and essential to operate correctly and in safe conditions.

The purpose of this **manual** is to guide the installer and qualified operator in the installation, maintenance and proper and safe use of the equipment. For this reason, **it is mandatory for all personnel involved in installation, maintenance and supervision of the machine to read this manual.**

Contact the manufacturer if any points are unclear or difficult to understand.

This manual contains information regarding:

- Technical specifications of the machine.
- Instructions for transport, handling, installation and assembly;
- Tuning after installation and use;
- Information for instructing personnel authorised for its use.
- Maintenance and demolition;

All the information refers to any Professional unit. All the units are shipped together with a **technical schematic** indicating the specific weight and size of the machine received. It must be considered an integral part of this manual and therefore it must be kept with the utmost care in all its parts.

If the manual or drawing is lost, it is important to request a copy from the manufacturer, specifying the unit's serial number and date of purchase that can be found on the invoice.

## Intended use of the machine

This appliance has the function of treating the air intended to condition civil and industrial environments. Any other use is not in accordance with the intended use and therefore dangerous.

This range is designed to be used in NON-explosive environments.

If the machine is used in critical situations, by type of system or environmental context, the customer must identify and adopt the technical and operational measures to avoid damage of any kind.

# Safety regulations

## Skills required for the installation of the machine



Installers must perform operations according to their professional qualifications: all activities not within one's expertise (i.e. electrical connections) must be carried out by specialised and qualified staff so as not to endanger one's safety and the safety of the other operators interacting with the machine.



**Transport and equipment handling operator:** authorised person with recognised expertise in using transport and lifting equipment.



**Technical installer:** expert technician, sent or authorized by the manufacturer or its representative, with adequate skills and training to install the machine.

**Assistant:** technician subject to care obligations while lifting and assembling the equipment. He must be suitably trained and informed about the operations to perform and the safety plans of the site/installation location.

In this manual, the technician competent to carry out each operation is specified.

## Skills required for the use and maintenance of the machine



**Generic operator:** AUTHORISED to run the machine using commands placed on the keypad of the electrical control panel. Performs only machine control operations, power on/off.

**Maintenance mechanic (qualified):** AUTHORISED to carry out maintenance, adjustments, replacement and repair of mechanical parts. It must be a person competent in mechanical systems, therefore able to perform mechanical maintenance in a satisfactory and safe manner, must possess theoretical preparation and manual experience. NOT AUTHORISED to work on electrical systems.

**Manufacturer's technician (qualified):** AUTHORISED to perform complicated operations in every situation. Operates in accordance with the user.



**Maintenance electrician (qualified):** AUTHORISED to perform service of an electric nature, adjustments, maintenance and electrical repairs. AUTHORISED to operate in the presence of an active electrical connection inside the control panels and junction boxes. It must be a person competent in electronics and electrical engineering, therefore able to work on electrical systems satisfactorily and safely, must possess theoretical knowledge and proven experience. NOT AUTHORISED to work on mechanical systems.



Installers, users and maintenance staff for the machine must also:

- Be responsible and experienced adults without physical impairments, in perfect psychological and physical condition.
- Master the machine's operating cycle, therefore participate in theoretical/practical training alongside an expert machine operator, or alongside a technician of the manufacturer.

In this manual, the technician competent to carry out each operation is specified.



Read this manual carefully before machine installation and maintenance and keep it for any further future consultation by the various operators. Do not remove, tear out or rewrite any part of this manual.



All installation, assembly, electrical connections to the mains and ordinary/extraordinary maintenance must be performed **only by qualified personnel authorised by the Retailer or Manufacturer** after turning off the unit electrically and using personal protective equipment (i.e., gloves, protective goggles, etc.), in compliance with the regulations in force in the country the equipment is to be used in and the laws regarding the systems and safety in the workplace.



Installation, use or maintenance other than those specified in the manual may cause damage, injury or death, invalidate the warranty and relieve the Manufacturer of any liability.



Use protective clothing and suitable equipment while handling or installing the equipment, in order to prevent accidents and safeguard your own and other people's safety. Individuals not assigned to installation or maintenance are NOT allowed to stand or pass through the work area while the machine is assembled.



**Disconnect the equipment from the mains before installing or maintaining it.**



Before installing the equipment, check that the systems comply with the legal provisions in force in the country of use and meet the specifications on the serial number plate.



It is the responsibility of the user/installer to check the static and dynamic stability relative to the installation and to arrange environments so that **people who are not competent or authorised DO NOT have access to the machine or to its commands.**



It is the responsibility of the user/installer to make sure that **weather conditions** do not affect the safety of persons and property during installation, use and maintenance.



Make sure the air intake is not located near any exhausts, flue-gases or other contaminating elements.



Do not install the equipment in places exposed to strong winds, salt air, open flames or temperatures exceeding 50°C (122°F) with indirect solar radiation.



After installation is complete, instruct the user on the correct use of the machine.

If the equipment does not work or functional or structural alterations are noted, disconnect it from the mains and contact a service centre authorised by the Manufacturer or Retailer, without attempting to repair it on your own. For any replacements request the use of original spare parts.

Unauthorised actions, tampering or modifications that do not follow the information provided in this manual can cause damage, injuries or fatal accidents and void the warranty.

The serial number plate on the unit provides important technical information, essential in case of machine maintenance or repairs. We recommend that you do not remove, damage or modify it.

In order to ensure correct and safe conditions of use, it is recommended to have the unit maintained and checked at least annually by a service centre authorised by the manufacturer or dealer.

**Failure to follow these instructions may cause damage and injuries, even fatal, voids the warranty and relieves the Manufacturer of any liability.**

# Information ownership

This Manual contains proprietary information. All rights reserved.

This manual may not be reproduced or photocopied, in whole or in part, without the Manufacturer's prior written consent.

The use of this documentary material is allowed only to the customer to whom the manual has been supplied as a kit for the machine and only for the purposes of installation, use and maintenance of the machine to which the manual refers.

The Manufacturer declares that the information contained in this manual is congruent with the technical and safety specifications of the machine to which the manual refers.

The drawings, diagrams and technical data shown are updated to the date of publication of this document and are valid exclusively for the machine they accompanied.

The Manufacturer reserves the right to make changes or improvements to this documentary material without notice.

The Manufacturer accepts no responsibility for direct or indirect damage to persons, things or pets resulting from the use of this documentary material or the machine in conditions other than those provided for.



# Residual risks

Despite having implemented and adopted all the safety measures indicated by applicable regulations, some residual risks remain. In particular, in some operations of replacement, adjustment and tooling maximum attention is always required in order to work in the best possible conditions.

## List of operations with residual risks

Risks for qualified personnel (electrician and mechanic)

- Handling - during unloading and handling it is necessary to pay attention to all the steps listed in this manual regarding the points of reference
- Installation - during installation it is necessary to pay attention to all the steps listed in this manual regarding the points of reference. The installer must ensure the static and dynamic stability of the machine's site of installation.
- Maintenance - during maintenance it is necessary to pay attention to all the steps listed in this manual, and in particular to high temperatures that may be present in the heat transfer fluid lines to/from the unit.
- Cleaning - the machine must be cleaned only when it is switched off, by turning off the switch installed by the electrician and the switch located on the unit itself. The key for interrupting the power supply must be kept by the operator until the end of the cleaning operations. Internal cleaning of the machine must be carried out using the protections required by current regulations. While the inside of the machine does not contain particular hazards, it is necessary to pay the utmost attention so that accidents do not occur during cleaning. The heat exchange coils that have a potentially sharp finned pack must be cleaned using protective glasses and gloves suitable for handling metals.

During adjustment, maintenance and cleaning there are residual risks of variable entity. Being operations that must be performed with guards disabled, it is necessary to pay particular attention in order to avoid damage to persons and things.



Always pay close attention when performing the operations specified above.

Remember that these operations must always be performed by authorised personnel. All work must be completed in accordance with the legal provisions relating to work safety. Remember that the unit in question is an integral part of a larger system that includes other components, depending on the final characteristics of realisation and the mode of use. Therefore in the end it is the responsibility of the user and assembler to assess the residual risks and their respective preventive measures.



For more information about the possible risks, please refer to the RAD (Risk Assessment Document) available from the manufacturer.

# Safety devices

For each of the operations described in this manual, the means of protection that the personnel in charge are required to use and the rules of conduct that allow to safeguard the safety of the operators themselves are indicated.



Always pay attention to the safety symbols on the machine. It should only operate with the safety devices engaged and with fixed or movable guards installed correctly and in the proper position.



If during installation, use or maintenance the safety devices have been temporarily removed or disabled, the machine can be operated **exclusively** by the qualified technician who made this change. It is **mandatory** to prevent other people's access to the machine. When finished, restore the devices to their proper status as soon as possible.



For installation, maintenance and demolition operations, the use of the following personal protective equipment is mandatory:



## Suitable protective clothing:



**Safety helmet**



**Safety footwear**

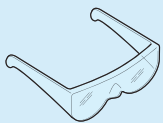

**Safety goggles**



**Cut-resistant gloves**



For each of the operations described in this manual, the means of protection that the personnel in charge are required to use are indicated (possibly in addition to those that the personnel is required to wear in the place of installation of the machine) together with the rules of conduct that allow safeguarding the safety of the operators themselves.

# General information on safety

## Design criteria

The principles and concepts contained in the harmonized standards indicated in **Table 2** were adopted for the design of the machine.

ACTIVITY	FREQUENCY
<b>EN ISO 12100: 2010</b>	Safety of machinery - General principles for design - Part 1: Basic terminology, methodology
<b>EN ISO 13857: 2019</b>	Safety of machinery - Safety distances to prevent hazard zones being reached by upper and lower limbs
<b>EN ISO 14120: 2015</b>	Safety of machinery - General requirements for the design and construction of fixed and movable guards
<b>IEC EN 60204-1: 2018</b>	Safety of machines - Electrical equipment of machines - Part 1: General requirements

*Table 2 - Main harmonized standards used in the design of air handling units*

Compliance with the relevant paragraphs of the aforementioned harmonized standards has made it possible to eliminate or reduce risks in the best possible way, during both normal operation and adjustment and maintenance operations, throughout the life cycle of the machine.

The components used have been carefully chosen from those available on the market, the materials making up the machine and the accessory tools do not constitute a risk to people's health and integrity. All parts supplied by third parties are CE marked (when required) and comply with the relevant reference directives. All the details have been strictly checked in compliance with the quality standards prescribed by the regulations in force.

Furthermore, the necessary warning and protection measures against residual risks (see, in this regard, the active passive safety measures described below) have been adopted for the machine.

# Passive safety measures



Metal structure that encloses the individual parts of the machine



Panic handles with opening also from inside the unit



Metal mesh or protective casing to protect the fan unit and the corresponding transmission components.



Safety signs on the external structure of the unit

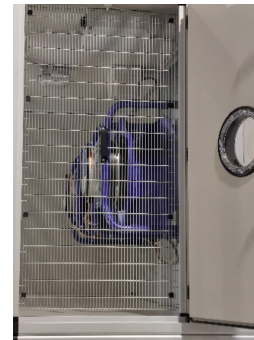

# Information signs



Fresh air right  
62x62 mm



Fresh air left  
62x62 mm



Damper  
62x62 mm



Cold water outlet  
62x62 mm



Condensate drain  
62x62 mm



Exhaust air right  
62x62 mm



Exhaust air left  
62x62 mm



Drop separator  
62x62 mm



Hot water outlet  
62x62 mm



Antifrost  
62x62 mm



Air supply right  
62x62 mm



Air supply left  
62x62 mm



Fans  
62x62 mm



Filter  
62x62 mm



Daikin  
310x70 mm



Return air right  
62x62 mm



Return air left  
62x62 mm



Electric coil  
62x62 mm



Heat exchange coil  
62x62 mm



Unit label  
102x102 mm



Cold water inlet  
62x62 mm



Heat recuperator  
62x62 mm



Liquid coolant inlet  
62x62 mm



Moving parts  
62x62 mm



Hot water inlet  
62x62 mm



Humidification  
62x62 mm



Vapour coolant outlet  
62x62 mm



Silencer  
62x62 mm



135x45 mm

# Safety signs



Lifting

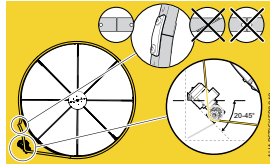

Belt tensioning

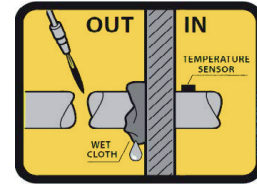

Risk of brazing the temperature sensor



Safety handle positive pressure



Roof film removal



Grounding



Fire hazard

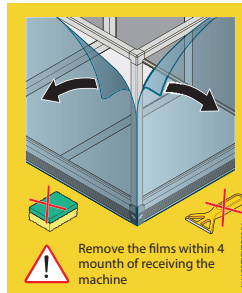

Remove the film from the panels



Electric shock hazard



Electrical hazard

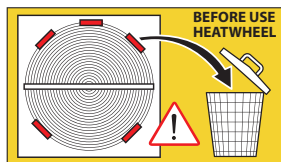

Removal of heat wheel blocks before the unit first start-up



Danger of running fans

## Safety warnings on the packaging

The following warning labels are present on the packaging of the machine

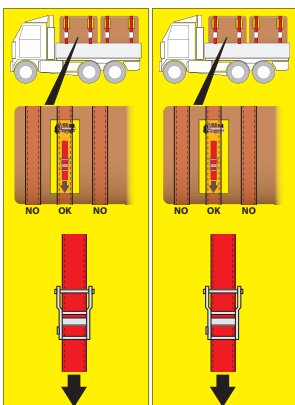

AHU load straps

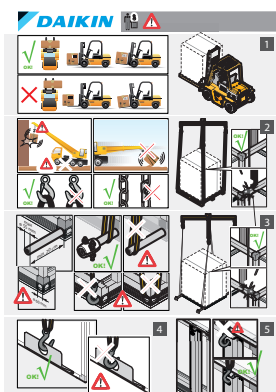

AHU safe handling

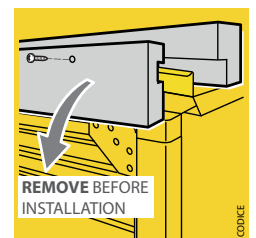
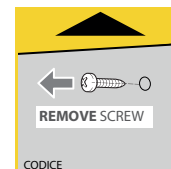

Removing wooden planks from the ceiling

# Active safety measures



Emergency button positioned on the control panel.



Magnetic microswitches installed in correspondence with the access doors of the fan sections on the machine (at the explicit request of the customer)



If the machine has an electric heat exchange battery, there is a thermostat capable of detecting the temperature of the battery itself and a manual reset safety thermostat.



Double click doors in correspondence of the positive pressure sections.

## Components present in the air handling unit

The machine is designed and built for air treatment. In general, no material present on the machine is dangerous for the operators responsible for managing the machine itself. However, it is necessary to pay attention to the handling operations of the filters, which could cause allergy or irritation to the operators.

The user of the machine must therefore provide adequate PPE (for example, goggles, masks, gloves or protective clothing), independent from the supply of the machine itself, to the operators who work in contact or within the range of action of the materials that generate hazards of the type indicated above. Waste products resulting from normal maintenance on the machine must be disposed of by the purchaser of the machine in compliance with the regulations in force in the country of installation of the machine. Disposal must be carried out in such a way as not to harm the environment, people and animals, in compliance with the relevant legislative provisions.

## Training

It is the responsibility of the machine buyer/user to provide adequate instruction and training to machine operators.

## Optional

In agreed cases, additional training may be provided through the one-on-one instruction of operators by the Manufacturer's technical staff.

## 2 Machine characteristics

The MACHINE is designed and built for air treatment and can have different configurations depending on the type of treatment requested by the customer. In this sense, the MACHINE consists of several sections, each of them with a specific function, which may or may not be present according to the type of treatment requested.

The supporting structure consists of profiles made by aluminium alloy extrusion. The stainless steel fixing screws are concealed in the profile itself so as to have smooth surfaces on the inside. The panels of the structure consist of two zinc-plated box press-folded sheets injected with polyurethane. Alternatively, as an insulator, mineral wool can be used. Where necessary, along the panels, doors with locked handles and/or portholes are installed to inspect the inside of the machine.

Find below the main sections of the machine.

### Fan section

The standard construction involves the use of single or twin double inlet centrifugal fans. The customer has the possibility to select the model, according to requirements. The available options are:

#### Double inlet centrifugal fans with backward curved or airfoil blades

The double inlet centrifugal fans belonging to this range have a steel impeller with backward curved blades of the flat or airfoil type, welded and painted, inlet cone with patented index, trapezoidal cut and low maintenance ball bearing. In particular, the augers are built with galvanized steel sheet and are stapled with the Pittsburgh method, which ensures high quality, perfect seal and sturdiness. The inlet nozzles are made of painted steel sheet and are fixed to the sides of the auger. A series of standard holes is arranged on the sides in order to allow the fixing of the frames. The impellers are keyed to the shaft with aluminium or steel hubs equipped with tab and tightening screw. All shafts are sized with a high safety factor and are made of carbon steel, turned and ground. The shafts have a keyway at the impeller hub and another at each end. All shafts are coated with protective paint. Finally, the fans must be fixed on a base frame in order to avoid deformations caused by the tension of the belt.



Fan with flat backward blades



Fan with backward airfoil blades

## Plug Fan

This range of fans consists of free centrifugal impellers (without housing).

There are impellers with backward curved flat blades or with backward curved airfoil blades. The impellers are keyed with aluminium or steel hubs equipped with a keyway and tightening screws.

The impellers are coupled directly to the motor shaft, which is selected and sized, taking into account the starting inertia, the rated power absorbed and the rotation speed of the fan at the working point.





## EC Fan

These fans use electronically controlled motors, better known precisely as EC, capable of always working at maximum efficiency and allowing considerable energy savings, compared to traditional asynchronous motors (i.e. in alternating current). This technology makes it possible to integrate an extremely quiet and high-performance DC (direct current) motor on the AC (alternating current) fans, which allows a very precise adjustment of the speed, to obtain the required air flow, reducing the absorbed power. This simplifies the components necessary for these functions, compared to fans with traditional motors. The possibilities of controlling the fan speed are: 0 -10 V DC / 4-20 mA signal, PWM, or via the MODBUS serial RS485 communication protocol

### Main advantages of EC fans compared to conventional motors:

- Superior energy efficiency
- Lower operating costs
- Low noise level
- Precise speed control and adjustment
- Superior aeraulic performance
- Electronic protection integrated in the motor



## Accessories supplied with the fans

The control logics of the units involves the use of components designed to measure the pressure or air flow. Depending on the customer's selection, the following can be used: differential pressure switches, Magnehelic, Minihelic, pressure transducers to control fan air flow rate or pressure.



For safety reasons, it is also possible to select accessories, such as protection grids applied directly on the impellers or on the section inspection and disconnecting switches connected directly to the motor for any power outages.

# Filtering section

## Rigid bag filters



Rigid bag filters are made of wet-laid fibreglass, resistant to free moisture in the atmosphere. The material is manufactured with two layers: coarser fibres on the air inlet side and finer fibres on the outlet side. The two layers are glued to the sides of the cells using urethane sealant.

The dual-density design allows dirt particles to be collected for the entire depth of the package, exploiting the full filtering potential of the substrate and maximizing dust hold. Maximizing the ability to retain dust extends filter life and minimizes operating costs.

The thermoplastic separators maintain a uniform spacing between the folds to allow optimal air flow inside and through the filter. The separators also ensure a large effective medium area to minimize the pressure drop.

The sides of the filter head and cell are made of high impact polystyrene (HIPS). The design, which encloses a fixed media package, creates a robust filter that resists damage during shipping, handling and operation, with a space-saving design that reduces transport, storage and handling costs. All filter components are completely incinerable (maximum operating temperature 70°C). The available filtration levels comply with current European standards (ISO 16890).



## Soft bag filters;

Soft bag filters consist of a galvanized steel frame and a synthetic material as the filter medium. The maximum operating temperature is 70°C and they comply with the hygiene regulations in force.



## Compact filters

These filters are used both as prefilters and as main filters.

The filter cell frames are made of high impact polystyrene. All filter components are completely incinerable and non-corrosive (maximum operating temperature equal to 70°C). The hot melt separators maintain a uniform spacing between each curve to allow for optimal air circulation inside and through the filter. This filter is also available with fluids with bacteriostatic effect. The filter complies with the hygiene regulations in force (ISO 16890).



## Activated carbon filters

These filters are used for the deodorization and absorption of pollutants present in the air in civil and industrial air conditioning systems, where the control of gaseous pollutants is required. Activated carbon filters use micro-granules of activated mineral carbon. There are different types of treated granules with additives, suitable for the adsorption of specific gaseous substances. The supporting structure consists of a galvanized or stainless steel support plate, equipped with holes for the quick installation of the cartridge. The cylindrical cartridges are refillable, with expanded steel mesh and neoprene gasket on the connecting edge.



## HEPA filters

The filter medium used for these filters is folded water repellent fibreglass with constant calibration spacing. The separation of the layers takes place through continuous thermoplastic threads. The frame used is in galvanized steel, complete with side handles. A polyurethane sealant and one-piece gasket are also used to ensure a seal.



## Pre-filters for plate and rotary heat exchangers

The filter medium used for these filters is folded water repellent fibreglass with constant calibration spacing. The separation of the layers takes place through continuous thermoplastic threads. The frame used is in galvanized steel, complete with side handles. A polyurethane sealant and one-piece gasket are also used to ensure a seal.



## Accessories for filters

At the customer's request, it is possible to add accessory components to measure the clogging of the filter cells. For this purpose, the following can be selected: differential, Magnehelic, Minihelic pressure switches.



Other optional accessories are: the lamps (which can also be wired directly), the inspection doors equipped with polycarbonate portholes.



# Recuperators

The Professional units can be equipped with static or rotary heat recuperators, thanks to which considerable energy savings are obtained.

## Static plate heat exchangers

In static recuperators, the self-spaced thick aluminium sheets form the exchange pack. These sheets are suitably sealed to each other at the ends in order not to allow contamination of the replacement air by the exhaust air. The casing is made of galvanized sheet metal or aluminium. Usually plate heat recuperators are equipped with a bypass damper that excludes part or all of the external air from the recovery treatment.

## Rotary heat exchangers

The rotary heat exchangers are essentially made up of a rotating exchange pack, formed by thin sheets of pleated aluminium, enclosed in a frame also made of aluminium, galvanized steel or aluzinc. The casing panels are easily removable; this allows easy maintenance and cleaning. The rotor can be equipped with a regulator that allows to vary the number of RPM of the rotor and therefore the amount of heat exchanged.

## Static run-around recuperators

The run-around recuperators consist of two coils hydraulically connected in which the heat carrier fluid is water or glycol water, which transports the heat from the return air flow to the supply air flow or vice versa



Rotary recuperator



Static plate recuperator

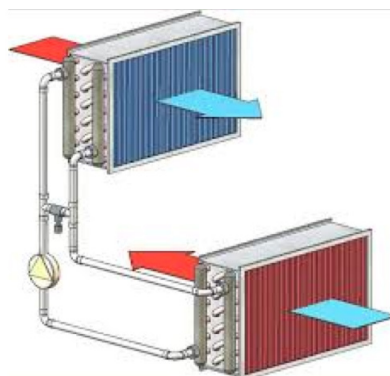

Static run-around recuperator

# Coils

The heat exchanger coils are used for heating the air with hot or superheated water or steam, or for cooling fed with chilled water, brine solutions, water and glycol mixtures or direct expansion. Alternatively, electric batteries can also be used where the air is heated by passing close to electrical resistances.

## Water and direct expansion coils

The water and direct expansion coils can be equipped with:

- Drainage tank in SS430, SS304 or SS316 stainless steel
- Two or three-way modulating valves
- Frost protection thermostat
- Plastic siphon DN40-32

## Electric heaters

Electric heaters can be equipped with a differential pressure switch hydraulically connected to the fan, for the battery activation logic, based on the flow of air that hits the battery.

# Humidification section

The air processed by the AHU can be humidified by means of:

## Steam isothermal humidification with distributors for network steam or self-produced with steam producers

The steam can be produced centrally with indirect steam generators, which produce sterile steam, transported with stainless steel pipes to the network steam distributors installed on board the unit.

The steam can be self-produced with steam producers with resistances or immersed electrodes. The former brings the water contained in the producer to boil, thanks to the heat provided by the resistances immersed in the water, while the operation of immersed electrode humidifiers is based on a very simple physical principle. Since common drinking water contains a certain amount of dissolved mineral salts, and is therefore slightly conductive, by applying a voltage to metal electrodes immersed in it, an electric current is obtained which heats it (Joule effect) until it boils, producing steam.

The amount of steam produced is proportional to the electric current, which is proportional to the water level.

The electric current is measured by an amperometric transformer.

Controlling the water level by means of the filling solenoid valve and the evaporation itself, the current and consequently, the production of steam is modulated.

Due to evaporation, the water level decreases and therefore the cylinder must be replenished.

Since the steam does not carry mineral salts, the water increases its salt concentration and therefore its conductivity, and is automatically and periodically diluted, discharging a part of it by means of the solenoid valve or the drain pump and replacing it with new water.

Compared to the humidifiers with immersed heaters or gas, to which they are complementary, the humidifiers with immersed electrodes:

- work with drinking water (not completely demineralized or softened);
- require periodic replacement (or cleaning) of the cylinder;
- have a modulation suitable for comfort or industrial applications without extreme requirements.

## Adiabatic water humidifier

The operation of the evaporating pack or of the nozzle system (washer or humidifier at low and high pressure) occurs through a natural process: the exchange of energy between water and air.

The pumping system placed on top of the pack uniformly wets the surface of the pack itself, while the systems with nozzles pulverize the water into tiny droplets.

When the water flows inside the humidifying pack or is nebulized, the energy required for the evaporation of the water is taken from the air that passes through the humidification system.

The air that passes through the pack or the humidification chamber provides the heat necessary for the evaporation process of the water itself.

For proper operation of the humidification system, the air must be suitably pre-heated, as in contact with the pack or with the nebulized water it cools in proportion to the increase in specific humidity.

## Dampers

The dampers consist of a frame and a series of galvanized steel or extruded aluminium blades. The damper control can be manual or motorized.

For the dampers there may be microswitches, positioned on the dampers themselves, capable of communicating the correct opening of these components before starting the machine. Alternatively, if there are motorized dampers on the machine, a timer allows the automatic stop (start) of the fan when the dampers are closed (opened).

According to the type of damper (with manual opening, motorized on/off, modulating), there are different types of actuators, which are shown in the figure below:





# Silencers

Silencers represent the standard solution for reducing the noise generated in the systems along the air ducts. The models used in the units are rectangular in shape.

Each splitter is made up of a double mat of non-combustible mineral wool, covered with a film of anti-erosion fibreglass.

The performance of the silencers is certified and compliant with the hygiene regulations in force. The option with removable silencers is available.

# UVC lamps

The emission of UVC lamps is used to inhibit the growth of fungi, bacteria, etc., in particular on the surfaces of the cooling coils, which, being wet, can create favourable conditions for the growth and proliferation of these pathogenic elements.

The presence of these lamps in the air handling units of Daikin Applied Europe S.p.A. brings the following benefits to the system:

- Reduces the energy costs of air conditioning and ventilation systems, as it keeps the exchange surfaces clean, leaving the heat transfer unchanged.
- The use of UVC germicidal rays is effective as an inactivation method for viruses, bacteria and moulds.
- Allows to reduce or eliminate expensive cleaning and sanitizing programs, through the use of harmful substances, chemicals and disinfectants, programs that must also be implemented for the disinfection of the coils, condensate collection trays, plenums and ducts.
- Does not produce appreciable ozone or secondary contaminants.
- Improves the indoor air quality of buildings (IAQ).

The UV lamps section is equipped with an electrical panel. The wiring diagram is delivered together with the unit and shown below, dedicated both to the power supply of the lamps and to the connection of the auxiliary safety components (inspection door microswitch in the UV lamp section and pressure switch with flow switch function).

The intervention of these elements causes the immediate shutdown of the lamps in the event of the supply fan being stopped or in the event of accidental opening of the inspection door of the UV lamp section.

It is the responsibility of those who carry out the first start -up to fill in the fields on the label applied to the UV lamp section below:

**DAIKIN**

**▲ WARNING - AVVERTENZA - WARNUNG**

**EN UVC EXPOSURE HAZARD**  
 -Always turn off power to UVC lights before servicing or repairing. -This unit contains high energy ultraviolet C-band (UVC) germicidal lamps, which can cause serious temporary eye and skin irritation. -Never expose unprotected eyes or skin to the UVC light from any source. -Always wear face shields or goggles. Must comply with applicable regulations.

**IT RISCHIO DI ESPOSIZIONE AI RAGGI UVC**  
 -Togliere sempre l'alimentazione alle lampade UVC prima di svolgere attività di assistenza o riparazione. -Questa unità include lampade con azione germicida (UVC) a elevata energia a luce ultravioletta nella banda UV-C, che possono provocare una temporanea grave irritazione oculare e cutanea. -Non esporre mai occhi e pelle non protetti alla luce UVC proveniente da qualsiasi sorgente. -Indossare sempre visiere oppure occhiali di protezione che devono essere conformi alle normative di riferimento.

**DE UV-C-EXPOSITIONSGEFAHR**  
 -Trennen Sie die UV-C-Leuchten vor Instandhaltungs- oder Reparatureingriffen stets von der Stromversorgung. -Dieses Gerät enthält keimabtötende Hochenergie-Lampen mit ultraviolettem Licht im C-Bereich, die ernsthafte vorübergehende Augen- und Hautreizungen verursachen können. -Setzen Sie Augen oder Haut nie ungeschützt UV-C-Licht jeglicher Quellen aus. -Tragen Sie stets Gesichtsschutzschild oder Schutzbrille. Muss den Referenznormen entsprechen.

INSTALL DATE DATA DI INSTALLAZIONE INSTALLATIONSdatum	EMITTER MODEL # MODELLO EMETTITORE N. STRAHLERMODELL #	FIXTURE MODEL # MODELLO APPARECCHIO N. HALTERUNGSMODELL #
<b>CHANGE DATE - DATA MODIFICA - ÄNDERUNGSDATUM</b>		

AHABSTICKER0060

Before installing the lamps, check that the support structure is intact and that it has not been damaged during transport.

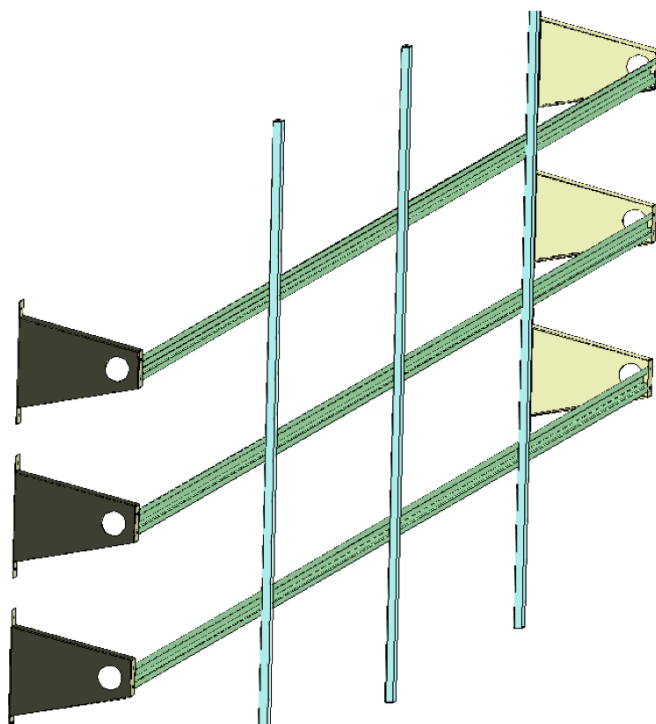

## Wiring diagram for the connection of UV lamps (panel supplied and wired)

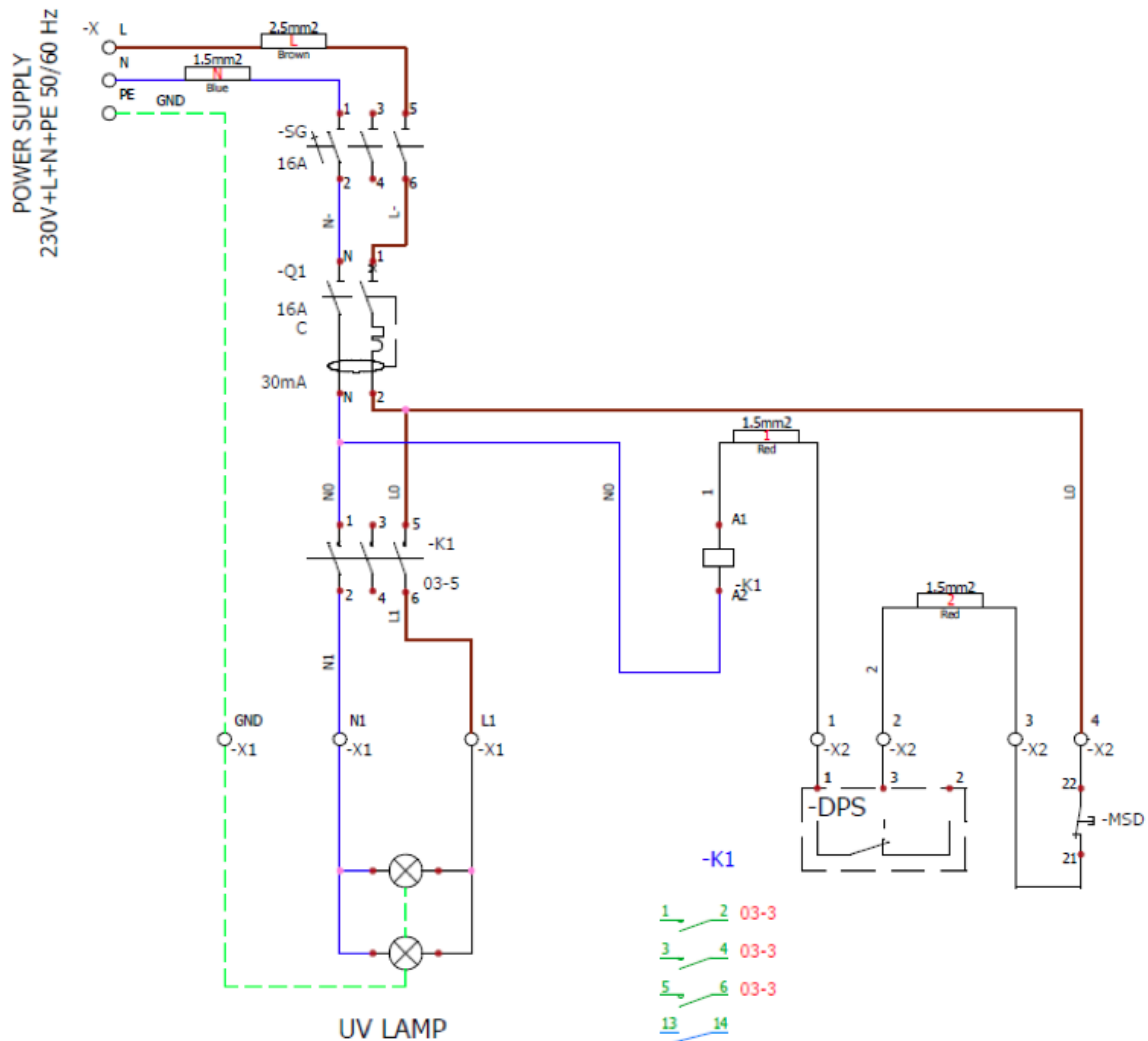

Key:

SG = general disconnecting switch (16 A)

Q1 = Differential circuit breaker (16 A - 0.03 A)

K1 = lamp ignition contact relay

DPS = Differential pressure switch with flow switch function

MSD = Microswitch for inspection of the UV lamp section.

The lamps must be replaced after 9,000 hours of operation and the replacement must be recorded on the label shown above.

# 3 Receiving of the packages



Handle the equipment following the Manufacturer's instructions on the packaging and in this manual. Always use personal protective equipment.

The means and method of transport must be chosen by the transport operator according to the type, weight and size of the machine. If necessary, draw up a "safety plan" to guarantee the safety of the people directly involved.



At the moment of receiving the machine check the integrity of the packaging and the amount of parcels sent:

- A) There is visible damage/one or more packages is missing: **do not** install, but **promptly** notify the Manufacturer and the carrier that made the delivery.
- B) There is NO visible damage: move the machine to the site of installation.

**N.B.:** The packaging is guaranteed for a period of 6 months from the date of manufacture of the same (indicative label placed on the packaging). The company will not be held responsible for any damage due to oxidation or rust formation on any part or component of the unit, after this period. The 6-month warranty is in any case subject to the perfect state of conservation of the wrapping constituting the packaging.

## Read the packaging symbols

Externally, the packaging bears all the information necessary to transport the equipment safely: compliance with these instructions ensures operators are safe and prevents any damages to the equipment.

The figure shows the symbols applied to the packaging:



Indicates top and bottom



Indicates that the package must be stored in a dry place because its contents are sensitive to humidity



Shows that the package must be handled with care because its contents are fragile



Shows the package's centre of gravity



Shows the position of the cables so that the package can be lifted correctly





Shows the maximum weight that can be placed on top of the package





# 4 Transport



During the lifting and transport phases there are risks associated with:

-  Operations on the machine by unqualified, untrained, uninformed or improperly equipped personnel.
-  Incorrect choice or incorrect use of the means of transport and handling (for example, crane, hoist, forklift truck) of the machine components;
-  crushing of handling operators;
-  loss of load stability during transport and handling operations;
-  projection of moving parts of the machine that cannot be removed or fixed properly;
-  collisions of parts or components of the machine with people or objects due to unexpected movements of the machine itself or incorrect behaviour by the operators responsible for the operation;
-  impact or fall of machine components, with damage to the machine itself and its protections;
-  unhealthy positions or excessive efforts for the operators assigned to transport and handling the machine components.
-  Packages can be handled with a lifting hook or pallet truck of suitable capacity. The choice of the most suitable means and method lies with the operator.
-  The operating area must be perfectly free from objects or people not involved in the transport.
-  If the unit is moved using hooks, use some spreader bars between the lifting cables to prevent damage to the unit and ensure no excessive stress is placed on the side panels.

## Lifting

-  Never use two lifting devices at the same time.
-  Never stand under suspended loads.
-  If steel ropes are used, always apply the end eye to the lifting hook.
-  When using steel ropes, be careful not to create sharp bends, i.e. with a radius of curvature smaller than that of the rope end eyelets.
-  Use ropes of adequate length, so that the angle between the ropes and the horizontal plane is always  $\geq 75^\circ$  (angle between the ropes  $\leq 30^\circ$ ).



If lifting eyebolts are provided, the end shackles of the ropes must be screwed by hand and turned in their direction of work.

## Lifting using hooks



Use hooks of adequate capacity and material for the weight of the packaging to be lifted. Make sure that the safety latch is in the correct position while lifting.



DO NOT handle the equipment if the field of vision is poor or in the presence of obstacles along the way (e.g. electrical cables, lintels, etc.) When the loads are lifted, the range of action of the lifting equipment must remain free of persons.



Use perfectly serviceable hooks, chains or steel cables of adequate capacity and material, without any joints or extensions. To guarantee efficiency, carry out periodic checks.



Make sure the ground the lifting equipment rests on is stable and not subject to subsidence. Check the flatness of the ground. Do not move the lifting device with the machine suspended in the air.

### Lifting with ropes

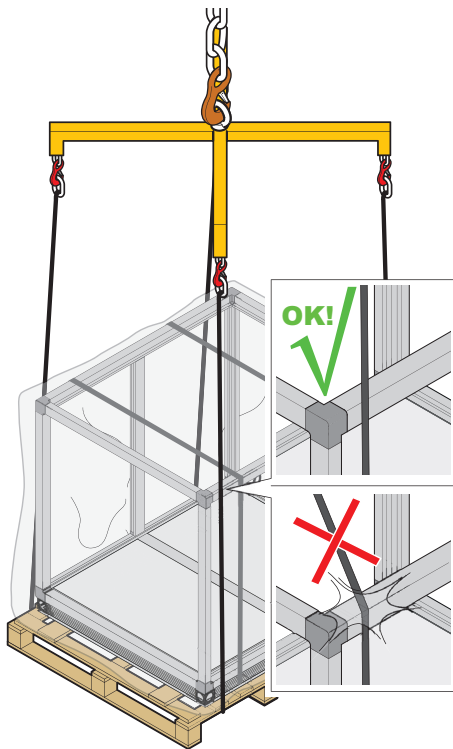

### Lifting with eyebolts

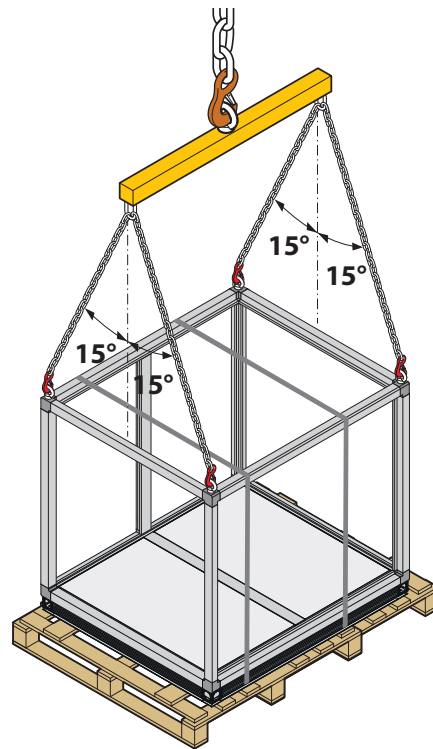

### Lifting with bracket + hook

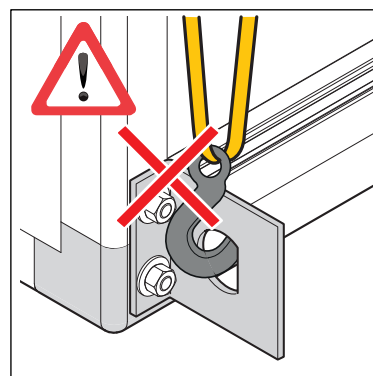
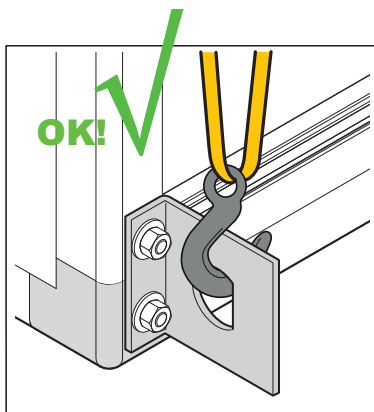

**P400** Lifting system

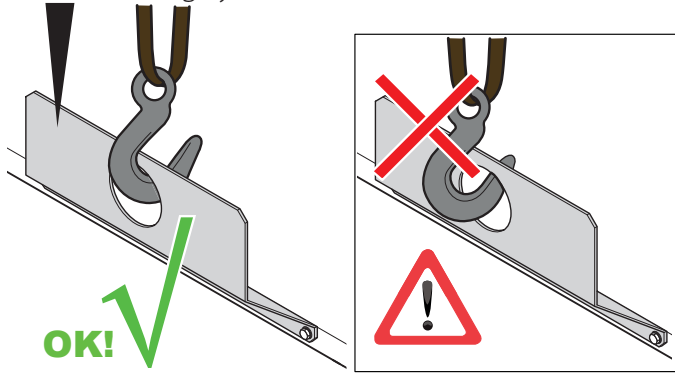

Lifting system

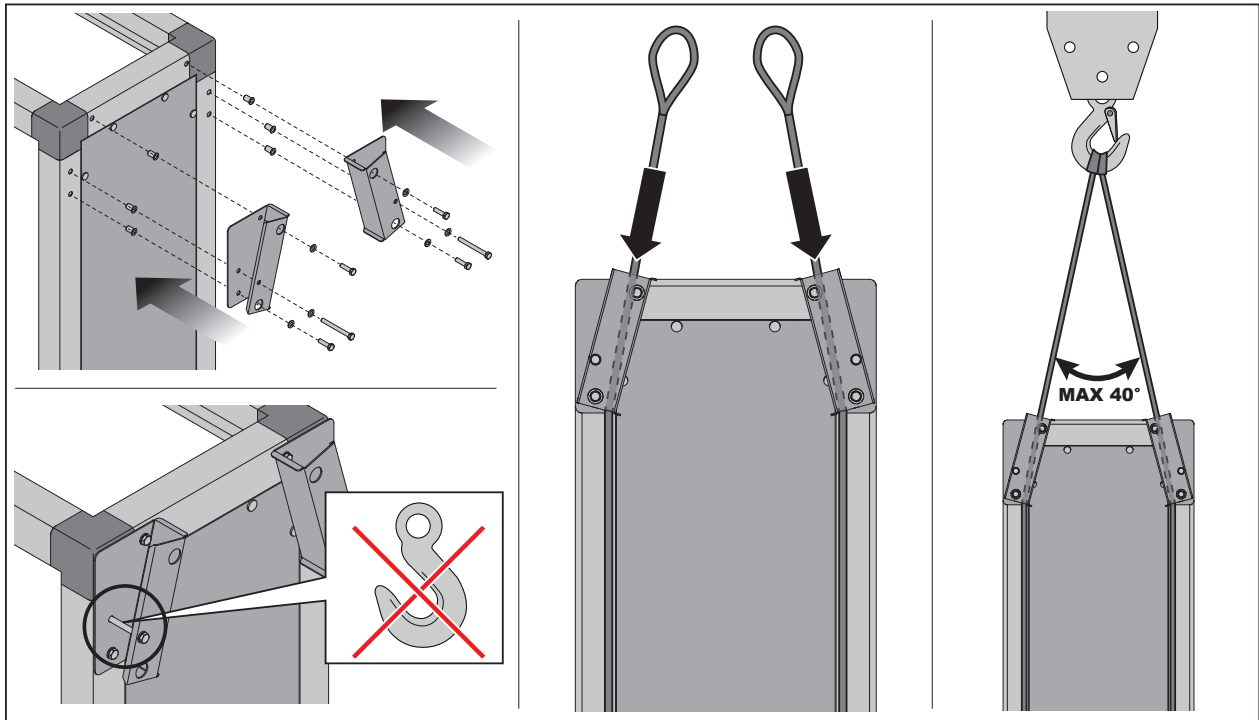
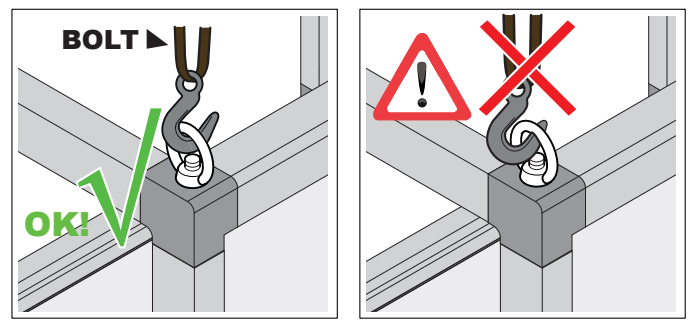

To lift the rotary recuperators, where present, use the plates positioned in the upper part of the section, as guide for the roll-over ropes.

**N. B.: Do not use the rope guide plates to lift the section for any reason and strictly follow the instructions given in the illustrations.**



Before lifting it, check the position of the centre of gravity and that the equipment is correctly anchored to the lifting points provided, then slowly lift the package to the minimum height necessary and move it carefully to prevent any dangerous vibrations.



Avoid sudden stops while lifting or lowering the package, to prevent any dangerous oscillations.

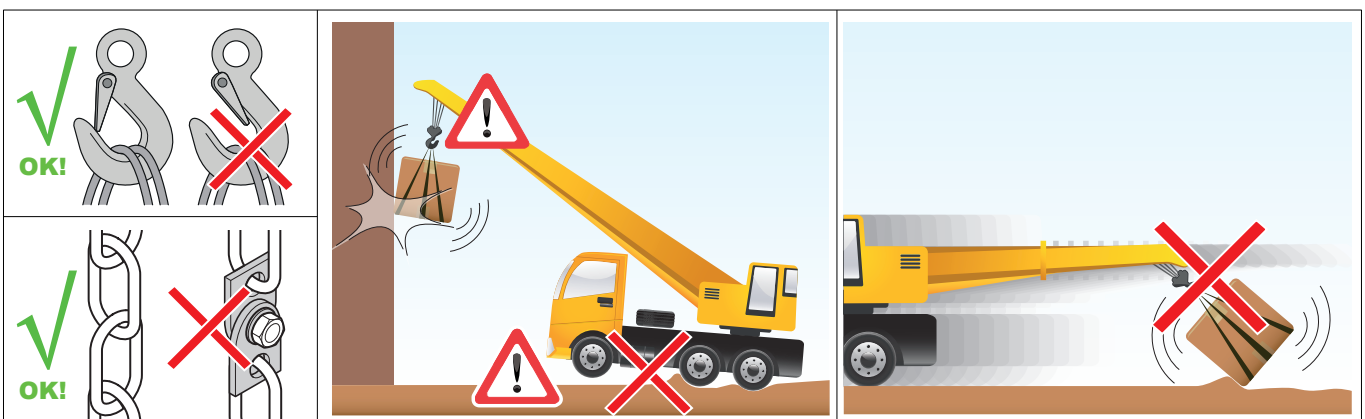

## Lifting using a pallet truck



If transport is done using a pallet truck make sure it is suitable for the weight and size of the machine. Insert the forks into the points provided for handling (usually in a central position) so as to keep the centre of gravity of the load in balance. Move the equipment carefully, avoiding sudden movements.

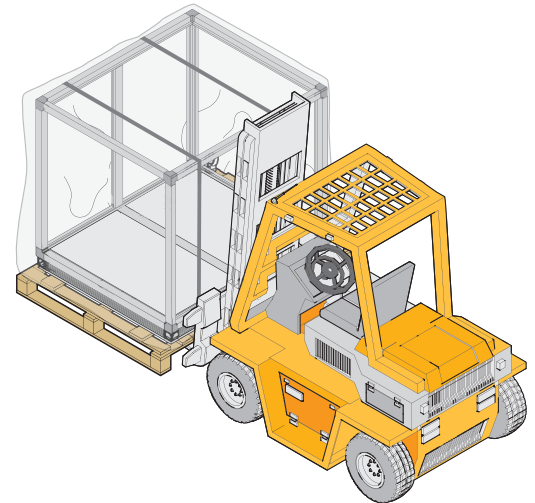

## Lifting non-palletised equipment

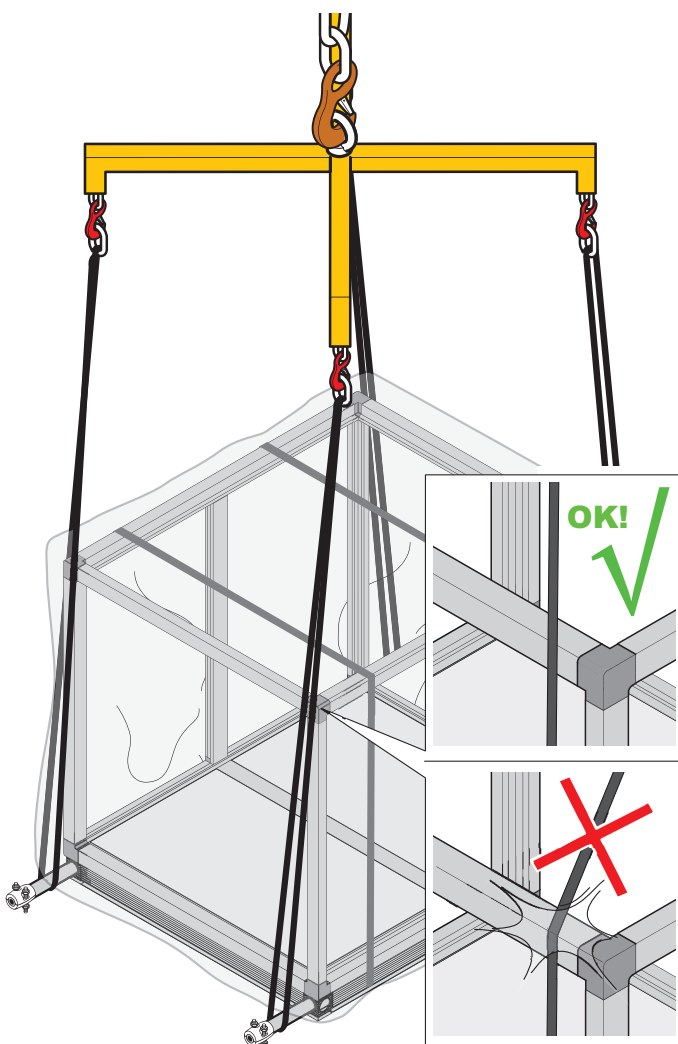

The equipment must be lifted using tubes (not supplied) inserted into the holes provided on the apparatus ( $\varnothing$  holes = 60 mm).



The type and diameter of the lifting tubes depend on the weight of the machine to handle. It is the transport operator's responsibility to make the right choice.

Use steel tubes that are in good condition and undamaged.



The ends of the lifting tubes must be closed mechanically to prevent them from coming out of the holes provided.



Position the lifting ropes as shown in the figure, in the part of the tube nearest the equipment.

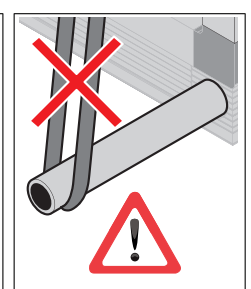
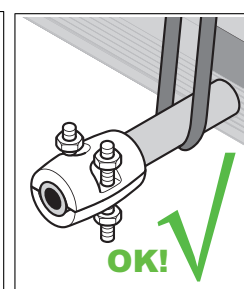
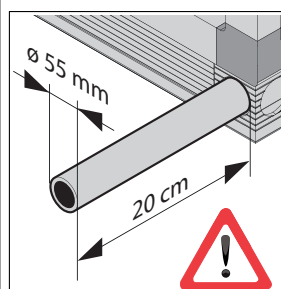
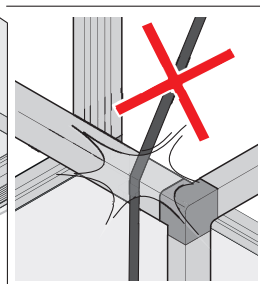
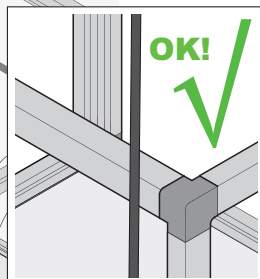



# 5 Unpacking and verification of integrity

We recommend the equipment be unpacked after moving it to its installation location and only when it is to be installed. This operation must be performed using personal protection equipment (i.e., gloves, safety shoes, etc.).



Do not leave the packing unattended: it is potentially harmful to children and animals (suffocation hazard).



Some packing materials must be kept for future use (wooden crates, pallets, etc.), while those that cannot be reused (i.e., polystyrene, strapping, etc.) must be disposed of in compliance with the regulations in force in the country of installation: this will protect the environment!

## After unpacking

After unpacking, check the integrity of the machine and any additional modules.

In case of damaged or missing parts.

- **Do not move, install or repair** damaged components and the machine in general.
- **Take quality photos** to document the damage.
- **Find the serial number plate** on the machine and note the machine's serial number;
- Immediately **notify** the carrier that delivered the machine;
- **Promptly** contact the Manufacturer (keep on hand the serial number of your machine).



Please note that complaints or claims of damage reported after 10 days of receipt of the machine cannot be accepted.

### MANUFACTURER INFORMATION:

DAIKIN APPLIED EUROPE S.P.A.

Via Piani di Santa Maria, 72 - 00040 Ariccia (Roma) - Italy

Tel: (+39) 06 93 73 11 - Fax: (+39) 06 93 74 014

<http://www.daikinapplied.eu>

**DAIKIN**

AHU Grandezza Size **C** Rif.to Ref. **D**

Matricola Serial number **I** Data Date **E** **CE**

PORTATA ARIA / AIR FLOW **B**

Mandata Supply Fan **F** m<sup>3</sup>/h Ripresa Return Fan **G** m<sup>3</sup>/h

Corrente / Current **H** Ter

MESSA IN FUNZI  
All'avviamento consul  
operativo e controlla  
1) senso di rotazione  
2) l'assorbimento del  
superare il valore

**A** Via

- A:** Manufacturer's name and data
- B:** CE markings
- C:** Machine size
- D:** Unit reference in the order
- E:** Date of manufacture
- F:** Supply airflow rate
- G:** Delivery airflow rate
- H:** Electrical specifications (frequency, number of phases, absorption in plate conditions)
- I:** Machine serial number

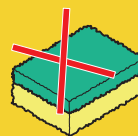
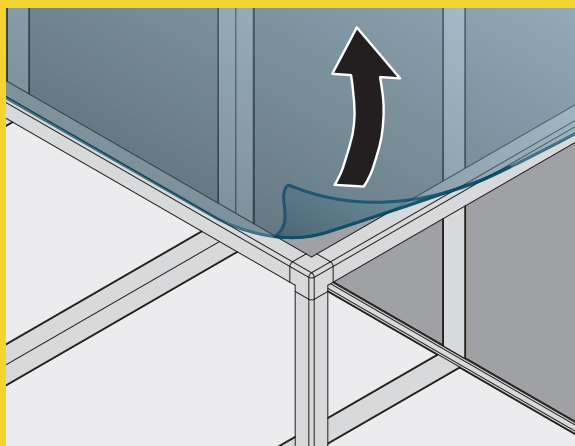

It is important to remove **IMMEDIATELY** the protective film on both the sides and the top



# Reading the serial number plate

## Identification

AHU Grandezza Size	<input type="text"/>	Rif.to Ref.	<input type="text"/>
Matricola Serial number	<input type="text"/>	Data Date	<input type="text"/>
PORTATA ARIA / AIR FLOW			
Mandata Supply Fan	<input type="text"/> m <sup>3</sup> /h	Ripresa Return Fan	<input type="text"/> m <sup>3</sup> /h
Corrente / Current	<input type="text"/>	A	
Tensione / Voltage	<input type="text"/>	400V/3/50Hz	
<b>MESSA IN FUNZIONE</b>		<b>START UP</b>	
All'avviamento consultare il manuale operativo e controllare:		Before the start up read carefully the operating instruction manual and check:	
1) senso di rotazione del ventilatore		1) fan rotation direction	
2) l'assorbimento del motore, il quale non deve superare il valore di targa sopraindicato		2) the current input must not exceed the value mentioned on the above tag	
<b>DAIKIN APPLIED EUROPE S.p.A.</b> Via Piani di S. Maria, 72 00040 Ariccia – (ROMA) IT MADE IN ITALY			

AHU Grandezza Size	<input type="text"/>	Rif.to Ref.	<input type="text"/>
Matricola Serial number	<input type="text"/>	Data Date	<input type="text"/>
PORTATA ARIA / AIR FLOW			
Mandata Supply Fan	<input type="text"/> m <sup>3</sup> /h	Ripresa Return Fan	<input type="text"/> m <sup>3</sup> /h
Motore Motor	<input type="text"/> Kw	A	
Motore Motor	<input type="text"/> v		
<b>MESSA IN FUNZIONE</b>		<b>START UP</b>	
All'avviamento consultare il manuale operativo e controllare:		Before the start up read carefully the operating instruction manual and check:	
1) senso di rotazione del ventilatore		1) fan rotation direction	
2) l'assorbimento del motore, il quale non deve superare il valore di targa sopraindicato		2) the current input must not exceed the value mentioned on the above tag	
<b>DAIKIN APPLIED EUROPE S.p.A.</b> Via Piani di S. Maria, 72 00040 Ariccia – (ROMA) IT MADE IN ITALY			

For a quick identification of the control unit, just refer to the data shown on the CE plate, placed on the external panelling of a section of the control unit (generally the supply fan section), such as the one shown in the figure, which briefly contains the following characteristics:

- 1) Manufacturer's name and address
- 2) CE mark
- 3) Size of the control unit with serial number
- 4) Unit reference in the order
- 5) Date of manufacture
- 6) Supply airflow rate
- 7) Return airflow rate
- 8) Main supply voltage
- 9) Frequency
- 10) Number of phases
- 11) Total electrical current absorbed (in rated conditions)

Further additional information, both of a constructive and of a performance nature, is however shown in the specific graphic and technical drawings delivered together with the unit and also attached to this manual.

# Storage waiting for installation

Waiting for the installation, the components of the machine and the relative documents must be stored in an area that:

- Is dedicated exclusively to the storage of the components.
- Is covered and protected from the weather (preferably prepare a closed area), with adequate temperature and humidity.
- Is accessible only to operators tasked with the assembly.
- Can support the weight of the equipment (check the load rating) and has a stable floor.
- Is free from other components, especially if they are potentially explosive/incendiary/toxic.



If you cannot proceed with the installation straight away, check periodically that the above-mentioned conditions about the storage area are guaranteed.

# 6 Installation



All installation, assembly, electrical connections to the mains and extraordinary maintenance must be performed **only by qualified personnel authorised by the Retailer or Manufacturer**, in compliance with the regulations in force in the country the equipment is to be used and the standards on the systems and safety in the workplace.



During installation, the area must be free from people and objects not used for the assembly.



Any movement carried out after unpacking must be done with the doors closed. Do not move the units by pulling on the doors, if present, the uprights or other protruding parts that are not an integral part of the structure.



Do not step on the units!



Before starting, make sure you have all the necessary equipment. Use only equipment that is in good condition and undamaged.



There are two different types of hook, refer to the assembly instructions for the one in your possession.



Before starting, make sure you have all the necessary equipment. Use only equipment that is in good condition and undamaged.

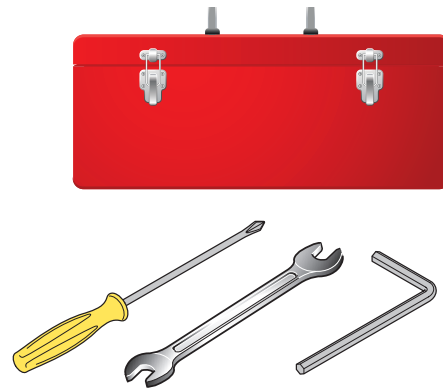

Before proceeding with the installation of the machine, it is necessary to prepare the power supplies and utilities necessary for the correct operation of the system and, if required, consulting in advance with the Manufacturer's Technical Office.

The machine does not require special environmental conditions for its operation. For a correct installation it is sufficient to prepare a level support surface, indispensable for the correct operation of the machine and to guarantee the regular opening of the inspection doors.

The altitude of the installation room must be less than 1,000 meters above sea level (at higher altitudes the electric motors deliver powers lower than the nominal ones).

The installation in the workplace must be done in such a way that the machine and its equipment are accessible to allow it to start, stop and carry out maintenance work on the machine.

For the choice of location, in general, care must be taken that an operator can move around the machine without hindrance. The minimum distance to the nearest wall must in any case be at least equal to the width of the machine.

Where there are no means of transport to move the machine, its positioning must take into account the free space required for any repairs. It is of course necessary to plan enough space for regular operation, as well as for machine maintenance, including all the space for any peripheral equipment.

To operate the machine requires:

- Electrical connections;
- Water connection;
- Air duct connection.

## Installation procedure

Before installation, read the safety instructions on the first pages of this manual. Contact the Manufacturer if any points are unclear or not perfectly understandable. A check mark next to each step will help to confirm complete and proper installation.

<input type="checkbox"/>	Step 1: Position the unit.....	page 38
<input type="checkbox"/>	Step 2: Section coupling procedure .....	page 39
<input type="checkbox"/>	Step 3: Fasten the units to the ground (optional) .....	page 43
<input type="checkbox"/>	Step 4: roof assembly procedureroof assembly.....	page 45
<input type="checkbox"/>	Step 5: Make the connections .....	page 48
<input type="checkbox"/>	Step 6: Perform a trial run .....	page 74

After installation store this manual and the assembly sheet that accompanied the machine in a place that is dry and clean. This way it will be accessible to operators in the future who need to consult it. Do not remove, tear out or write on any part of this manual besides the space set aside for notes:

<b>Installer/maintenance notes</b> <hr/> <hr/> <hr/> <hr/> <hr/> <hr/> <hr/> <hr/>
---

## Step 1: Position the unit

Check that a suitable **base** has been prepared (fig. 1) for the support and installation of the machine. It must be stable, perfectly flat, made of reinforced concrete and have the capacity to support the weight of the machine.



For the size of the base and the weight to be supported, refer to the executive drawing delivered when the machine was ordered.

The installation site must also include (fig. 1):

- Suitable **drainage** to convey and drain the water in case of accidental breakage of pipes that carry the fluids to the machine.
- An **electrical system** compliant with current regulations and with specifications that meet the needs of the machine;
- A **water/gas connection** (in the case of connection to coils supplied by water or gas).
- A drain pipe with **drain siphon** connected to the sewerage system.
- an **aeraulic system** (ducts for the air to be conveyed to the environments).

Position the unit above the base. Make sure that the area chosen for the placement has **sufficient space** to allow for subsequent installation and maintenance all around the unit (including replacement of any internal components, for example the removal of heat exchange coils, filters, etc.) (fig. 2 indicates the minimum distances to be maintained). It is advisable to check the extraction side of the components before installing the machine.



Warning! The machines were designed to operate in technological spaces or outdoors. They **CANNOT** operate in environments with explosives, where there is a high presence of dust, high humidity or high temperatures unless specific modifications are requested during production.

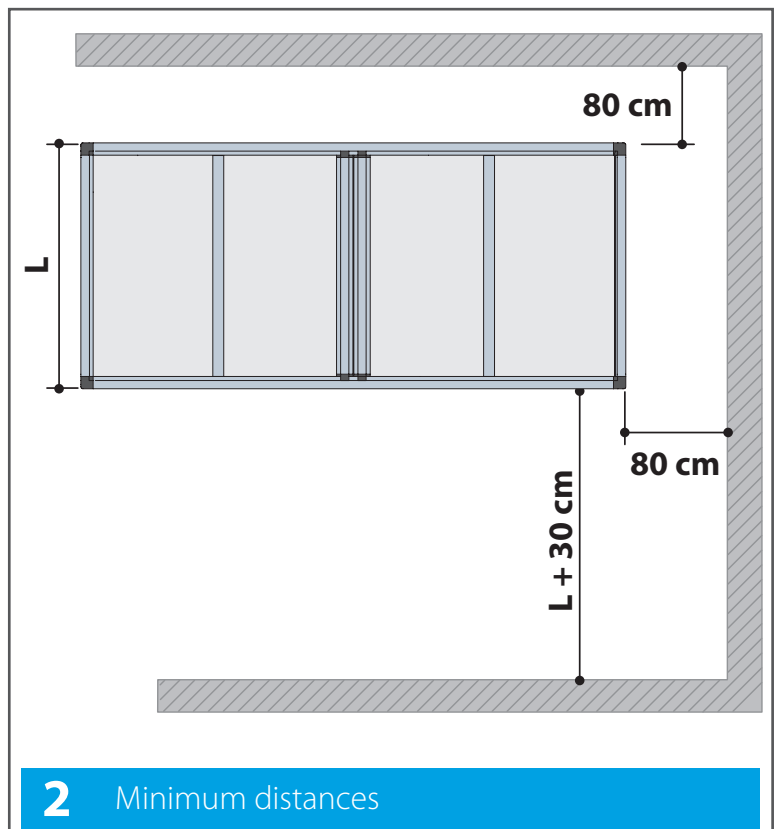
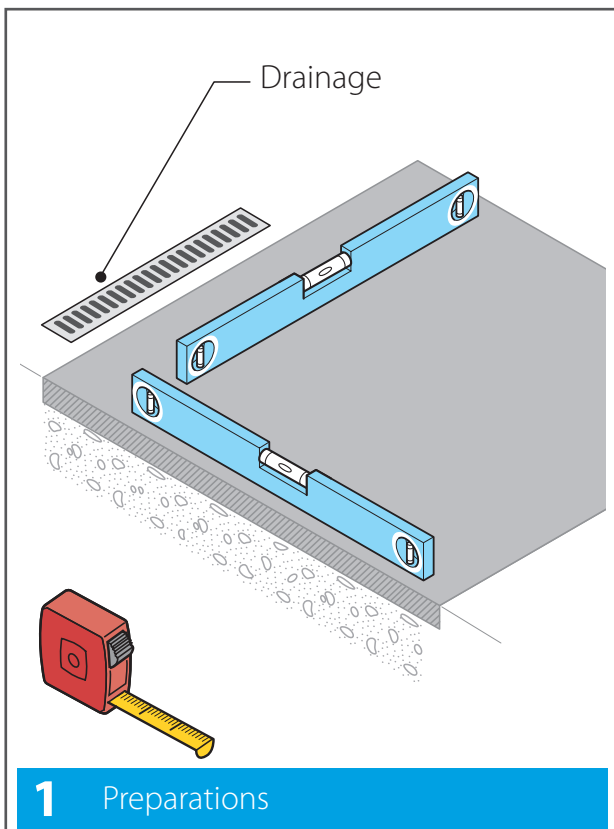

The acceptance criteria for the flatness of the air handling unit are defined by the following points:

- It is mandatory to ensure that the doors can be opened. Any interference between the door and the profile will be avoided with the correct levelling, by inserting metal plates between the base of the section and the ground.
- The flatness of the AHU support surface will be checked as in point 1 above along the entire perimeter of the AHU. On the sides without doors, non-coplanarity of a maximum of 2\*mm/m is allowed

\*In case of non-flatness of the ground, there may be misalignment between different sections

## Step 2: Section coupling procedure

Before installation, read the safety instructions on the first pages of this manual. Contact the Manufacturer if any points are unclear or not perfectly understandable.



Gently join the sections after attaching the adhesive seal supplied with the machine on the whole perimeter of contact, just on one side.



**The drawings on the following pages represent a generic and stylised unit, however the connection procedure is the same for all types of units.**

For the installation of a monobloc air handling machine it is only necessary to place it on the support surface and level it, possibly with the help of suitable shims. In the case of an air handling machine consisting of several sections, the following procedure must be adopted, bearing in mind that gaskets in rolls, threaded bars, nuts and washers for the assembly are supplied together with the sections.

1

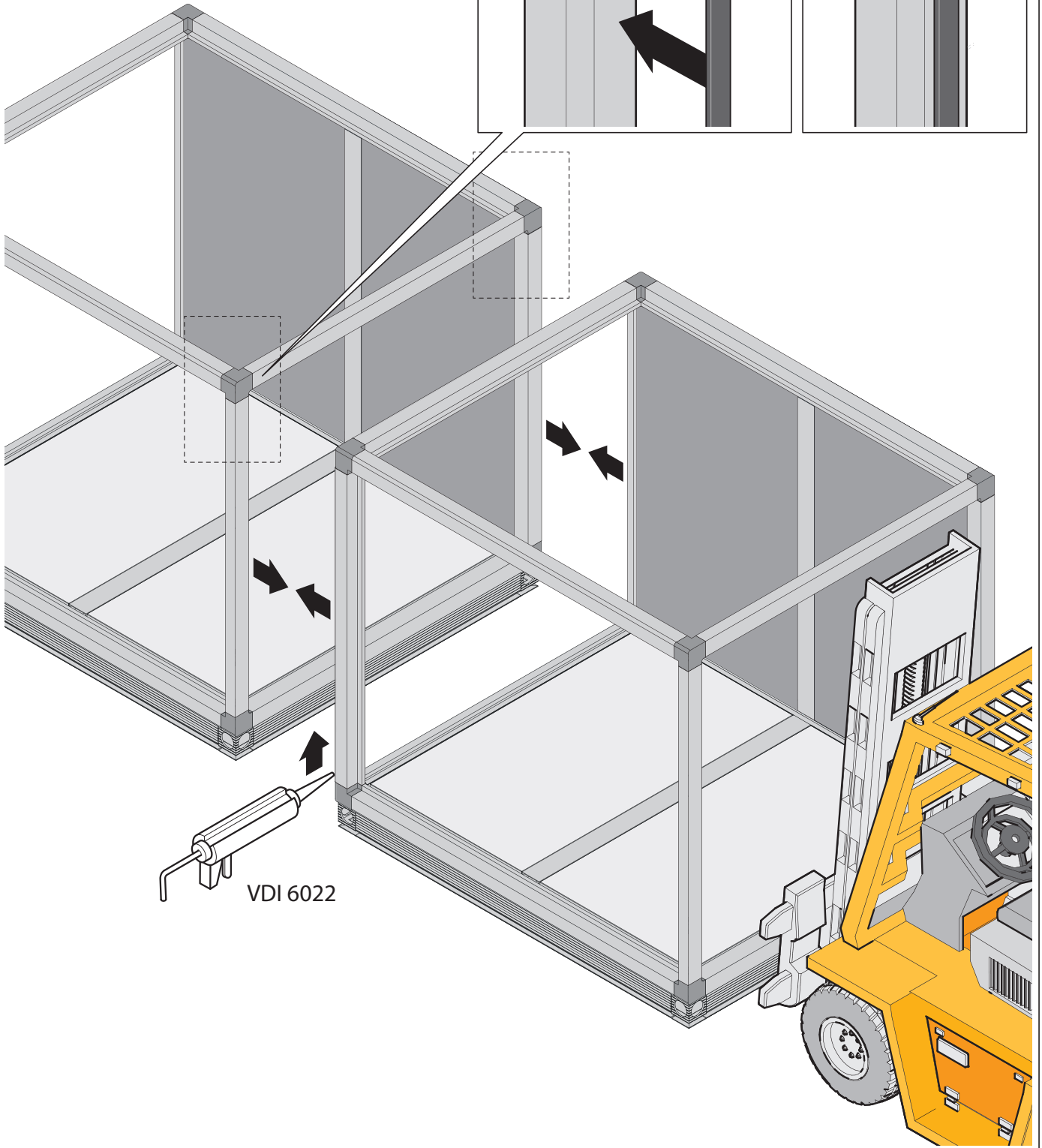
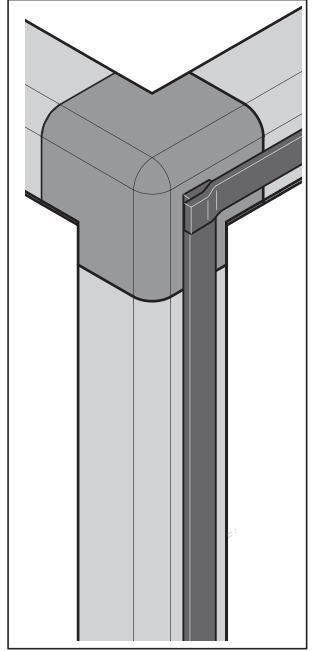
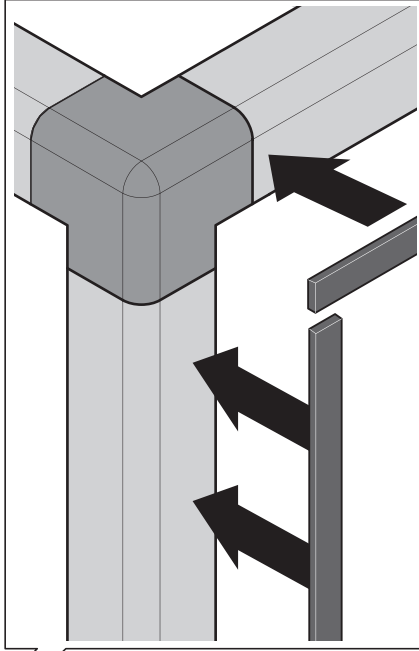
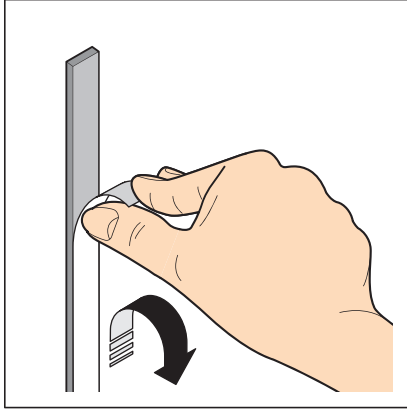



2

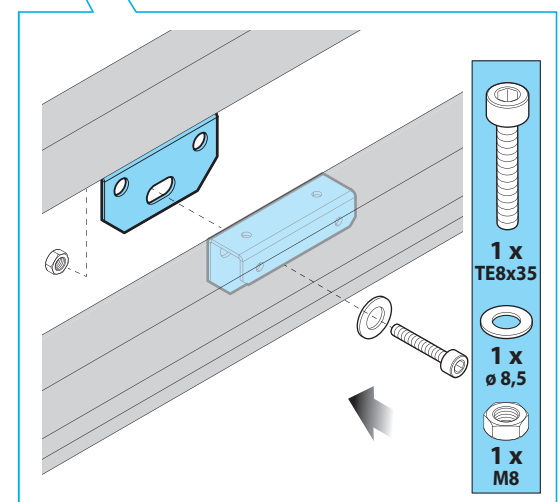
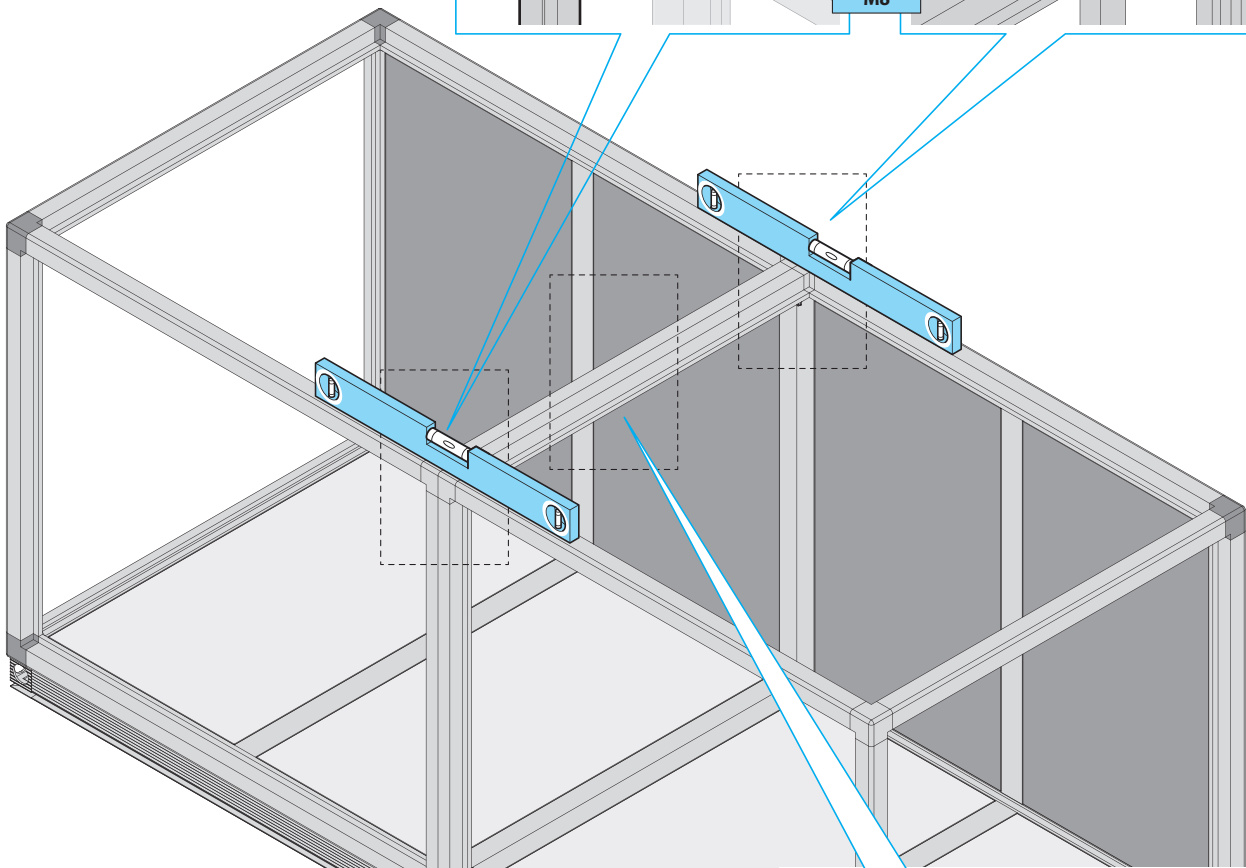
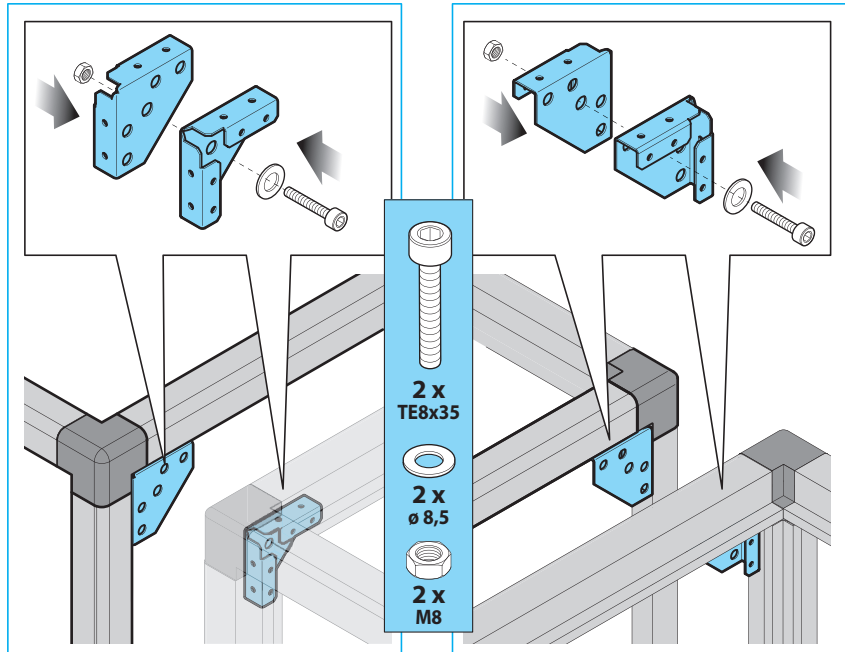



After installation, the following conditions must be met:

- The difference in height of the support base and consequently of the machine can be 1 mm per meter max.
- The height difference over the entire length and width of the machine can be 5 mm max.

If these conditions are not met due to uneven or yielding foundations, appropriate measures must be taken (e.g. spacers of appropriate thickness).

Warning! If these structural conditions are not met, there may be difficulties in opening the doors and dampers and other types of problems with the machine.

**3**

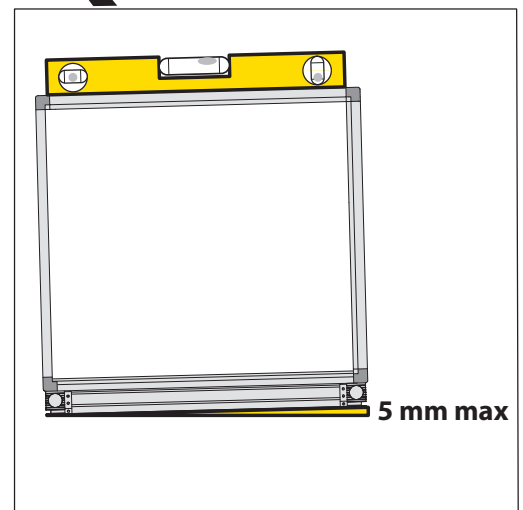
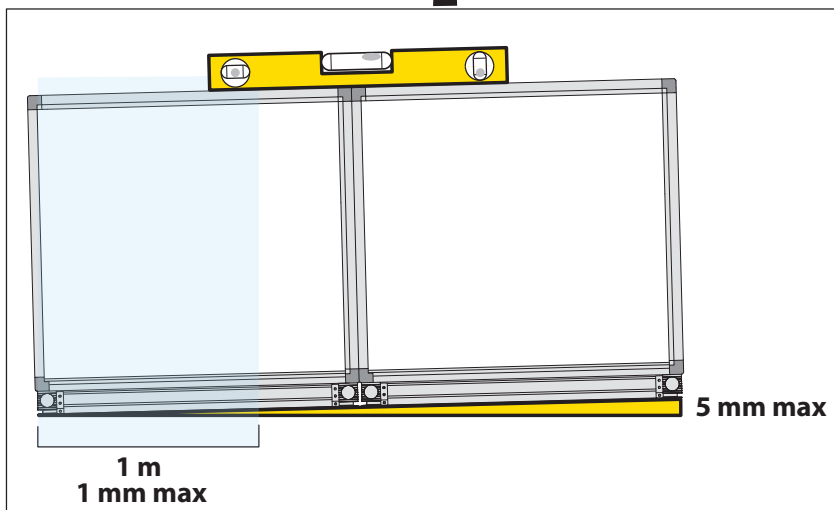
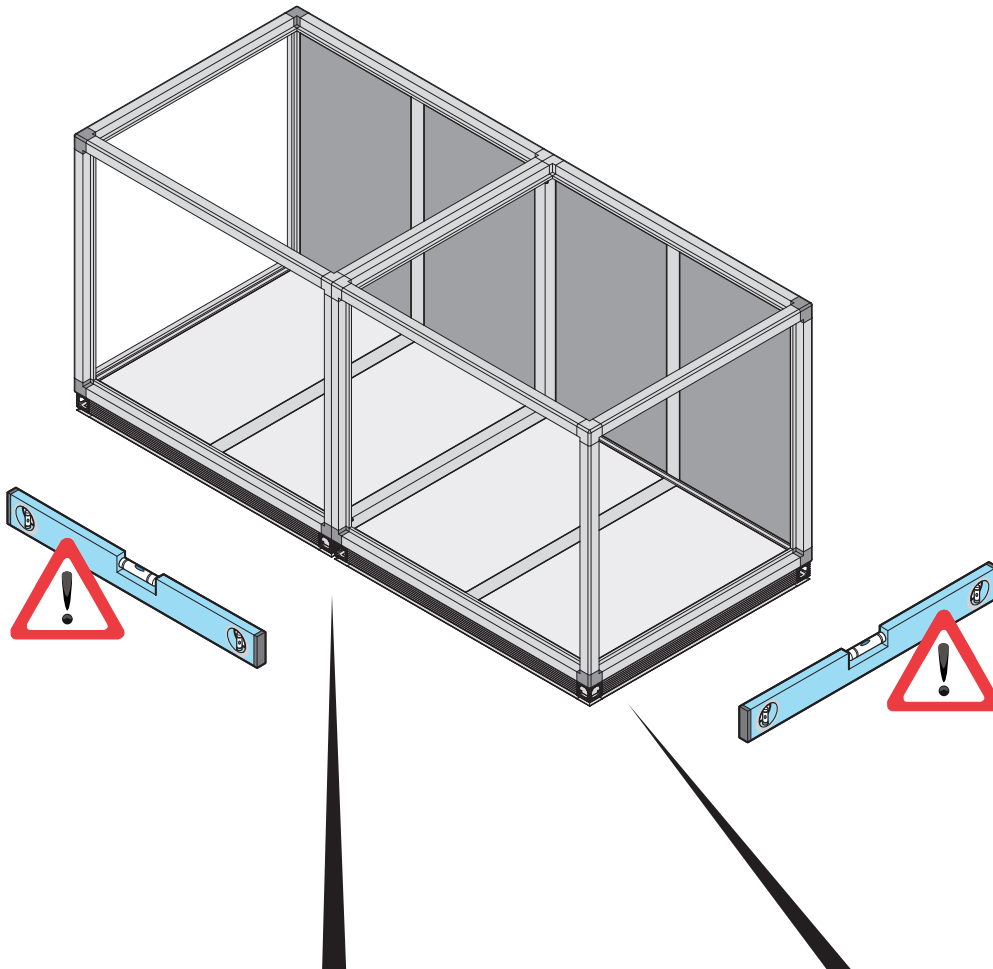



After installation store this manual and the assembly sheet that accompanied the machine in a place that is dry and clean. This way it will be accessible to operators in the future who need to consult it.

### Step 3: Fasten the units to the ground (optional)

After positioning the units, make sure they are perfectly level, if necessary inserting suitable solid and stable shims under the supports.

Finish by fastening them to the ground (tools and fastening components not included). The installer is responsible for choosing the most suitable means of fastening based on experience (the drawing includes an example).



There is no need to insert vibration damping material between the machine and the ground as the moving internal parts transmit no residual vibrations to the outside.

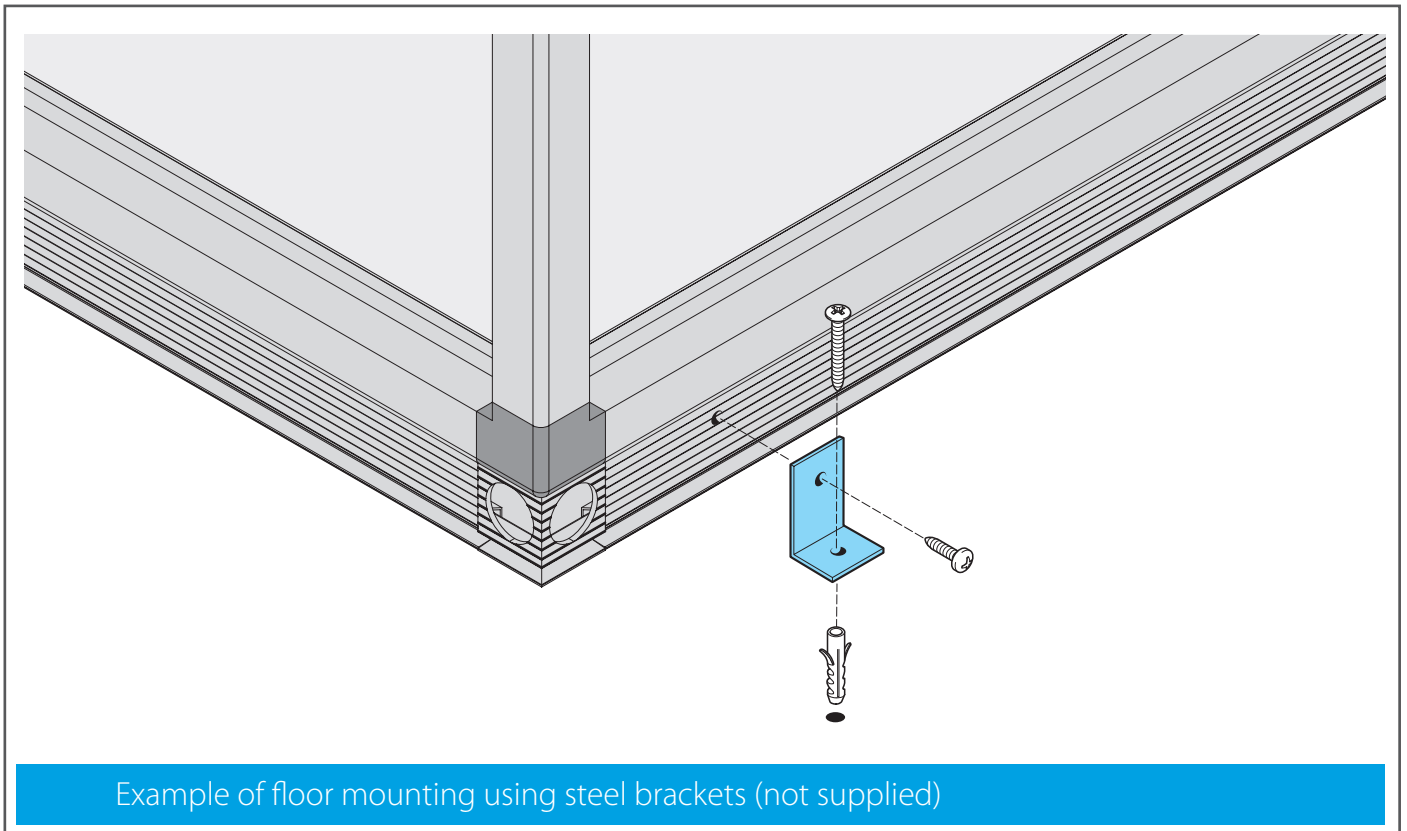



## Step 4: roof assembly procedure

The roof shapes for Daikin air handling units are as shown in the figure below

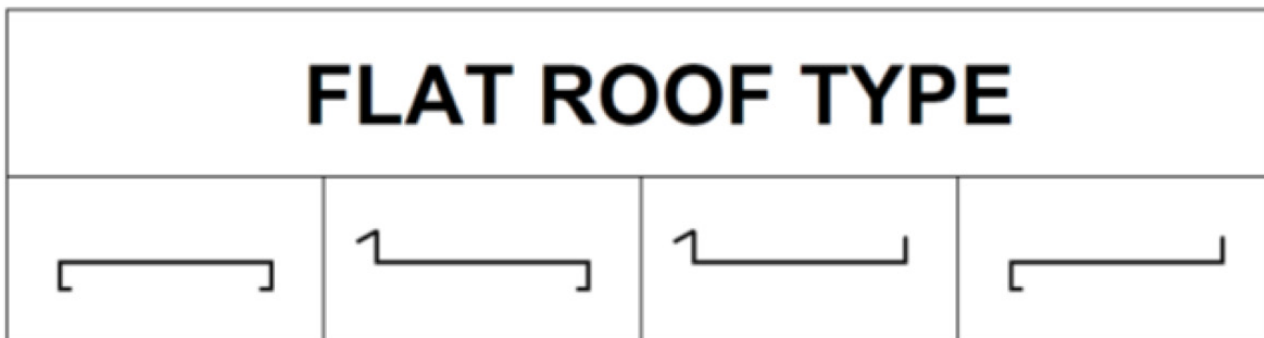

The type below is totally installed at the factory.



The installation of the roofs indicated below is the responsibility of the installer.



The joints between the metal sheets of the roof will be properly joined and sealed with silicone or similar (not supplied with the air handling unit) and firmly fixed with the supplied bolts.

The sealant will be suitable for outdoor installation, resistant to UV rays, anti-mould and waterproof.

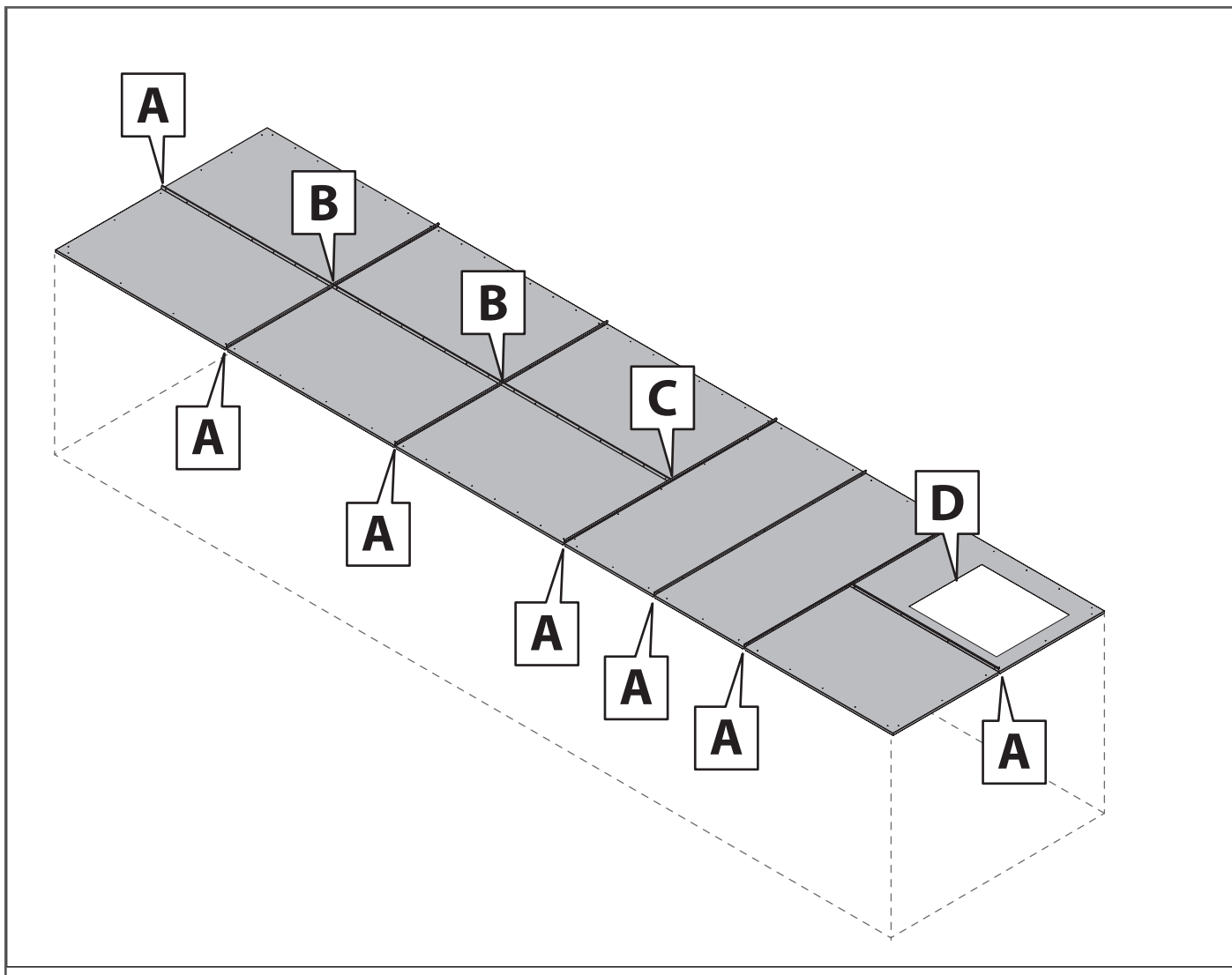

The following figures show the operations to be carried out on the site in order to install the roof properly.

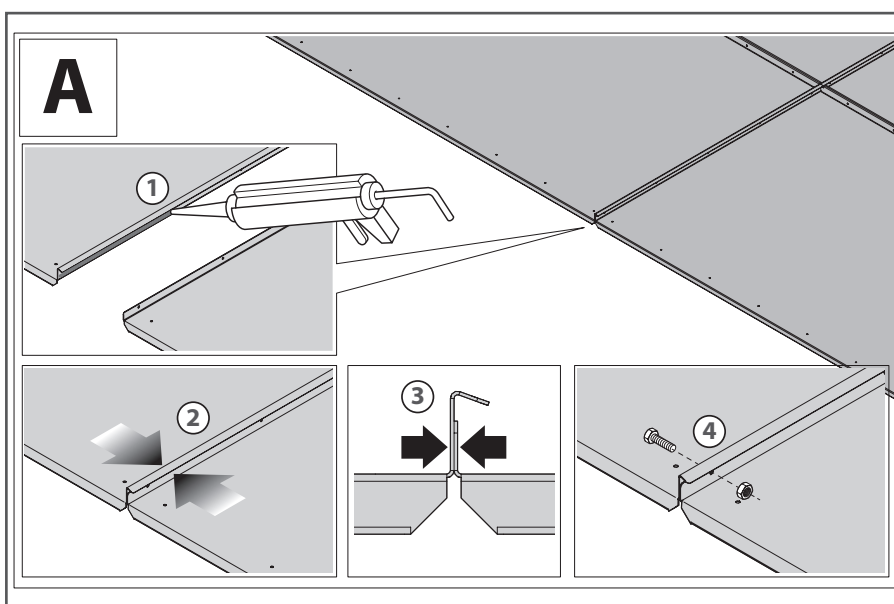

The coupling of the sections will take place as follows:

1. A continuous beading of sealant will be applied over the entire length of the folds of the sheet metal.
2. The sections will be joined.
3. Full contact between the fastened metal sheets will be checked.
4. The sections will be fixed together by means of supplied screws.

The space left free in the intersection between the sheets will be filled with sealant as in figures B and C.

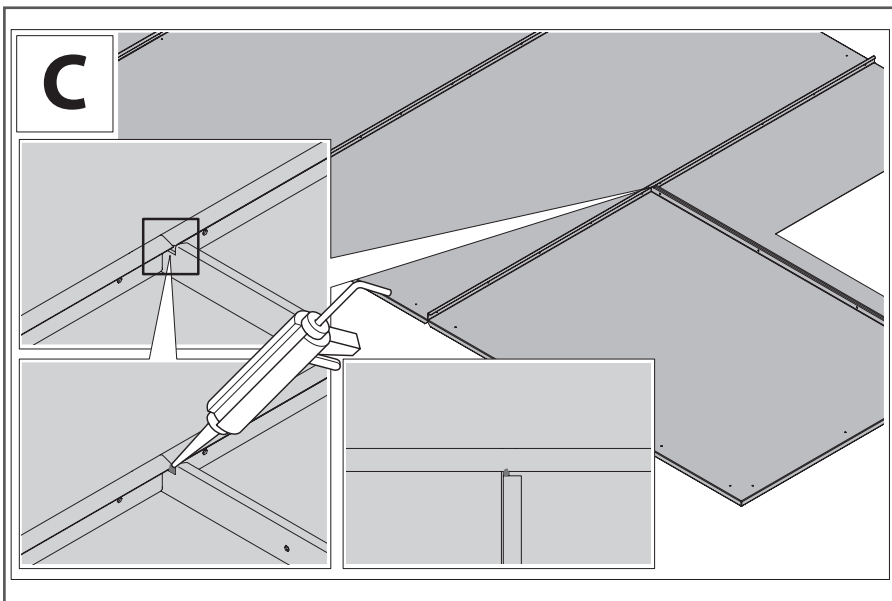
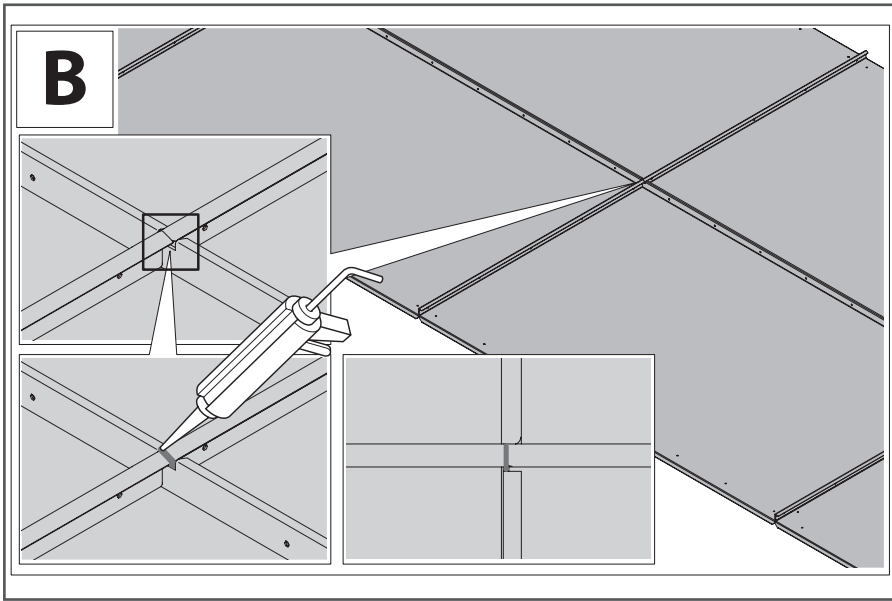

**D** If the roof has a hole, a continuous beading of sealant will be placed between the sheet metal of the roof and the panel on which the roof is fixed.

## Step 5: Make the connections

To operate the machine requires:

- An electrical connection.
- electrical connection of the fans
- A connection to the aeraulic circuit (air ducts).

### Electrical connections



**Always refer to the wiring diagram that is specific to the machine that you bought** (it was shipped with the unit). If it is not on the machine or has been lost, contact the salesperson of reference who will send a copy (specify the machine's serial number).

Before connecting the machine make sure that:

- The voltage and frequency of the power supply correspond to the parameters of the machine.
- The electrical system being connected has sufficient capacity to supply the nominal electric power of the machine to be installed and meets current regulations.



Before connecting the power supply, make sure that the switch on the electrical panel has been turned off



The electrical connection must be:

- Performed by qualified personnel after cutting off the facility's power supply.
- executed in a fixed and permanent way, without intermediate joints, in compliance with the regulations of the country of installation and guaranteeing its correct operation;
- The power supply is sufficient for the machine (see technical specifications).
- Includes a functioning grounded plug; for multiple units it is necessary to combine them all with metal ties.
- Preferably situated in a dedicated room, **locked** and protected from atmospheric agents. If there is also a key switch, the key must be removed when cutting the power supply and returned to its position only after finishing service operations.



During installation and maintenance, make sure that **no other person** besides the one who is working has access to the electrical cabinets or switches.



The actual supply voltage of the user devices **must not deviate more than 10%** from the expected nominal voltage. Higher voltage differences cause damage to users and to the electrical system, malfunctioning of fans, noise. It is therefore essential to check the alignment of the actual voltage values with the nominal values.



The Manufacturer is not responsible for connections made in a manner that does not comply with regulations, with the specifications of this manual, and in the event of tampering with any electrical component of the machine.



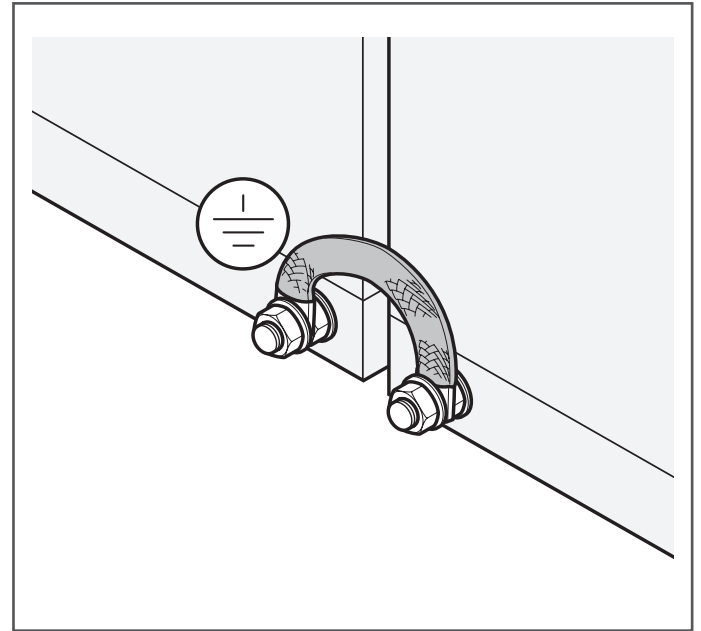
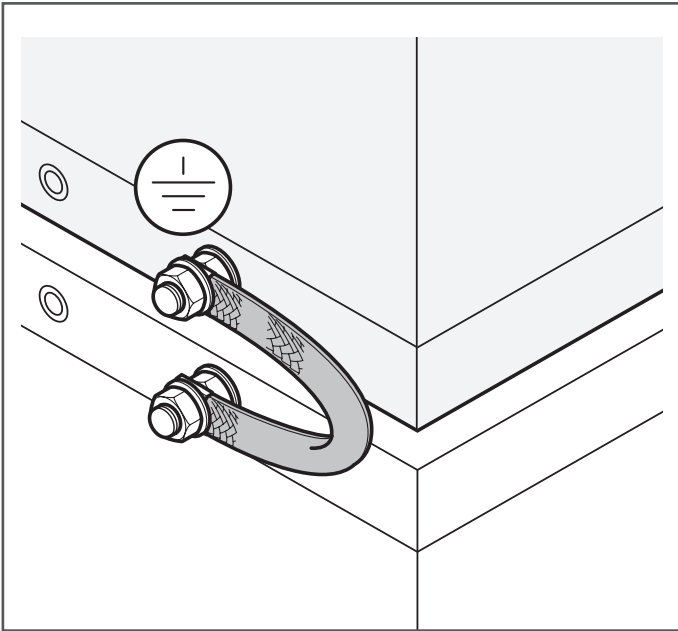

Ground connection of two superimposed modules.

Position of the ground connection on the bases of two adjacent modules.



### **Additional warnings regarding the connection to the power supply:**

It is necessary to install a suitable differential-type protection upstream of the machine's power supply connection points, in order to be able to isolate each of its elements in the event of malfunctions; the choice of the differential protection device must not be in conflict with the provisions of the law, the local regulations, the characteristics of the plant's electrical system and of the machine itself.

They are recommended, where not in contrast with local laws or system characteristics, differential switches with adjustable current and trip time that cannot be affected by high frequency. The cables connecting the various elements of the machine to the power supply must be shielded or must pass through metal ducting, so as to reduce electromagnetic interference.

The shield or metal ducting must be earthed.

Once the system has been set up, the machine can be connected to the electricity supply network. The actual supply voltage of the user devices must not deviate more than 10% from the expected normal voltage. Higher voltage differences cause damage to users and to the electrical system, malfunctioning of fans, noise. It is therefore essential to check the compliance of the actual voltage values with the nominal values. Before connecting the electrical panel, make sure that, during installation and maintenance, no other person besides the one who is working has access to the electrical cabinets or switches.



After connecting, make sure that:

The ground connection is sufficient (using the appropriate tool). An incorrect connection, ineffective and lacking the grounding circuit, is contrary to safety regulations and is a source of danger that can damage the components of the machine.

The connections are correct and the current consumption of the motor is lower than indicated on the nameplate.

It is the responsibility of the machine buyer/user to provide adequate instruction and training to machine operators.

Optional:

In agreed cases, additional training may be provided through the one-on-one instruction of operators by the Manufacturer's technical staff.

## Electrical connection of the fans

### Fans with three-phase asynchronous motors (Double suction and Plug fan)

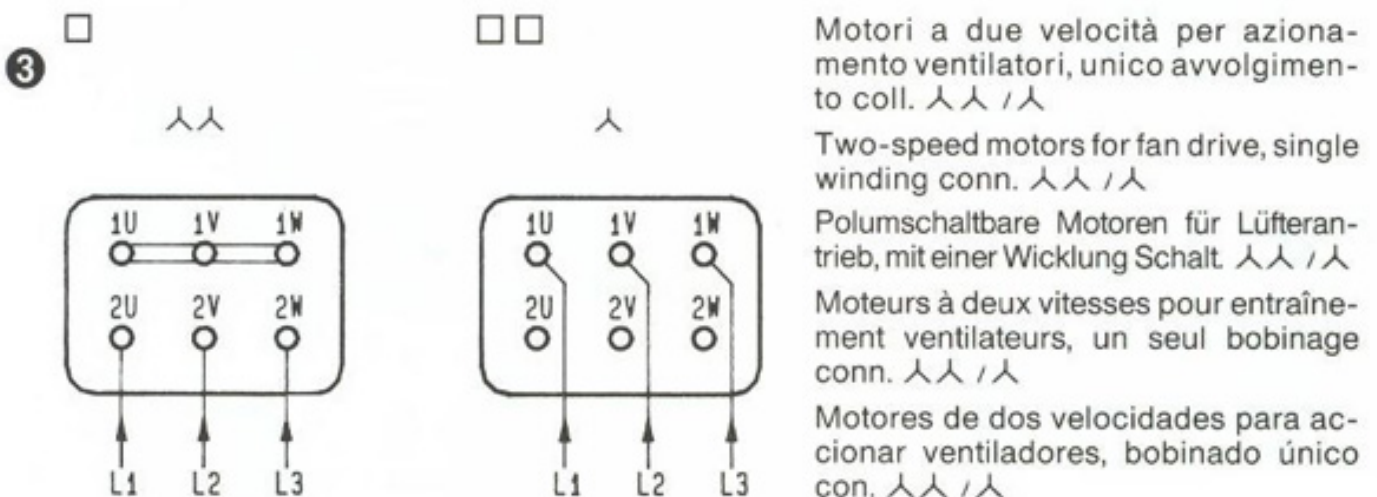
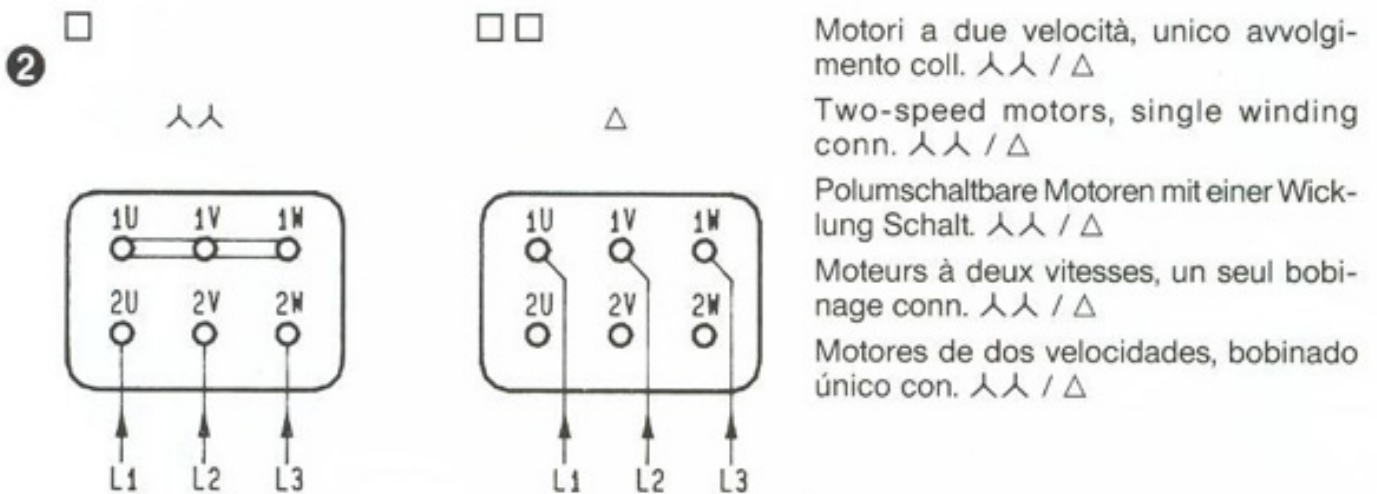
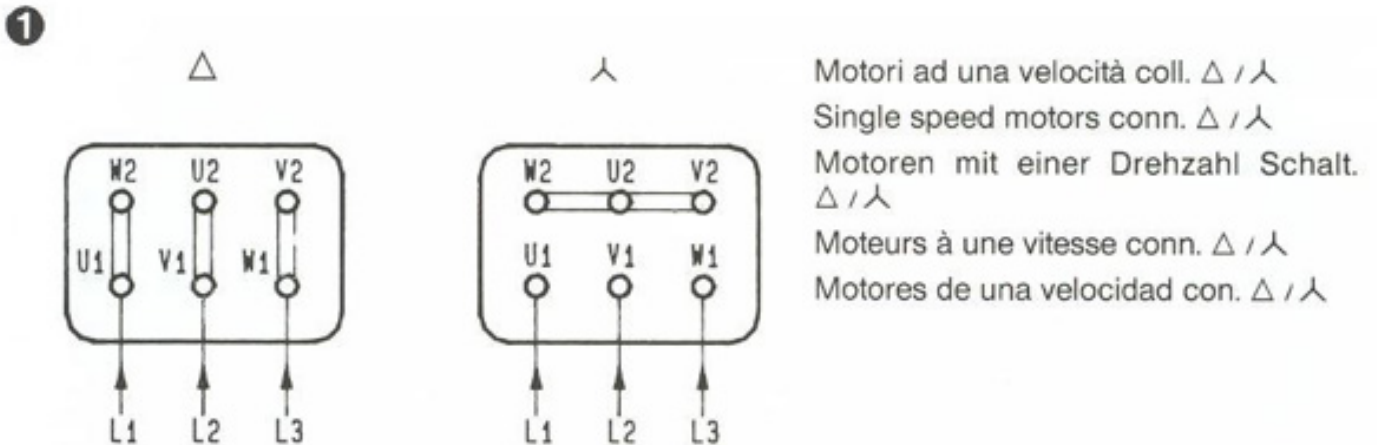

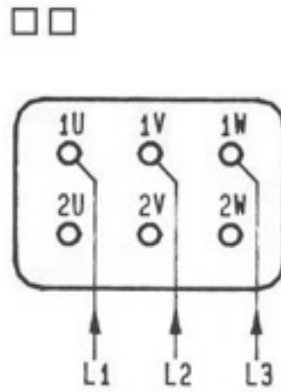
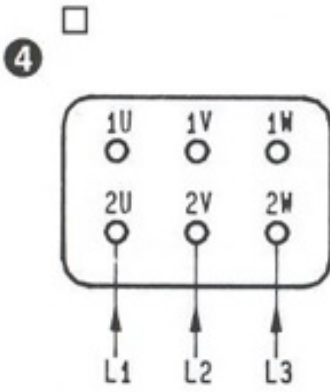

Motori a due velocità, doppio avvolgimento

Two-speed motors, double winding

Polumschaltbare Motoren mit zwei getrennte Wicklungen

Moteurs à deux vitesses, double bobinage

Motores de dos velocidades, bobinado doble

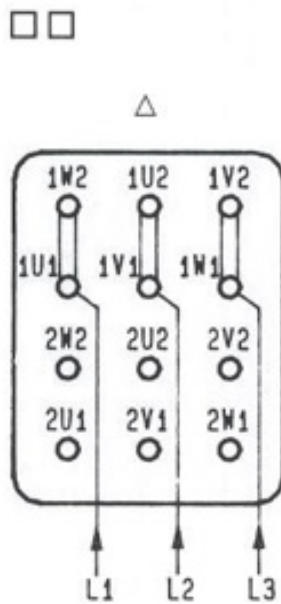
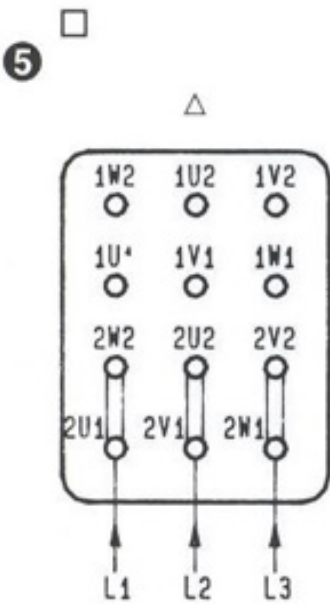

Motori a due velocità doppio avvolgimento doppia tensione coll. △ / 人

Two-speed motors double winding double voltage conn. △ / 人

Polumschaltbare Motoren mit zwei getrennte Wicklungen zwei Spannungen Schalt. △ / 人

Moteurs à deux vitesses double bobinage double tension conn. △ / 人

Motores de dos velocidades bobinado doble tensión doble con. △ / 人

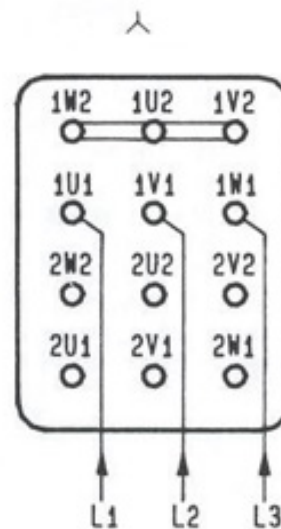
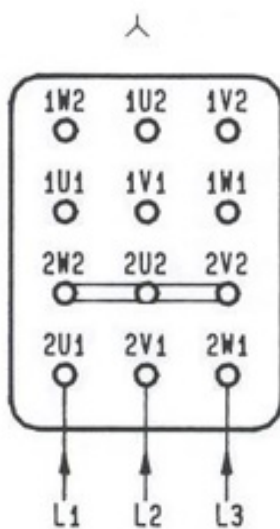

alta velocità  
high speed  
höhere Drehzahl  
grande vitesse  
velocidad alta

bassa velocità  
low speed  
niedrigere Drehzahl  
petite vitesse  
velocidad baja

## EC fans connection

EBM PAPST fans - Connection terminal blocks (check the type of terminal block installed on the fan)



Type 1

Type 2

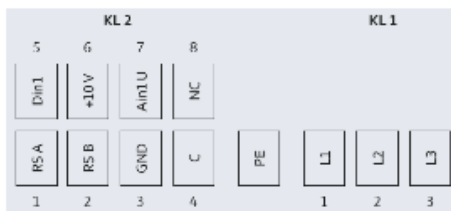

Type 3

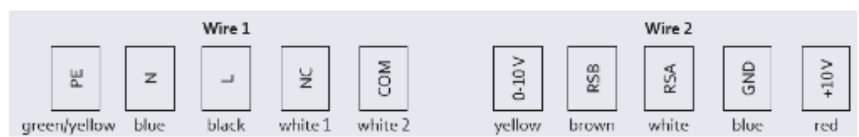

Type 4 with connection cables

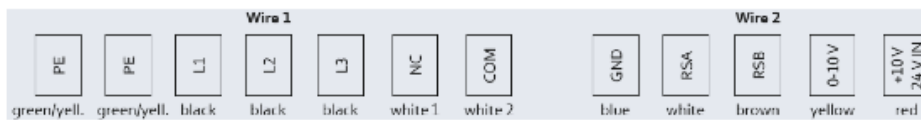

Type 5 with connection cables



Type 6



Type 7

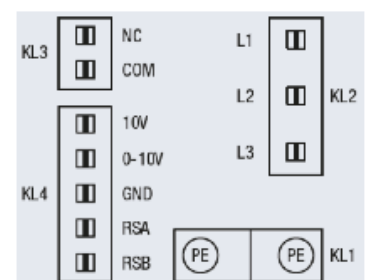

Type 8

### Key:

Power supply: L/L1 – N = 230/1/50-60 Hz ÷ L1 – L2 - L3 = 400/3/50-60 Hz ÷ PE = Ground

Terminals common to all fans

**GND:** reference for analogue signal and Modbus BUS

**RSA-RSB:** Modbus line

**C/COM-NC:** Fan alarm signal digital output (open clean contact with fan not powered and in case of failure, closed contact with fan in normal operation).

**Type 1** terminal block

**IO1:** Fan operation enabling. Closed contact between IO1 and GND; the fan stops. Open contact between IO1 and GND; the fan starts

**IO2:** 0-10 V analogue signal input for fan speed modulation

**IO3:** 0-10 V analogue signal output (feedback signal)

**Type 2** terminal block

**Din1:** Fan operation enabling. Closed contact between Din1 and GND; the fan stops. Open contact between Din1 and GND; the fan starts

**NO/COM:** Fan alarm signal digital output (closed clean contact when the fan is not powered and in case of failure, open contact with the fan in normal operation).

**Ain2U:** 0-10 V analogue voltage signal input for fan speed modulation

**Ain2I:** 4-20 mA analogue current signal input for fan speed modulation

**Aout:** 0-10 V analogue output (feedback signal)

**+10V:** 10 V direct current output (possibility of fan modulation with external 10 kOhm potentiometer between terminals +10 V/GND/Ain2U (see wiring diagram for potentiometer connection)

**+20 V:** 20 V direct current output for connection of external sensors (max current 50 mA)

**Type 3** terminal block

**Din1:** Fan operation enabling. Closed contact between Din1 and GND; the fan stops. Open contact between Din1 and GND; the fan starts

**Ain1U:** 0-10 V analogue voltage signal input for fan speed modulation

**+10V:** 10 V direct current output (possibility of fan modulation with external 10 kOhm potentiometer between terminals +10 V/GND/Ain2U (see wiring diagram for potentiometer connection)

**Type 4** terminal block

**0-10 V:** 0-10 V analogue voltage signal input for fan speed modulation

**+10V:** 10 V direct current output (possibility of fan modulation with external 10 kOhm potentiometer between terminals +10 V/GND/Ain2U (see wiring diagram for potentiometer connection)

**Type 5** terminal block

**0-10 V:** 0-10 V analogue voltage signal input for fan speed modulation

**+10V:** 10 V direct current output (possibility of fan modulation with external 10 kOhm potentiometer between terminals +10 V/GND/Ain2U (see wiring diagram for potentiometer connection)

**Type 6** terminal block like type 2 terminal block

**Type 7** terminal block like type 2 terminal block (fan supply 230/1/50-60 Hz)

**Type 8** terminal block

**0-10 V:** 0-10 V analogue voltage signal input for fan speed modulation

**+10V:** 10 V direct current output (possibility of fan modulation with external 10 kOhm potentiometer between terminals +10 V/GND/Ain2U (see wiring diagram for potentiometer connection).

**Ziehl Abegg fans - Connection terminal blocks (check the type of terminal block installed on the fan)**

1360 - 404 (EC055 / EC072)

1360 - 384 (EC090 IP54)

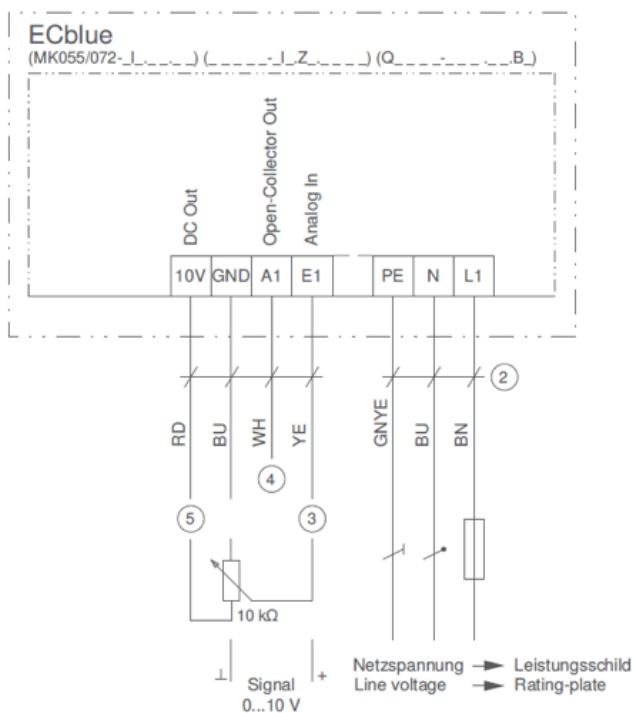

Type 1

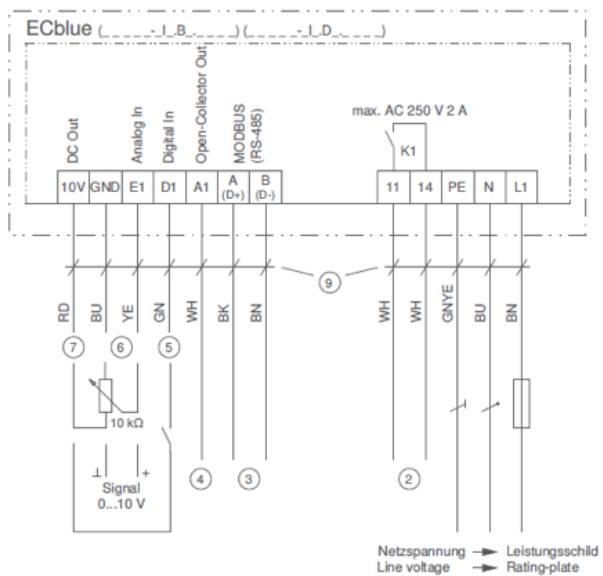

Type 2

1360 - 403 (EC116 / EC152)

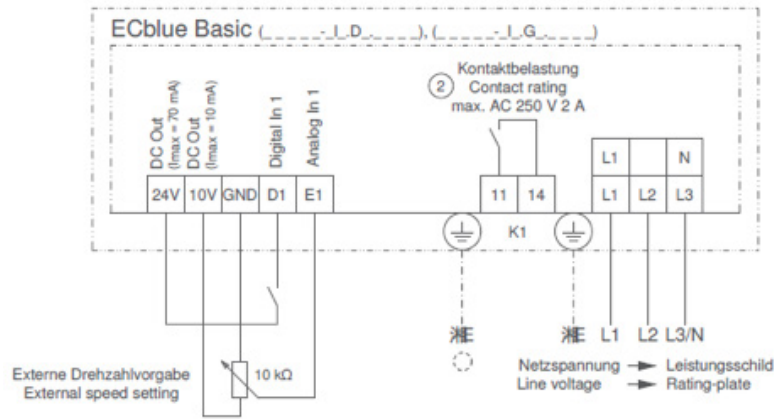

Type 3

AP00001C (EC116 / EC152 2nd generation ECblue)

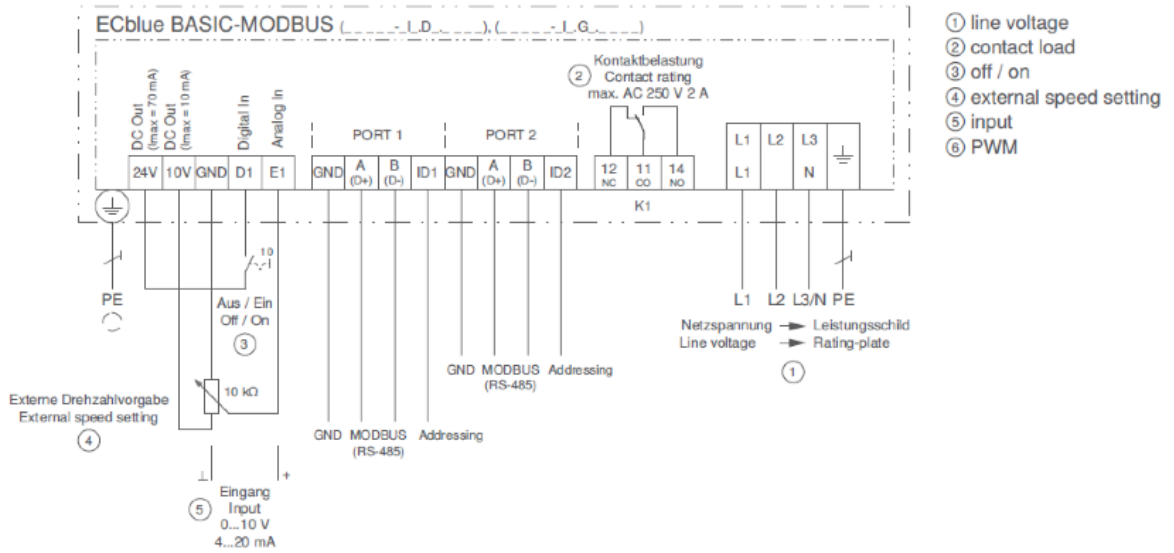

Type 4

AP00001A (EC116 / EC152 2nd generation ECblue)

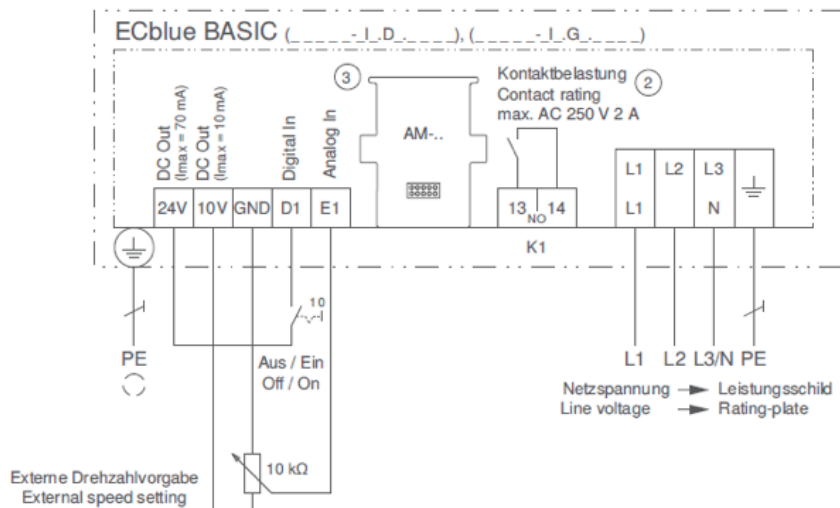

Type 5



**Key:**

Power supply: L1 – N = 230/1/50-60 Hz ÷ L1 – L2 - L3 = 400/3/50-60 Hz ÷ PE = Ground

Terminals common to all fans

**GND:** reference for analogue signal 0-10 V

**Type 1** terminal block

**10V:** 10 V direct current output (possibility of fan modulation with external 10 kOhm potentiometer between terminals 10 V/GND/E1 (max current 10 mA)

**E1:** 0-10 V analogue signal input for fan speed modulation

**A1:** Tacho output (max current 10 mA)

**Type 2** terminal block

**10V:** 10 V direct current output (possibility of fan modulation with external 10 kOhm potentiometer between terminals 10 V/GND/E1 (max current 10 mA)

**E1:** 0-10 V analogue signal input for fan speed modulation

**D1:** Fan operation enabling. Closed contact between D1 and 10 V; the fan starts. Open contact between D1 and 10 V; the fan stops

**A1:** Tacho output (max current 10 mA)

**A-D+/B-D-:** Modbus connection

**11/14:** Fan alarm signal digital output (open clean contact with fan not powered and in case of failure, closed contact with fan in normal operation).

**ID1-ID2:** Modbus line fan automatic addressing (ID1 = input; ID2 = output)

**Type 3** terminal block

**24V:** 24 V direct current output, for start enabling

**D1:** Fan operation enabling. Closed contact between D1 and 24V; the fan starts. Open contact between D1 and 24V; the fan stops

**10V:** 10 V direct current output (possibility of fan modulation with external 10 kOhm potentiometer between terminals 10 V/GND/E1 (max current 10 mA)

**E1:** 0-10 V analogue signal input for fan speed modulation

**11/14:** Fan alarm signal digital output (open clean contact with fan not powered and in case of failure, closed contact with fan in normal operation).

#### **Type 4** terminal block

**24V:** 24 V direct current output, for start enabling

**D1:** Fan operation enabling. Closed contact between D1 and 24V; the fan starts. Open contact between D1 and 24V; the fan stops

**10V:** 10 V direct current output (possibility of fan modulation with external 10 kOhm potentiometer between terminals 10 V/GND/E1 (max current 10 mA)

**E1:** 0-10 V analogue signal input for fan speed modulation

**GND/A/B (PORT1):** Modbus line input

**GND/A/B (PORT2):** Modbus line output

**ID1-ID2:** Modbus line fan automatic addressing (ID1 = input; ID2 = output)

**12/11/14:** Digital output with changeover contact for fan alarm signal (11/14 open clean contact with fan not powered and in case of failure, closed contact with fan in normal operation; 11/12 closed clean contact with fan not powered and in case of failure, open contact with fan in normal operation).

#### **Type 5** terminal block

**24V:** 24 V direct current output, for start enabling

**D1:** Fan operation enabling. Closed contact between D1 and 24V; the fan starts. Open contact between D1 and 24V; the fan stops

**10V:** 10 V direct current output (possibility of fan modulation with external 10 kOhm potentiometer between terminals 10 V/GND/E1 (max current 10 mA)

**E1:** 0-10 V analogue signal input for fan speed modulation

**13/14:** fan alarm signal digital output (open clean contact with fan not powered and in case of failure, closed contact with fan in normal operation).

# Danfoss Inverter set up

Parameters
Select 1** Load/Motor
Select 1-0* General setting
Select 1-03 Torque characteristics = [1] variable torque
Select 3.02 = Min low frequency 0 Hz
Select 3.03 = Max high frequency = Working frequency * 1.05 (working frequency indicated in the GA)
Select 4.12 Low limit Hz =25-30
Select 4.14 High Limit = Working frequency * 1.05 (working frequency indicated in the GA)
Select 6.10 Min limit of signal = 0 V
Select 6.11 Max limit of signal = 10 V
Select 6.14 = Min. frequency = 20Hz
Select 6.15= Max frequency = Working frequency * 1.05 (working frequency indicated in the GA)

Wiring for start/stop

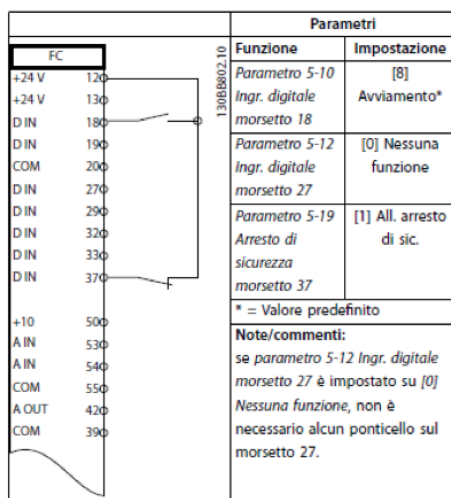

Wiring for open loop speed control

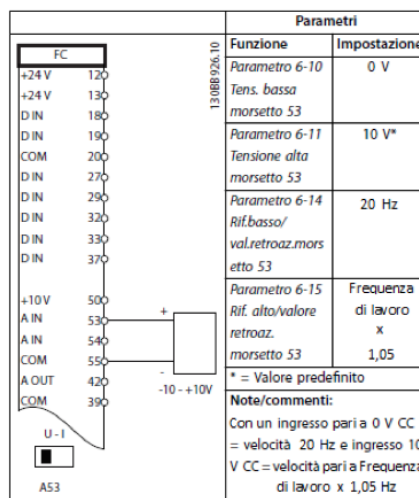

Alarm relay

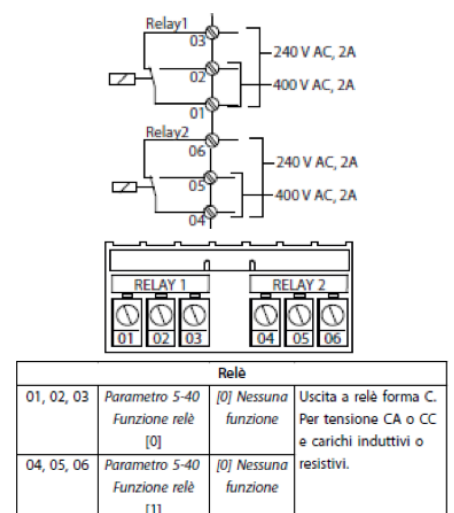

For the complete list of settings, features, alarms, etc. refer to the Danfoss manual.

## Water connections

### Drain and siphon

In correspondence with the humidification sections and the thermal exchange cooling coils, the air handling units are equipped with a threaded drain that **protrudes laterally for about 80 mm**.

In order to allow a regular flow of water, each drain must be fitted with a properly sized SIPHON.

**IMPORTANT**

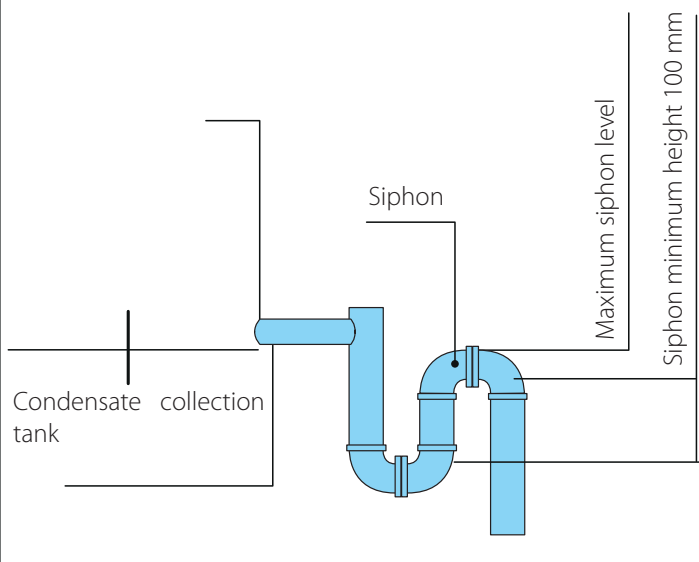

CONDENSATE COLLECTION TANK

With an upper fan head of about 100 mm and a total static pressure exceeding 1000Pa, increase the height of the siphon by 10 mm every 10 mm of head and every 100Pa of total static.

Drain siphon

**Ball siphon** - Installation with positive pressure basin (section downstream of the fan)

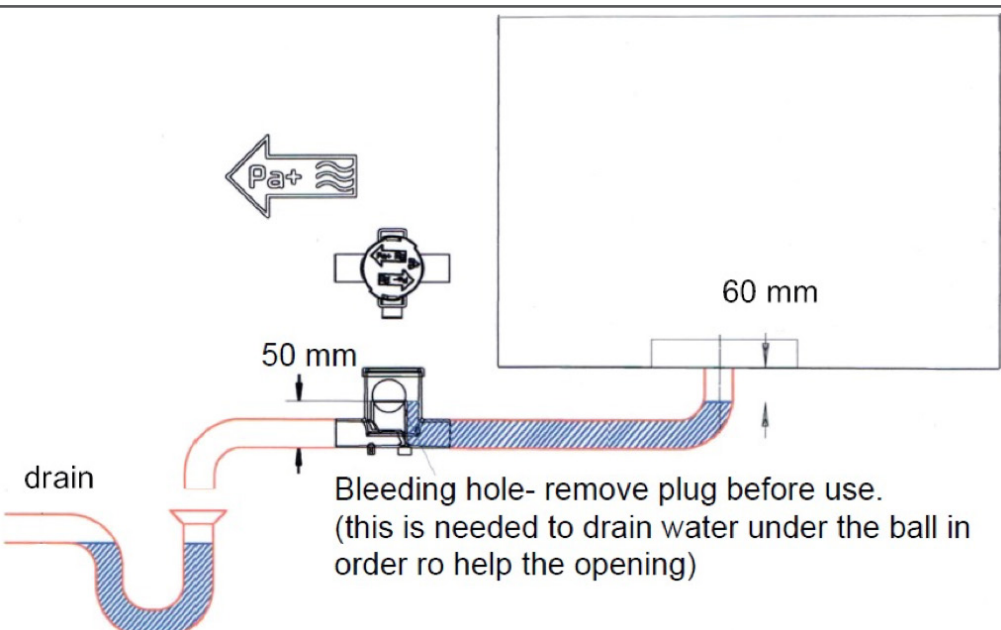

60 mm

50 mm

drain

Bleeding hole- remove plug before use.  
(this is needed to drain water under the ball in order to help the opening)

ball siphon

**Ball siphon** - Installation with negative pressure basin (section upstream of the fan)

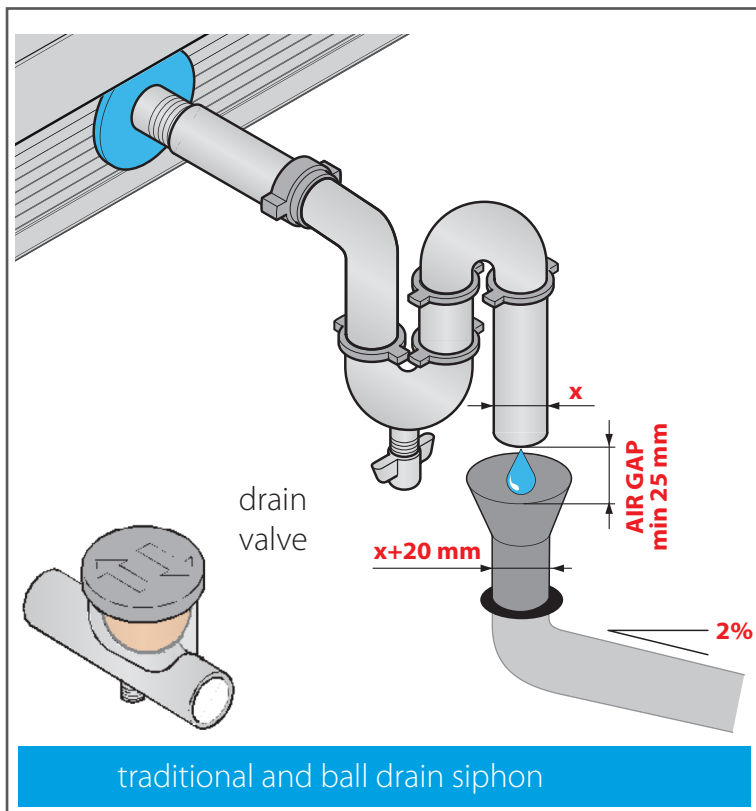
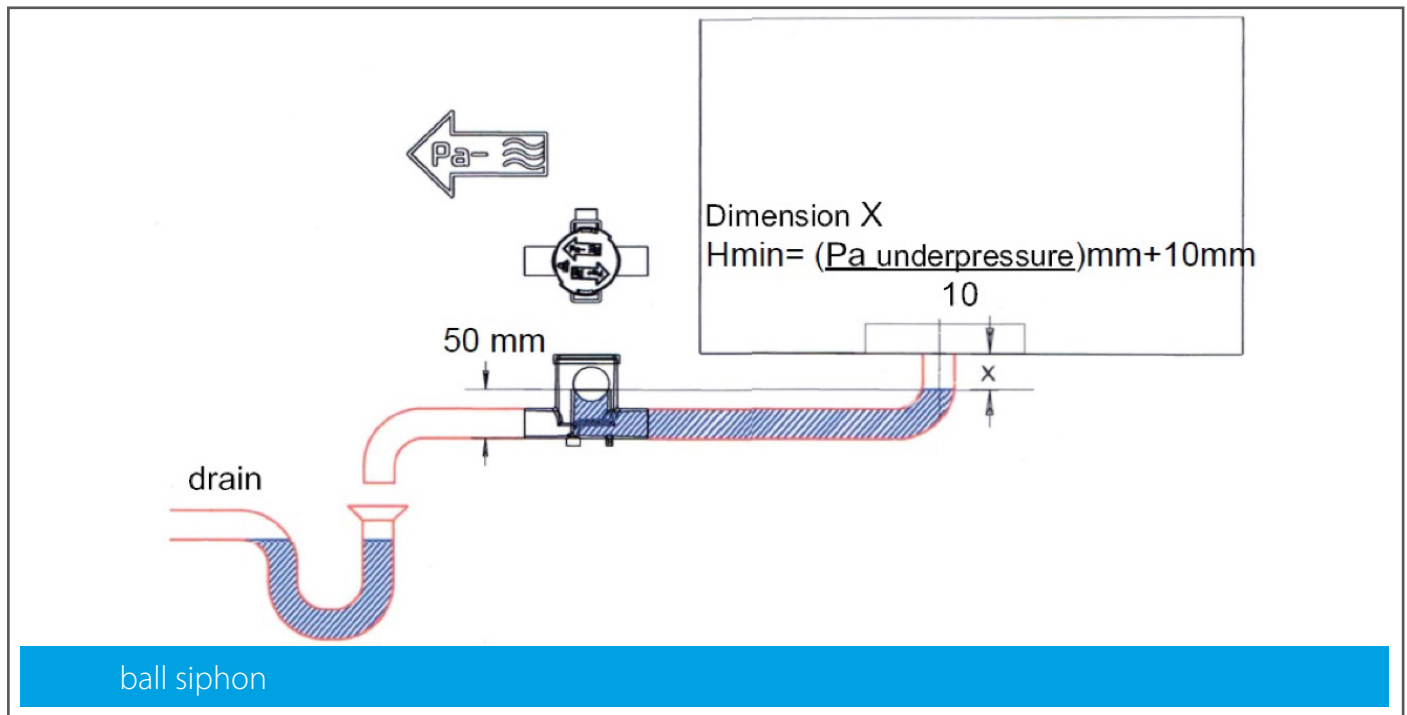

To avoid overflows from the collection tank and consequent flooding of the machine as well as the room in which it is installed, the siphon must have a **purge valve** that allows the removal of impurities deposited on the bottom.

In order not to affect the operation of the drainage system, siphons operating under pressure must NOT be connected to others operating under vacuum.

- The drainage pipe to the sewerage network:
- **Must not be connected directly to the siphon.** This in order to absorb returns of air or slurry and to make the correct outflow of waste water visible.
  - Must have a larger diameter at the machine drain and a minimum inclination of 2% in order to ensure proper operation.

 For fan heads not exceeding 1000 Pa (100 mm of water column),  $H = 100$  mm can be considered; for every 100 Pa (10 mm of water column) of fan pressure in excess of the initial pressure, increase the height "H" by 10 mm. In the case of humidification systems with recirculation pump, to avoid increasing the concentration of salts in the humidification tank, it is important to continuously drain some water into the overflow, appropriately adjusting the valve installed in the by-pass pipe derived from the delivery pipe to the pump. To avoid excessive consumption of water in the humidification tanks it is necessary to adjust the float valve.

 In order not to affect the operation of the drainage system, siphons operating under pressure must NOT be connected to others operating under vacuum.

## Water or coolant gas connections

Connections to water or to a coolant gas are required for the installation of a water or direct expansion coil (optional).

For the **water/gas supply** it is necessary to connect the manifolds to **pipings having a size that is sufficient for the flow rates envisaged**: in order to avoid damage to the heat exchange coil in correspondence with the junction between the steel fluid supply manifold and the copper circuits, it is necessary, when fixing the system pipe, to use a double wrench so as not to overload the coil connections.

In order to ensure optimum heat exchange of the coils it is necessary to:

- WASH them prior to connecting them to the network.
- Completely eliminate the air present in the water circuit using suitable valves.

Apart from the heat transfer fluid used, the thermal exchange with the air occurs in flow, with counter flow injection with respect to the flow of the treated air. Connect the pipes following the indications of the plates placed on the machine's panel.



**Take care that no moisture or dirt enters the heat exchange coil.**

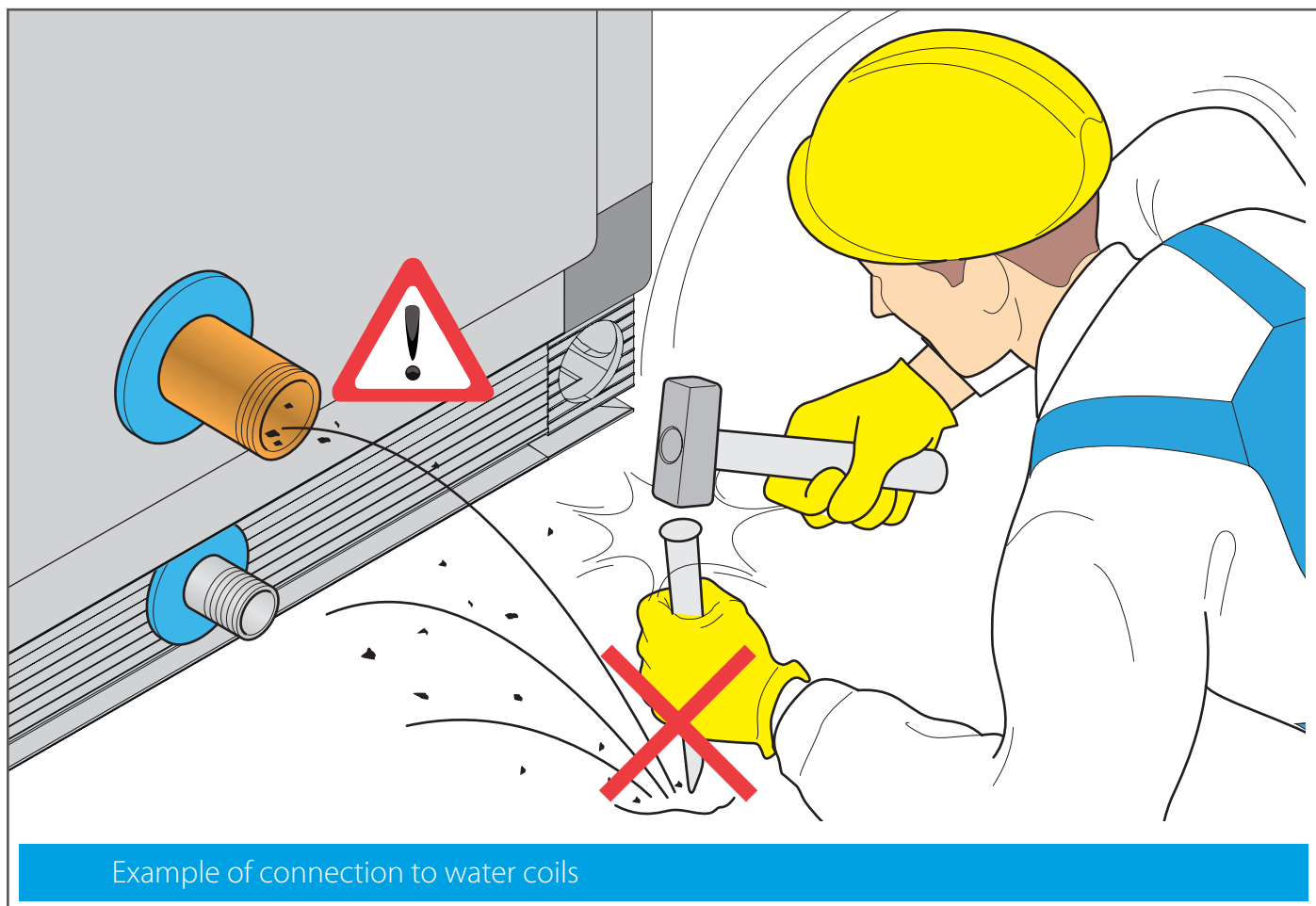

## Water-based heat exchange coils

The heat exchange coils are installed with horizontal pipes.

The circuit pipes must have a size based on the nominal flow rate calculated from the thermal output of the project and indicated in the data sheet of the unit.



Do not use the heat exchange coil connections to support the weight of the piping. It is necessary to prepare appropriate fasteners and brackets (not supplied).



**Shut-off valves** must be included to exclude the heat exchange coil from the water circuit.

In the heating coils, a stopped fan could lead to the overheating of the stagnant air in the machine, with possible consequential damage to the motor, bearings, insulation and parts made of synthetic material. To avoid such eventualities it is advisable to design the system so that a stopped fan will also stop the passage of the heat transfer fluid.

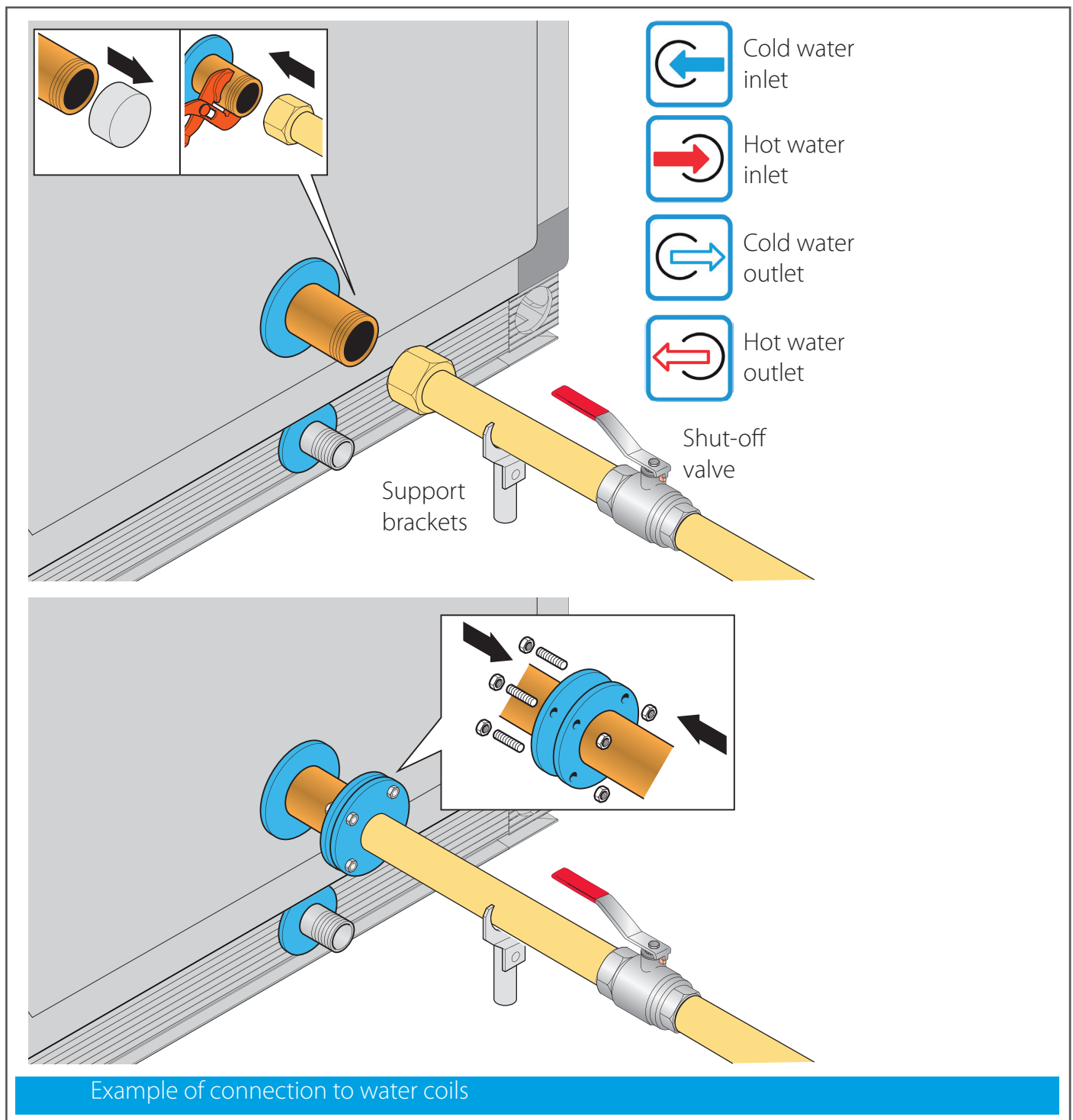

## Acceptability limits of the quality of the water supplying the coils

PH (25°C)	6.8÷8.0	Iron (mg Fe / l)	< 1.0
Electrical conductivity $\mu\text{S}/\text{cm}$ (25°C)	< 800	Sulphide ion (mg S <sup>2-</sup> / l)	None
Chloride ion (mg Cl <sup>-</sup> / l)	< 200	Ammonium ion (mg NH <sub>4</sub> <sup>+</sup> / l)	< 1.0
Sulphate ion (mg SO <sub>4</sub> <sup>2-</sup> / l)	< 200	Silica (mg SiO <sub>2</sub> / l)	< 50
Total hardness (mg CaCO <sub>3</sub> / l)	< 200	Antifreeze	< 60%

Water and steam coil execution **PN16**



## Direct expansion heat exchange coils



The filling by the installer must be performed according to current regulations and by authorised personnel, authorised for the use and handling of refrigerants.

The heat exchange coils are installed with horizontal pipes.



Do not use the heat exchange coil connections to support the weight of the piping. It is necessary to prepare appropriate fasteners and brackets (not supplied).

The system piping must be connected to the heat exchange coil with braze welding, circulating **anhydrous nitrogen** inside the pipes to prevent formation of oxides from forming. The liquid suction pipes must be the appropriate size for the expected capacity and to ensure the circulation of the oil present in the refrigerant circuit even when the heat exchange coil operates at minimum load.



Use of wet patches to protect the plastic against the heat of the flame.

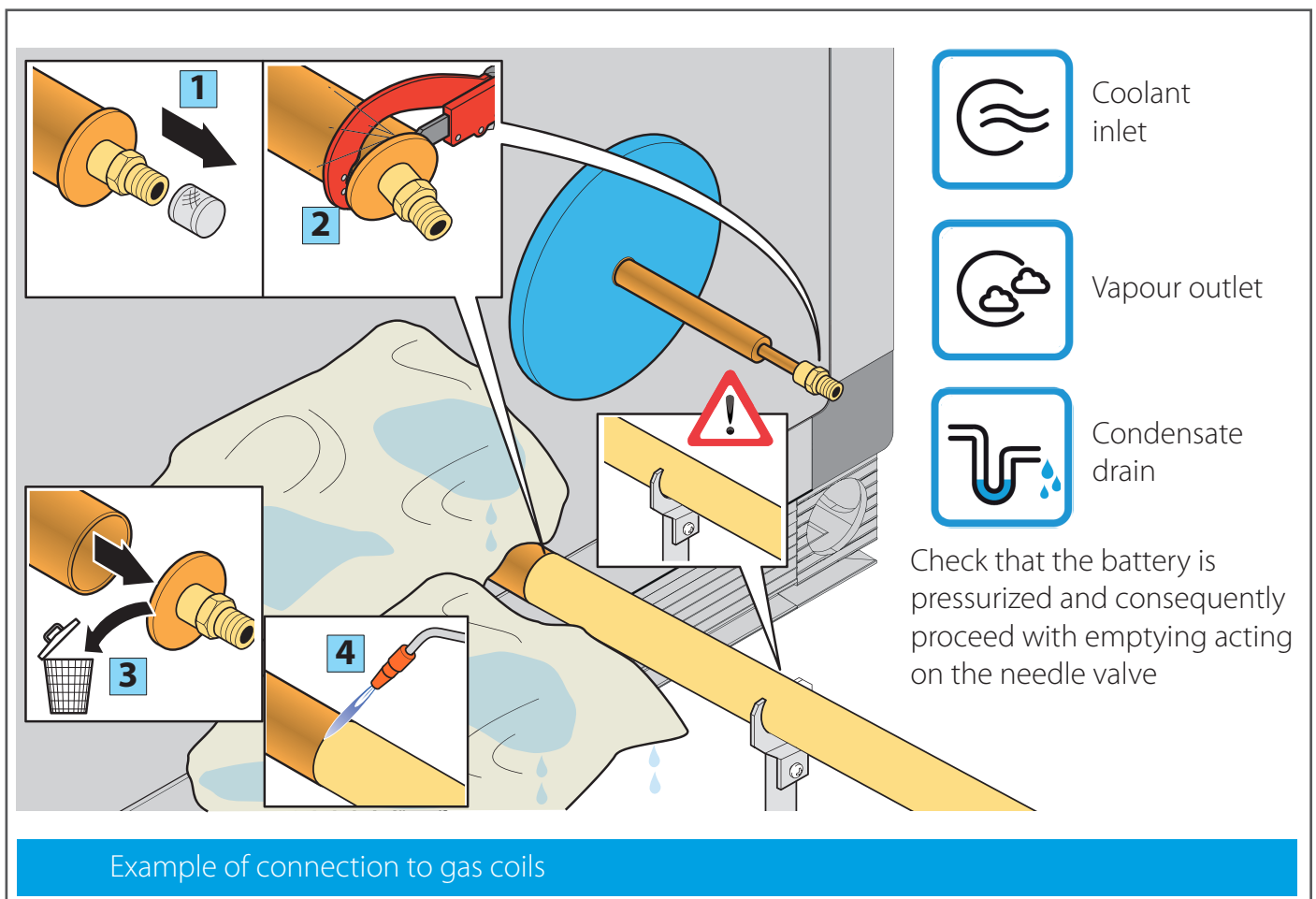

The diameter of the pipes of the external refrigeration circuit must be sized according to the prescriptions of the manufacturer of the outdoor units connected to the coils.

## Heat exchange coil connections

Note:

After the connection, make sure that there is no air in the system, using the special valves positioned on the water circuit. Shut-off valves must be provided to exclude the battery from the hydraulic circuit. All batteries must be complete with a special valve for complete drainage of the battery itself and for air vent.

### Water coils

The piping of the water coil circuit must be sized calculating the water flow rate necessary to obtain the design heat output.

### Steam coils

The piping of the circuit must be sized calculating the steam flow rate necessary to obtain the project heat output.

To avoid damage to the battery, the accessories (control valve, condensate drain, shut-off valves) should be correctly sized for the actual pressures and flow rates. In addition, the supply steam must be dry saturated to avoid condensate to be dragged and prevent water hammers.

To avoid the formation of vacuum inside the battery, provide a vacuum breaker valve in the steam inlet area. To avoid overheating of the machine parts, it is essential that the steam flow is intercepted when the fan has stopped. Post-ventilation must therefore be guaranteed after the unit has stopped.

### Direct expansion coils

Prepare the connection to the coil as follows:

- Cut the manifold.
- Remove the protective caps from the distributor.

The system pipes must be connected to the coil connections by brazing. It will be necessary to provide thermostatic expansion valves, shut-off valves, filter driers, sight glasses. The refrigerant suction pipes must be sized for the expected capacity and in such a way as to ensure the circulation of oil even when the coil operates at minimum load. In order to prevent the oil in the refrigerant from remaining blocked in the coil, it is necessary to maintain gaseous refrigerant speeds higher than 6m/sec. in the vertical sections and at least 2.5 m/sec. in the horizontal sections. These values are indicative. During partial load operation, the speeds will be reduced, therefore it is essential to provide adequate oil siphons and a tilted suction pipe in the circuit. To connect electrical control boards and build refrigeration lines to Daikin EV valves, refer to the supplied manual (Option kit for combination of Daikin condensing unit with field-supplied air handling units)

### Electric heaters

In electric heaters there is a safety limit thermostat, which is used to control the disconnection of the power circuit. Specifically, this thermostat must communicate with the control unit of the electrical panel to turn the electric heater on or off, in order to reach the required temperature and prevent the operation of the same in the absence of ventilation, interlocking the operation of the heater with that of the fan.

## Electric heater connections

For a correct and safe use of the electric heaters we recommend you make the connections with reference to the following example wiring diagram.

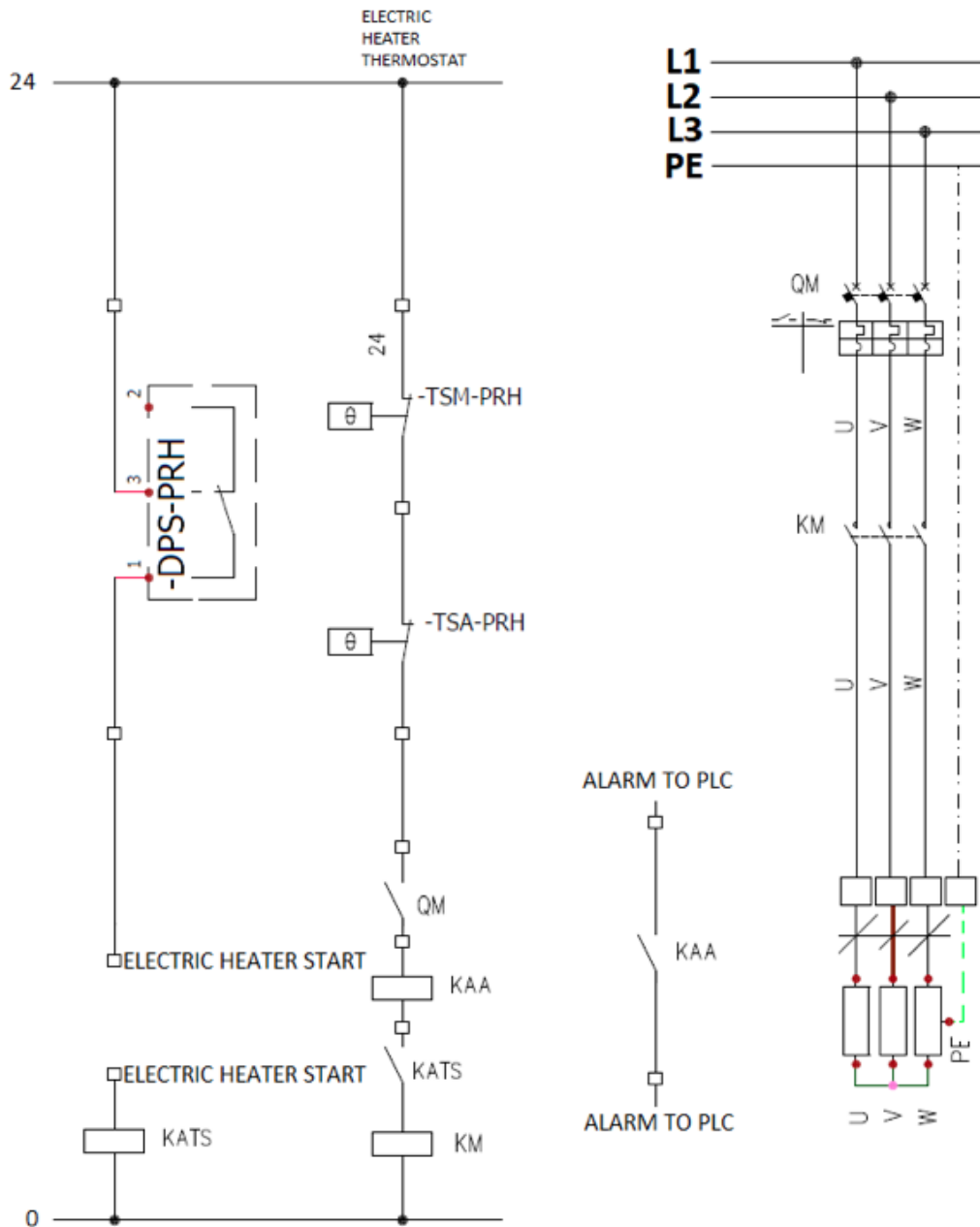

### Key:

DPS-PRH = Flow presence pressure switch (connect + in the fan chamber and - at the suction, or + at the suction and - to the nozzle needle (fan inlet with EC plug fan type or standard with AC motor).

KATS = relay for activating electric heater power contactor

ELECTRIC HEATER START = Heater step (ON) activation signal from PLC

KAA = electric heater overtemperature/thermal trip (QM) alarm relay

TSM-PRH = Safety limit thermostat with manual reset (fixed setting)

TSA-PRH = Thermostat with automatic reset (settable calibration).



**N.B.:** Set a post-ventilation of at least 5 minutes at the unit's project design air flow, after the electric heater is turned off.



During the installation of the electric heaters, check the correct connection of the safety limit thermostat, which cuts power to the heater if the unit is stopped.

### Humidifier connections

In the case of humidification sections with evaporating pack it is necessary to connect this section to the water mains, adopting the appropriate accessories (excluded from the supply of the machine) for correct operation, such as: valves, filters and pressure gauges. In the case of disposable humidification, in addition to the components indicated above, it is also necessary to insert a manual calibration valve, in order to ensure the correct water flow rate. This piping with its accessories must be made in such a way as not to create obstacles to the normal maintenance activities of the section itself, such as cleaning the nozzles or replacing the evaporating pack. For the correct operation of the units it is important that both the drain and the overflow (the sections are equipped with) are not connected directly to the drain pipe that leads to the sewer system.

feed water characteristics for immersed-electrodes-humidifiers	unit of measure	normal waters		waters with low salt content	
		min.	max.	min.	max.
Hydrogen ion activity (pH)		7	8.5	7	8.5
Specific conductivity at 20°C ( $\sigma_R$ , 20°C)	$\mu\text{S}/\text{cm}$	300	1250	75	350
Total dissolved solids (CR)	mg/l	(1)	(1)	(1)	(1)
Fixed residue at 180°C ( $R_{180}$ )	mg/l	(1)	(1)	(1)	(1)
Total hardness (TH)	mg/l $\text{CaCO}_3$	100 <sup>(2)</sup>	400	50 <sup>(2)</sup>	150
Temporary hardness	mg/l $\text{CaCO}_3$	60 <sup>(3)</sup>	300	30 <sup>(3)</sup>	100
Iron + Manganese	mg/l Fe+Mn	=	0.2	=	0.2
Chlorides	ppm Cl	=	30	=	20
Silica	mg/l $\text{SiO}_2$	=	20	=	20
Residual chlorine	mg/l $\text{Cl}^-$	=	0.2	=	0.2
Calcium sulphate	mg/l $\text{CaSO}_4$	=	100	=	60
Metallic impurities	mg/l	0	0	0	0
Solvents, thinners, detergents, lubricants	mg/l	0	0	0	0

### Aeraulic connections

If provided, the air ducts must be connected directly to the machine, taking care to insert a suitable anti-vibration system between the machine itself and the duct: when assembly is complete they must not be taut, in order to avoid damage and the transmission of vibrations.

For the correct operation of the unit, the ducts must be sized according to the system and the aeraulic characteristics of the fan. To ensure the seal of the connections and the integrity of the unit, it is essential that the air ducts must be supported by special brackets that do not weigh directly on the unit.

Air conduits are not supplied with the unit. The installer must buy and install them separately.

If not using anti-vibration joints it is necessary to:

- Clean the joint surfaces between the duct and the unit/coil.
- Apply a gasket to the flange in order to prevent air infiltration.
- Carefully tighten the connecting screws.
- Use silicone on the gasket in order to optimise the seal.

If the connection is made with anti-vibration joints, when assembly is completed they should not be taut, so as to avoid damage and the transmission of vibrations.

For the correct operation of the unit, it is vital that the weight of the ducts does not affect the unit in any way and therefore they must be supported by appropriate brackets and/or structures. In order to have the expected fan performances, the duct section connected to the fan outlet must have the same dimensions as the outlet of the fan.

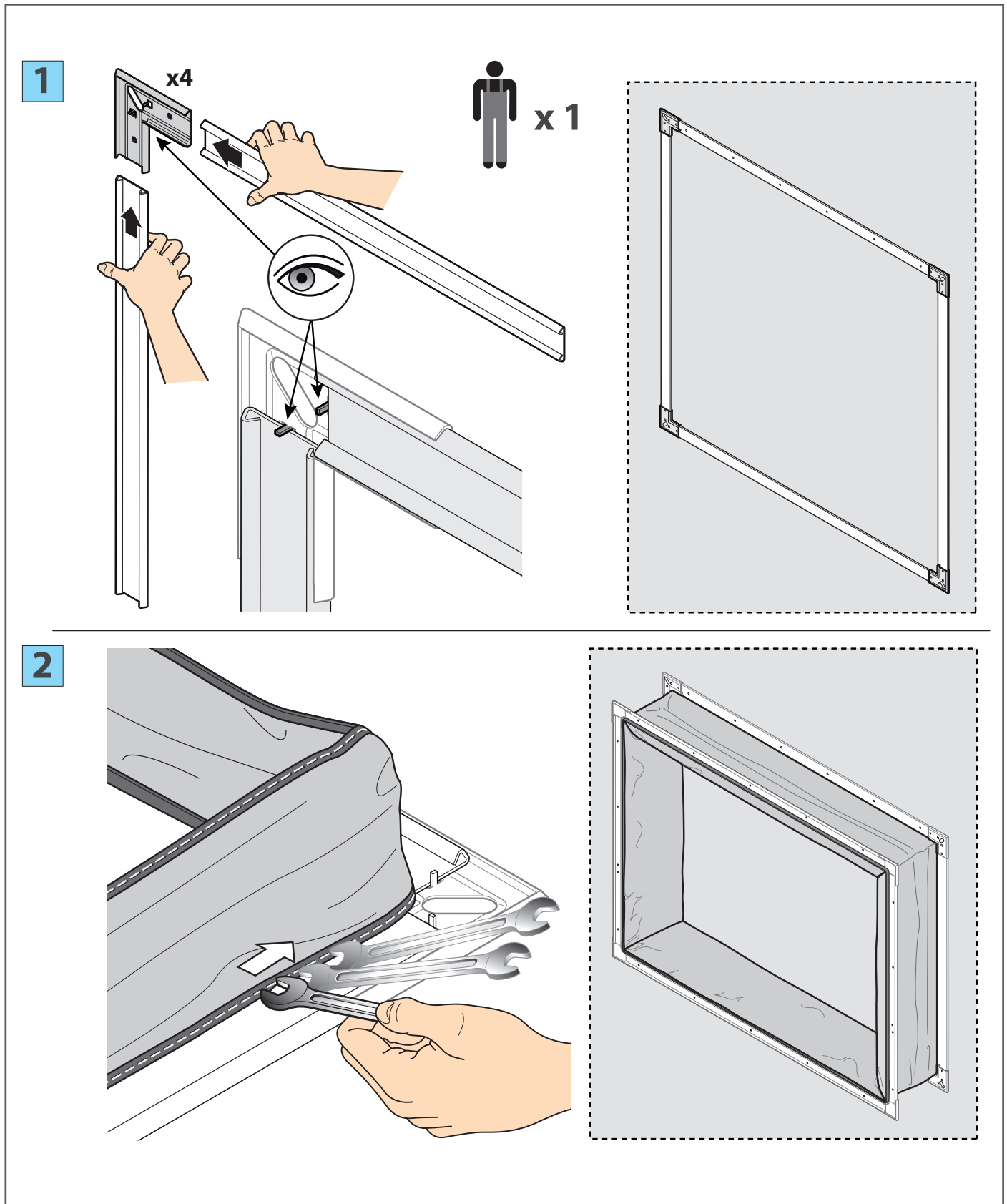

3

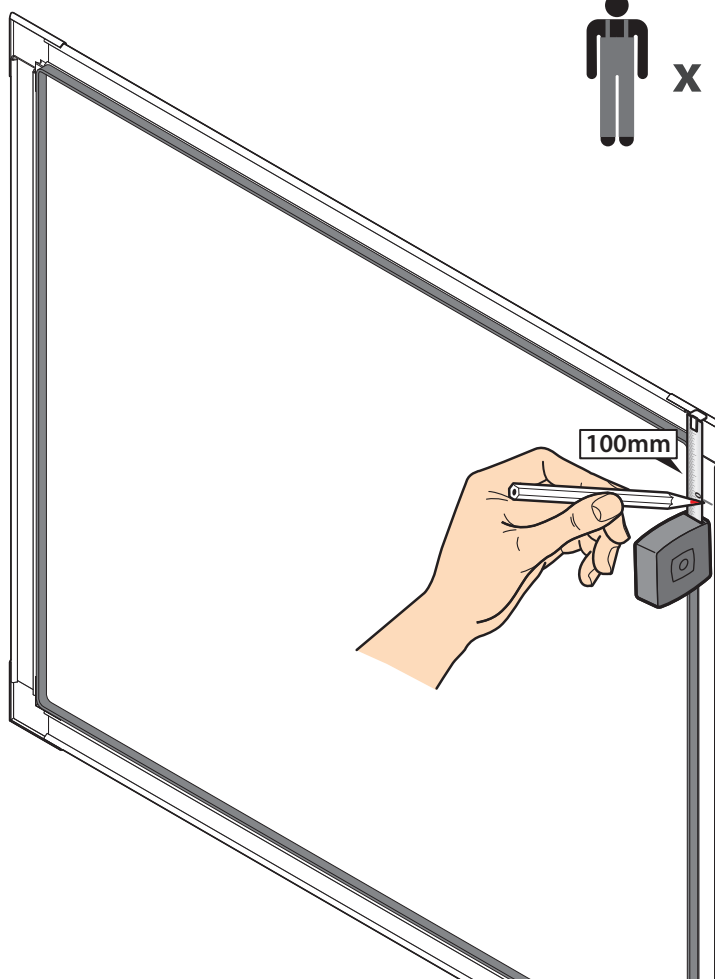
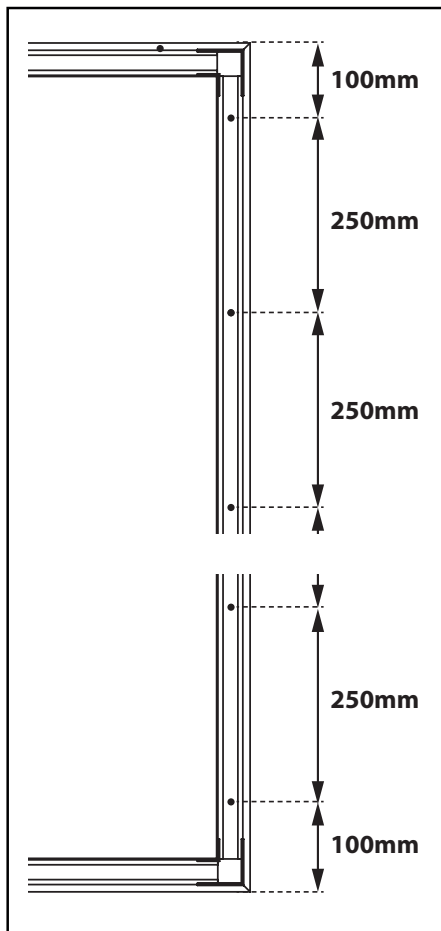

4

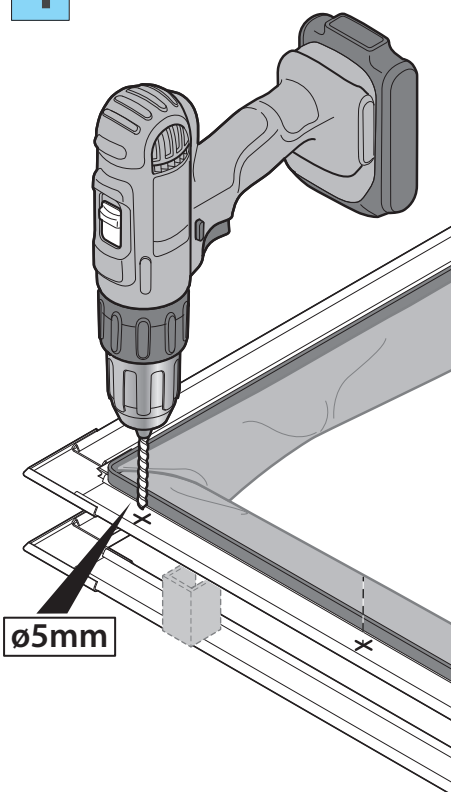

5

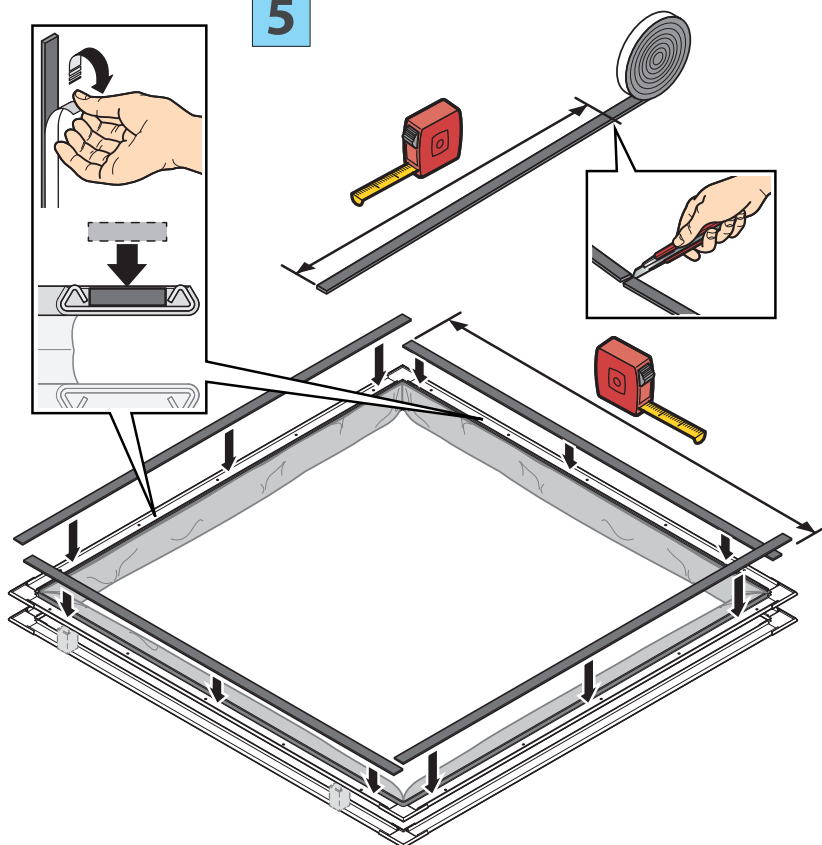

6

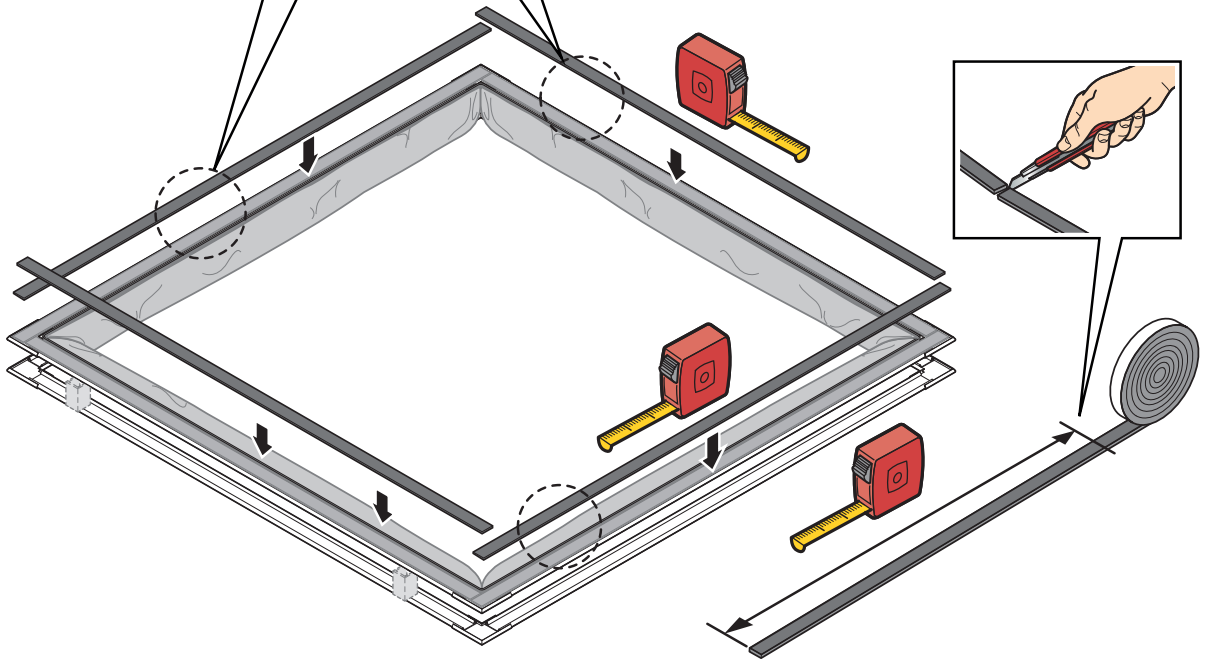
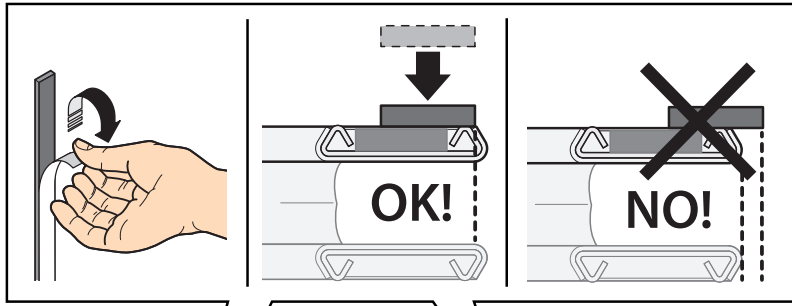

7

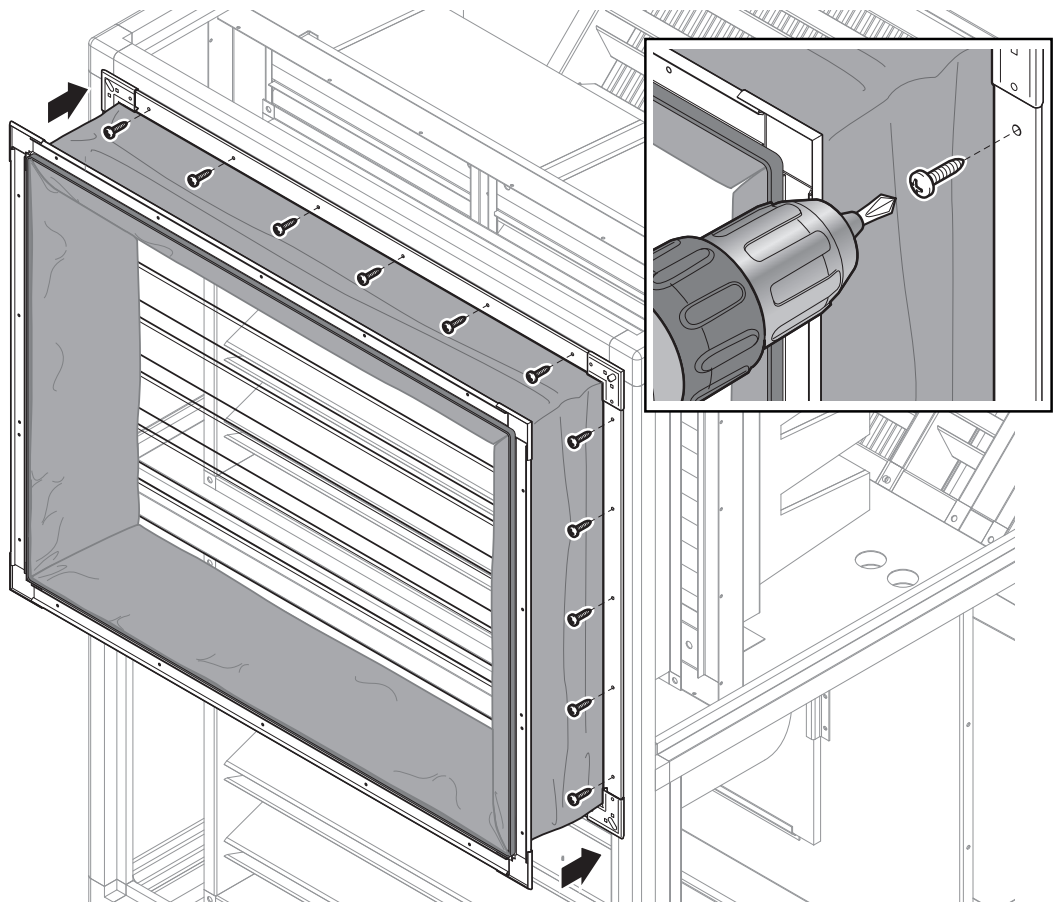

8

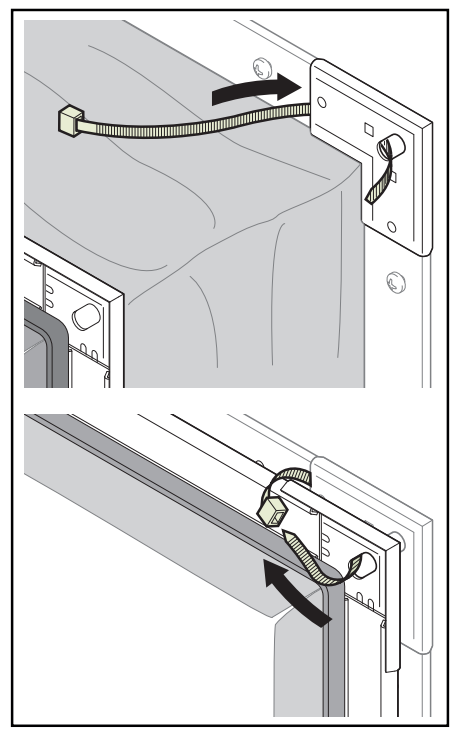
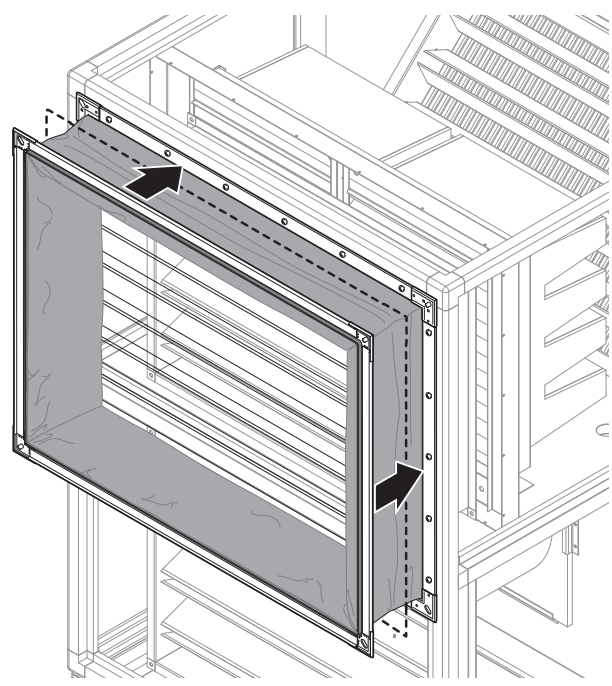
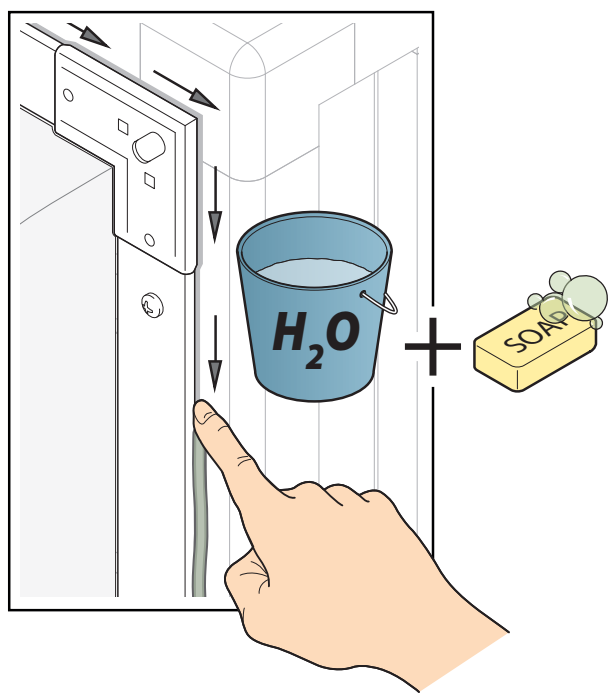
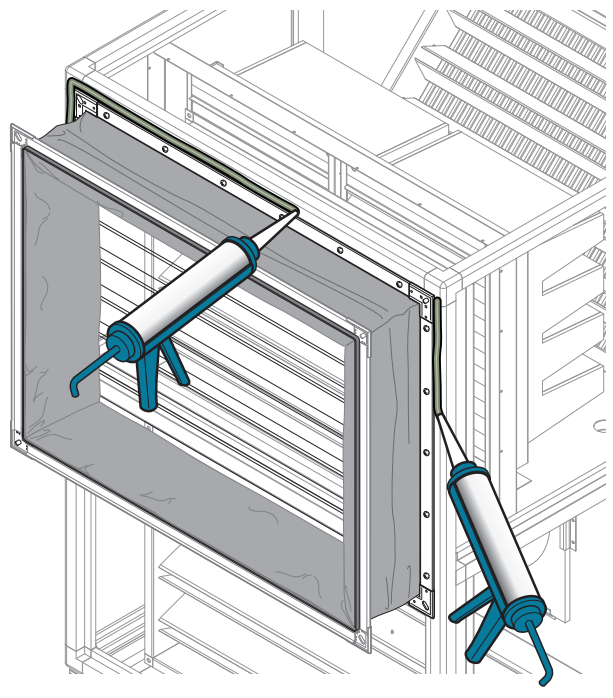



9

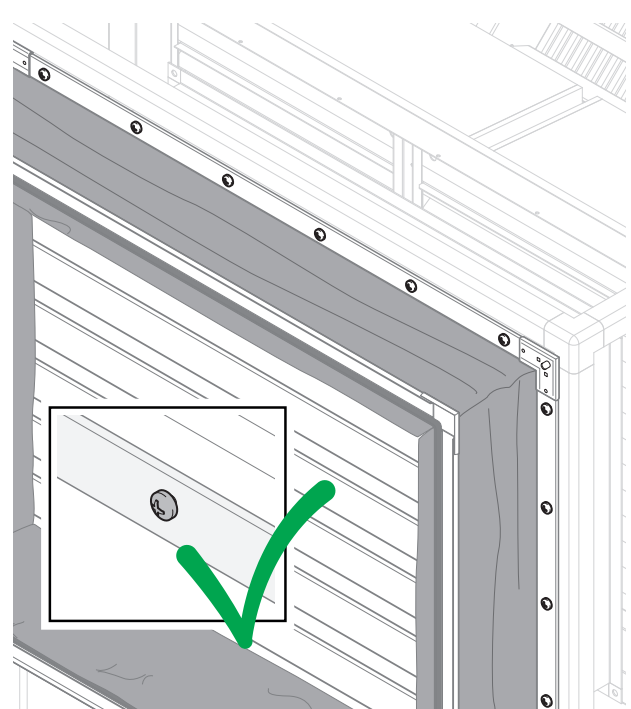
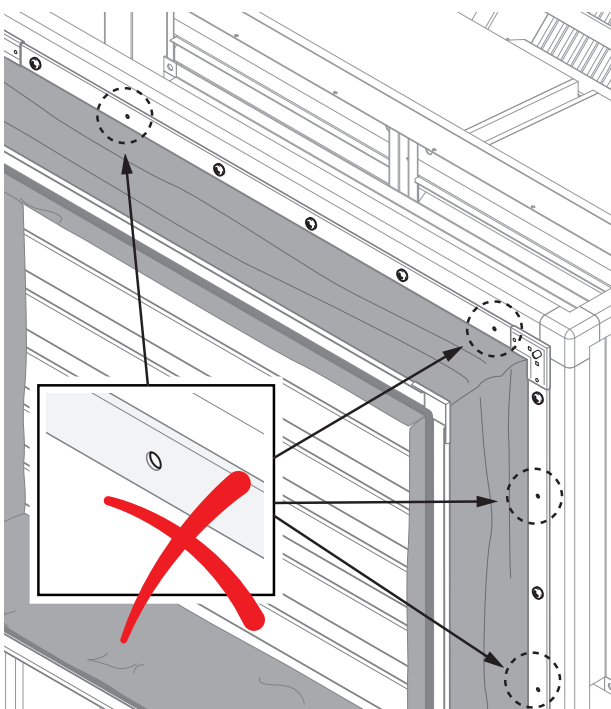
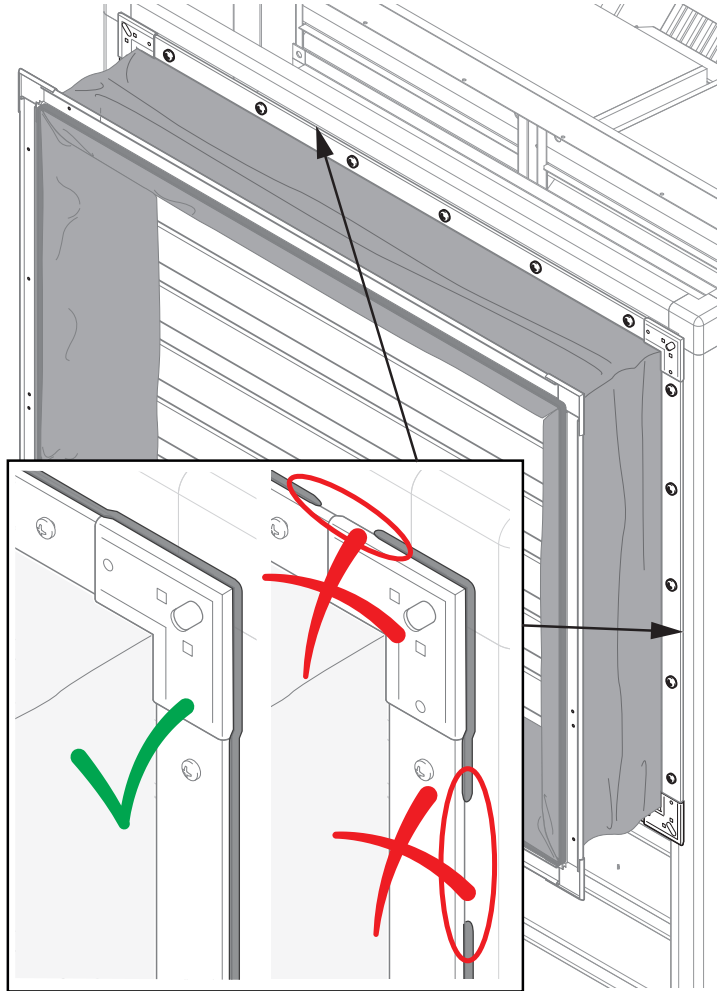
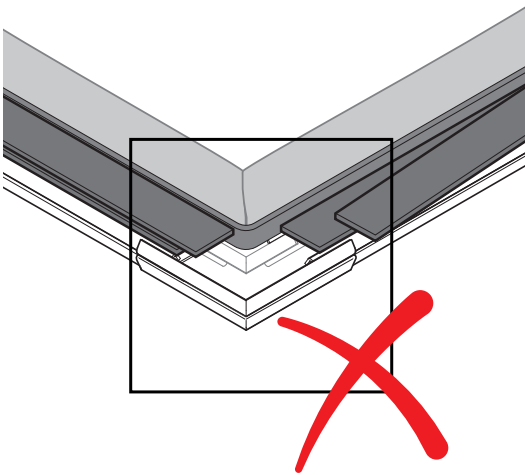
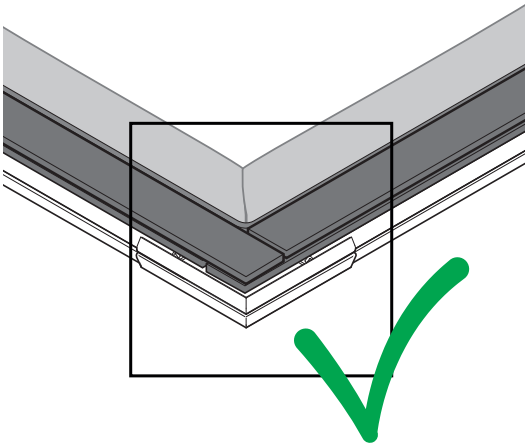

## Step 6: Perform a trial run

To commission the unit it is necessary (tick “√” the operations completed):

	Check the proper connection of the fluid inlet and outlet piping to the thermal (if present) exchange coils (if present).
	Vent the air from the heat exchange coils.
	Check that there is a suitable siphon for all the water being drained.
	Inspect the correct installation and adequate electrical connection of the energy recovery equipment, together with a mechanical and electrical check.
	Insert an anti-vibration coupling between the unit and the ducts.
	Check the tightening of screws and bolts (especially those used to attach motors and fans).
	Check the integrity of the anti-vibration supports and the various accessories.
	Remove extraneous materials (e.g., assembly sheets, tools, clips, etc.) and dirt (footprints, dust, etc.) from inside the sections.

# 7 Control instructions and preparation for the start-up of the unit and its maintenance

## Generalities



The air handling unit must not be started until all the work and checks described in this chapter have been completed!



Before starting work, all power switches must be turned **off and locked out**. Furthermore, all the hydraulic and electrical connections to the respective components of the air handling unit must already be made and the unit must be connected to the duct system.

After carrying out the above mentioned connections, it is necessary **to set up the machine**, according to the following:

- Unlock the shock absorber blocks of the motor-fan units, where present. The most frequent locking systems are tie rods, plates, shims or their combinations, which are used to avoid damage during transport and handling of the machine or its fan sections.
- Check that the coils are connected correctly (input / output).
- Ensure that all coils are vented.
- Recovery systems with twin coils (run-around-coil)

ethylene glycol % v/v	Freezing temperature °C	density kg/dmc
10	-3.5	1015
20	-8	1032
25	-11.9	-
30	-15.4	1047
35	-19.4	-
40	-23.9	1063
50	-35.6	1077

- Run-around-coil systems must be filled with a water-glycol mixture in the correct concentration.

Check that the system is filled with the correct concentration of glycol.  
In addition, the start-up instructions described for water coils must be observed.

## Water coil

Check that the fluid flow direction through the coil matches the arrows on the coil connections. The direction of the flow must always be such that the water and air are in counterflow.

Incorrect connection will cause a loss of coil capacity. Water batteries are equipped with thin aluminium fins which are susceptible to mechanical damage. A little damage does not affect the exchange capacity of the coil.

However, if the fins are deformed over large surface areas, this could affect performance.

The folded fins can be "combed" with a special tool, so that they can practically return to their original shape.

One comb is suitable for the different fin spacings as shown in the following figure.



Make sure the correct fin spacing is selected when using the comb.

Check that the hydraulic circuit is filled with the correct fluid (water or a mixture of water + glycol) and make sure that the coil and the hydraulic circuit are completely vented (open the vent valves suitably positioned on the highest points of the system until all the air is vented).

The presence of air inside a coil determines the reduction of its exchange capacity and can cause uneven temperatures on its front section.

## Electric heater

Check the electrical connections to the heating elements and the connection of the safety thermostats, on the basis of the relative electrical connection diagrams. Test and check all safety and control devices:

- Safety thermostats
- Flow switch for heater enabling
- Fan switch-off delay (5 minutes minimum)
- Check that there are no paper or other flammable objects left in the section. These could ignite immediately due to the high surface temperature of the elements.
- Check that the drains are made and connected correctly, checking the correct flow of the condensate.
- Provide for the realization of the siphons.
- Provide for an anti-vibration joint between the ducts and the unit.
- Check the correct installation of filters and pre-filters.

After removing the filters from the packaging (they are placed in to prevent deterioration during transport), insert the absolute and active charcoal pocket filters into the containment section, paying attention to ensure a rigid assembly and a perfect seal of the gaskets.

The air filters protect the air handling unit and the ducting system from contamination and have a great impact on the quality of the air in the building.

Inspect the filters to check for any damage in the filter medium and check that the filter modules are installed correctly in the filter frames.

Make sure that the measuring tubes are connected properly and in place and are not kinked or pinched. Keep in mind that the life of the filters is significantly reduced after the initial start-up of the unit due to any excessive loads of dust in the air and the presence of other pollutants inside the building. If the air handling unit was put into operation even during the construction period of the system, we recommend you replace all filters after commissioning, as described below.



There are some precautions that can prevent this problem:

- **Temporary replacement of the filters** included in the supply with epM10 50% (M5) filters. These filters have an adequate capacity to retain dust without clogging immediately (as in the case of epM1 60% (F7) or higher filters). The epM10 50% filters protect the air handling unit and its components adequately, preventing its contamination.
- **Thoroughly clean the building**, the ducts and the air conditioning system, before starting the unit.
  - Check that screws and bolts are tightened.
  - Check that the structure has been earthed.

## Indirect drive fans (belts and pulleys)

- Check the correct alignment of the pulleys
- Check the correct tensioning of the belts.
- Check the condition of the motor and fan bearings, where required.

Check that the wiring is correct and the connection to the service switch terminals or to the frequency converter has been made according to the manufacturer's wiring diagram.

Standard motors can be controlled with a frequency converter. Also check that the electrical system and the connections to the inverter terminals match the supplier's wiring diagram.

Remove any protections for the transport of the anti-vibration supports of the fans and check that the flexible joint is not too loose or too tight.

Check that all nuts and fastening bolts have been sufficiently tightened and that the impeller can be easily turned by hand and does not rub against the inlet cones.

Lubricate the bearings according to the manufacturer's instructions, when necessary and at the prescribed intervals.

### Greases suitable for bearings

Supplier	Type	Base	Temperature interval
<b>SHELL</b>	Alvania Fett 3	Lithium	-30 °C / + 130 °C
<b>ESSO</b>	Beacon EP 3	Lithium	-20 °C / + 120 °C
<b>MOBIL</b>	Mobilux EP3	Lithium	-20 °C / + 130 °C
<b>ENI</b>	CT 350 EP3	Lithium	-20 °C / + 120 °C

Check that the V-belts are properly tensioned and that the fan and motor pulleys are correctly aligned. The alignment can be checked with a steel rod or a thin wire held along the pulleys.

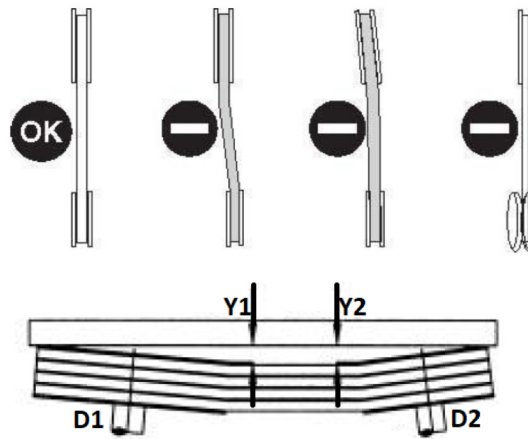

The rod or cable must touch both pulleys fully. The maximum allowed deviation is shown in the following **table 1**

Pulley diameter D1-D2 (mm)	Max distance Y1-Y2 (mm)
< 150	0.5
< 250	1
< 500	2

**Table 1**

The information required regarding the tension of the V-belts is usually indicated on the fan. If this information is missing, the values in the following tables can be used as guidelines.

During the first hours and again, during the first 7-8 days of operation, the tension of the belts must be checked frequently; if these are loose, it is necessary to restore the tension by acting on the belt tensioners (slide type with single screw slider for motors up to 55 kW and two-track type for motors over 55 kW). The tensioning of the belts can be done in the following way:

1. Once the belts are fitted to the correctly aligned pulleys, begin moving the motor on the slide until you notice no significant belt sag.
2. Gradually tension the belts by running the transmissions for some time between one tensioning and the next, until their length has increased to the value indicated in table 2 for each belt type and development.

Tipo e lunghezza cinghia mm Belt type & length	Allungamento mm Elongation	Tipo e lunghezza cinghia mm Belt type & length	Allungamento mm Elongation	Tipo e lunghezza cinghia mm Belt type & length	Allungamento mm Elongation
<b>SPA</b>		<b>SPB</b>		<b>SPC</b>	
750 ÷ 875	5,0	—	—	—	—
900 ÷ 1025	6,0	—	—	—	—
1050 ÷ 1125	7,5	—	—	—	—
1250 ÷ 1425	8,5	1272 ÷ 1522	9,0	—	—
1450 ÷ 1700	10,0	1622 ÷ 1822	10,5	—	—
1718 ÷ 2000	12,0	1922 ÷ 2142	12,5	2030 ÷ 2390	14,0
2018 ÷ 2325	14,0	2262 ÷ 2522	15,0	2530 ÷ 2830	17,0
2378 ÷ 2750	16,5	2672 ÷ 3022	18,0	3030 ÷ 3380	20,0
2818 ÷ 3168	19,0	3172 ÷ 3572	21,5	3580 ÷ 4080	24,0
3368 ÷ 3768	22,5	3772 ÷ 4272	25,5	4280 ÷ 4780	28,5
4018 ÷ 4518	27,0	4522 ÷ 5022	30,0	5030 ÷ 5630	34,0

**Table 2**

The values shown in the table are approximate and refer to standard belts subjected to uniform driving torques and resistances.

It is also possible to use another faster method, but also more approximate than the previous one: thumb pressure.

According to this method, with the help of **table 3** below, a transmission can be considered correctly tensioned when, the diameter of the smaller pulley and the centre distance of the two pulleys known, exerting pressure with the thumb on the centre of the section between the two pulleys, the measured value of the deflection is between the values in the following **table 3**.

<b>TIPO DI CINGHIE / BELT TYPE</b>											
<b>SPA</b>				<b>SPB</b>				<b>SPC</b>			
Diametro puleggia minore Small pulley diameter mm	Interasse puleggie Pulleys centre distance mm	Freccia cinghie Belt camber mm		Diametro puleggia minore Small pulley diameter mm	Interasse puleggie Pulleys centre distance mm	Freccia cinghie Belt cambers mm		Diametro puleggia minore Small pulley diameter mm	Interasse puleggie Pulleys centre distance mm	Freccia cinghie Belt camber mm	
		Tensionamento Tensioning				Tensionamento Tensioning				Tensionamento Tensioning	
		Primo First	Successivi Subsequent			Primo First	Successivi Subsequent			Primo First	Successivi Subsequent
< 100	— —	— —	— —	≤ 160	380 ÷ 510	10 ÷ 13	7,5 ÷ 10	< 250	2030 ÷ 2390	16 ÷ 21	13 ÷ 17
	210 ÷ 310	7 ÷ 9	5 ÷ 7		550 ÷ 660	14 ÷ 17	10,5 ÷ 12,5		2530 ÷ 2830	22 ÷ 26,5	17,5 ÷ 21
	320 ÷ 390	9 ÷ 11	7 ÷ 8		710 ÷ 820	18 ÷ 21	13,5 ÷ 15,5		3030 ÷ 3380	29 ÷ 34	23 ÷ 27
	400 ÷ 460	11 ÷ 13	8 ÷ 9		880 ÷ 1010	22,5 ÷ 25,5	17 ÷ 19		3580 ÷ 4030	36 ÷ 42	29 ÷ 33,5
	— —	— —	— —		1085 ÷ 1260	27,5 ÷ 32,0	20,5 ÷ 24,0		— —	— —	— —
≥ 100 ≤ 140	440 ÷ 560	12 ÷ 15	9 ÷ 11,5	> 160	910 ÷ 1160	22,5 ÷ 28,5	17,5 ÷ 22	> 250	3030 ÷ 3380	20 ÷ 23	16 ÷ 18,5
	570 ÷ 700	15 ÷ 18,5	11,6 ÷ 14	≤ 224	1285 ÷ 1535	32 ÷ 38	25 ÷ 29,5	≤ 355	3580 ÷ 4030	25 ÷ 30	20 ÷ 24
	710 ÷ 800	18,5 ÷ 21,5	14 ÷ 16	1660 ÷ 2030	41 ÷ 50	32 ÷ 39	— —	— —	4280 ÷ 5030	32 ÷ 40	25,5 ÷ 32
> 140 ≤ 200	790 ÷ 850	18 ÷ 21,5	14,5 ÷ 17	> 224	1060 ÷ 1360	20 ÷ 26	15,5 ÷ 20,5	—	— —	— —	— —
	960 ÷ 1160	21,5 ÷ 26	17 ÷ 21	≤ 335	1485 ÷ 1860	28 ÷ 35	22 ÷ 27,5	—	— —	— —	— —

**Table 3**



---

**DANGER!**

While working on the motor-fan unit, although the unit has been previously disconnected from the power supply, pay close attention to the pulleys and transmission belts and not to leave your hands and fingers under the belts.

---

Now check the direction of rotation of the fan by switching it on briefly. If the direction of rotation does not match the direction of the impeller arrow, reverse the direction of rotation by swapping 2 phases on the motor connection.

- Check the direction of rotation of the motor/fan.



Plug fan

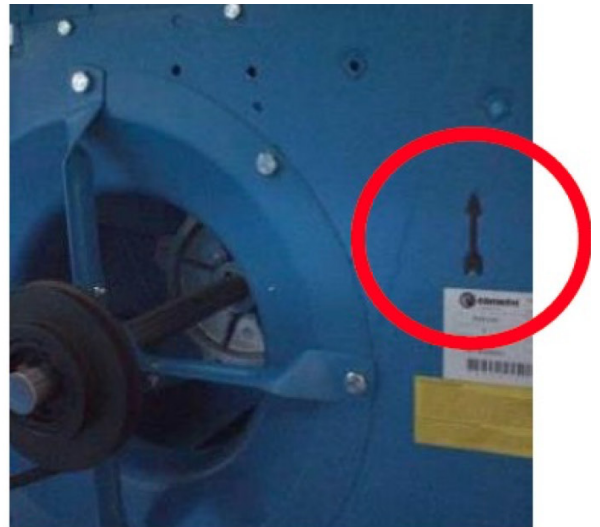

Double inlet fan

In case of wrong direction of rotation, invert the connection of two power supply phases on the motor input terminals.



**N. B.:** If there is an inverter, the rotation of two phases upstream of the inverter does not produce any effect.



Check that the connections and the motor current draw are correct.



Do not start the motor-fan units without first checking the completion of the machine connections with all the necessary ducts.



A few moments after the first start-up, check the absorbed current value, which for no reason must exceed that of the motor plate.



Check the correct operation of the dampers, checking that the fins of the dampers themselves can rotate freely and do not rub against the housing, ducts, flexible joints or there are other obstacles. Ducts and anything else must not weigh on the dampers, but must be supported and held in position by special brackets.



Check that the actuators open and close the dampers correctly.

Check the opening both of the dampers inside the unit and of any external shutters.

Closed dampers can cause excessive pressures / negative pressures in the air handling unit or in the duct system if the fan is on.

The closure of one or more dampers can seriously damage the structure of the unit itself, the air distribution ducts and also the exchange pack of a plate heat exchanger (both cross-flow and counter-flow).



Before start-up, if there are shutters with class 4 air loss, according to EN 1751, these must be lubricated in all joints with a suitable lubricant with high adhesion and life.

- Check that all the electrical components, such as microswitches, disconnectors, lights, pressure switches, probes, inverters, etc. are connected correctly and powered.

- Remove any foreign materials from inside the unit.

- Check and keep the inside of the unit adequately clean.

- Check the integrity of the anti-vibration supports and other components.

## Humidifiers

Due to the wide variety of humidifiers available, refer to the humidifier manufacturer's instructions for start-up and settings.

• Tests to be carried out

- Check each section of the air handling unit to see if there are any objects or sheets left inside.

- Close all inspection openings and make sure that all doors are closed properly.

- Check that all dampers on board the unit, any fire dampers present in the ducts and any external air flow control systems (VAV) are positioned correctly.

After carrying out all the inspections and checks described above, it is possible to start and test the entire air handling unit.

**N. B.** In the absence of fluid circulation, check that there is no danger of the water heat exchange coils freezing.

**N. B.** In the case of steam humidifier, the unit has IP21 protection and must therefore be protected from the weather.

For further precautions, refer to the manufacturer's manual

## Cross-flow and counter-flow heat exchangers

Cross-flow plate and counter-flow heat exchangers are treated similarly. Thus the term “cross flow exchanger” can also be read as “counter flow exchanger”. The pack of a cross-flow exchanger consists of thin aluminium plates and is sensitive to mechanical damage.

Small damages (bent plates) are easy to repair by hand bending the plates back to their original shape. Check the gaskets/seals between the exchanger and the walls of the air handling unit. The seals can shift slightly during transport. For exchangers equipped with bypass and/or recirculation damper



Check that the blades of these dampers rotate easily and do not rub against the housing and that the actuators open and close these dampers fully.

Dampers that work incorrectly can have a very negative effect on the efficiency of the exchanger and on the energy consumption of the unit.

## Rotary heat exchangers

A rotary heat exchanger has seals along the circumference of the wheel and radially to limit the loss between the two air flows.

These seals are made with brush type seals.

The gasket placed on the circumference can be fixed to the rotor or to the frame, depending on the wheel manufacturer. These brushes are fixed with screws with slots to allow their adjustment.



Therefore check that these brushes ensure the correct seal between frame and wheel, without causing excessive friction. The seals can move during transport and therefore must be readjusted at start-up.

The best way to check their condition is with the wheel running. If so, adjust them.



## Purging sector

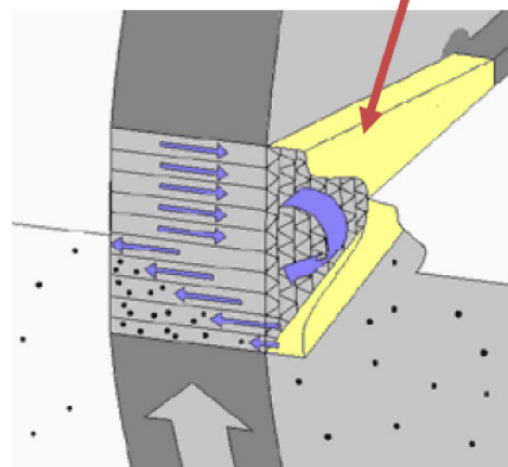

Furthermore, the exchanger can have with a purge sector, which ensures that the rotor matrix is cleaned with fresh air before the rotor portion moves into the delivery sector.

## Transmission belt replacement

The rotary heat exchanger is driven by the **motor (4)** with the **belt (2)** running over the **pulley (3)** and over the circumference of the **rotor (1)**.

The tension on the belt is maintained by the **spiral spring (6)** under the motor **mounting plate (5)**, hinged to the frame. Not all models are equipped with pre-tensioning springs.

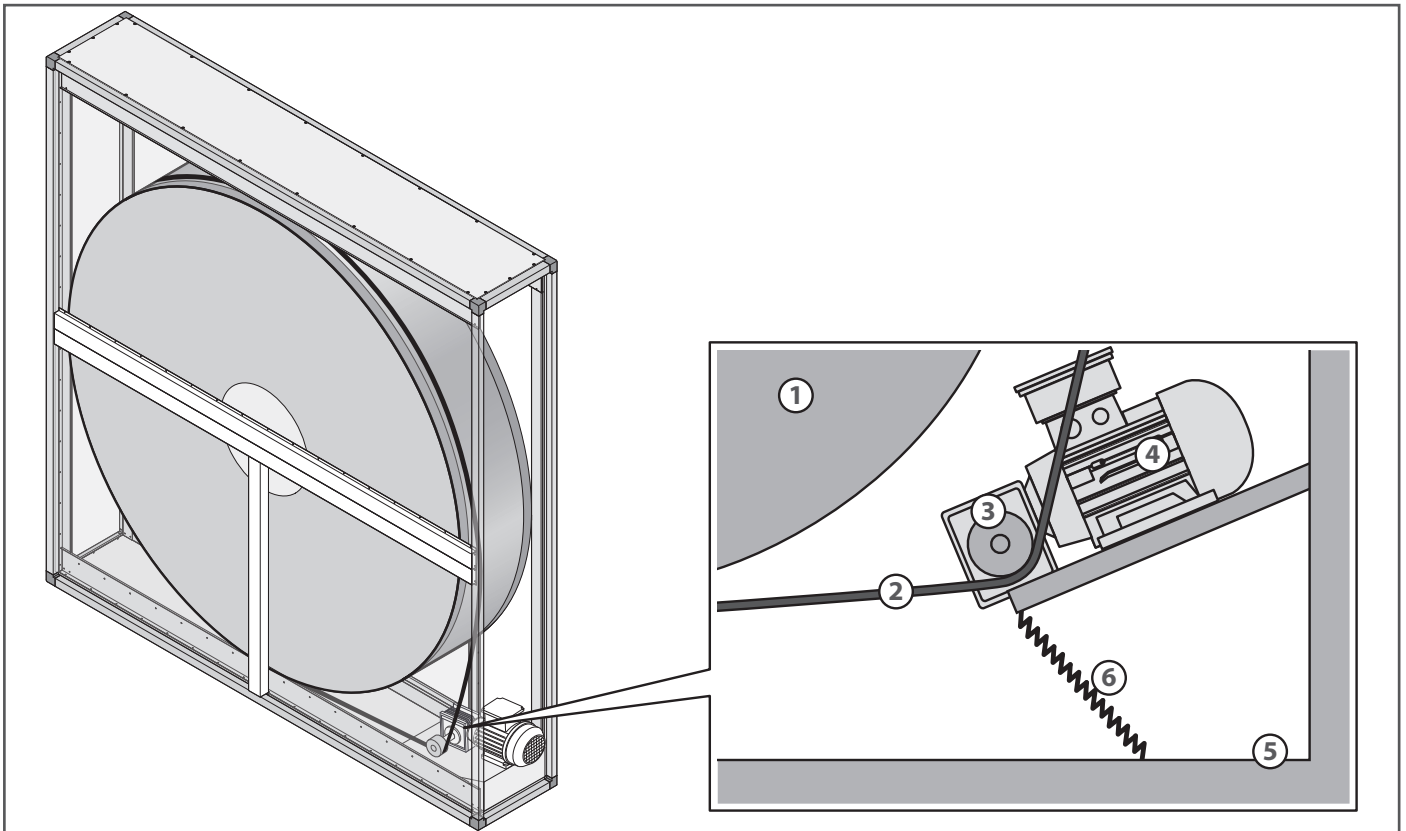

If it is necessary to increase its tension, this can be done removing the belt joint plate and cutting a small portion of the belt itself.

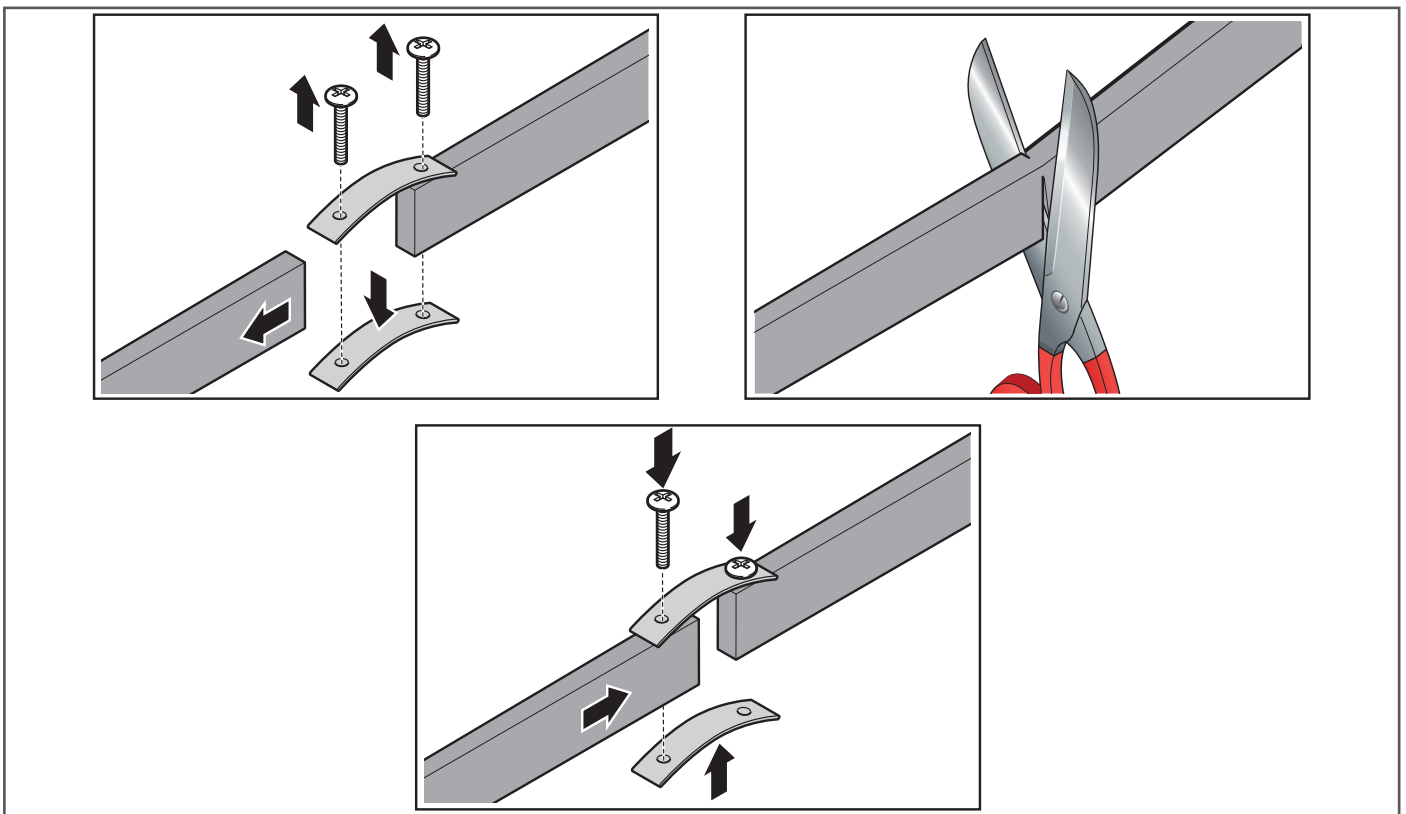

The direction of rotation of a rotary heat exchanger with purge sector must be chosen in such a way that the rotor rotates from the purge sector of the exhaust air to the intake air.

In the illustration, the **pulley (3)** rotates clockwise.

The belt pulling part of the no-bleed rotary heat exchangers should match the centre line through the tension spring as much as possible. The direction of rotation is generally indicated on the rotary heat exchanger. The direction of rotation must be checked at start-up! The direction of rotation can be reversed by exchanging two phases on the electrical connection to the motor (in the case of direct motor power supply).

## Power supply

### Direct supply

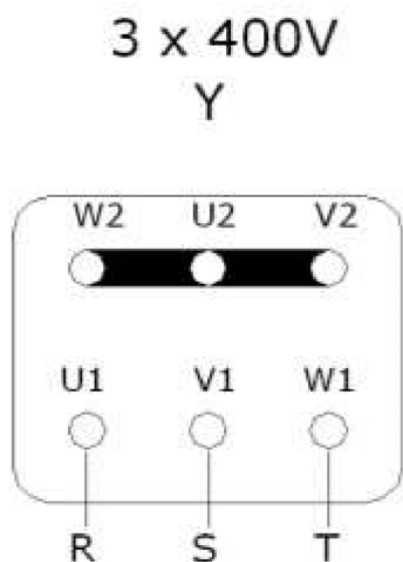

### Powered by VFD or Micromax

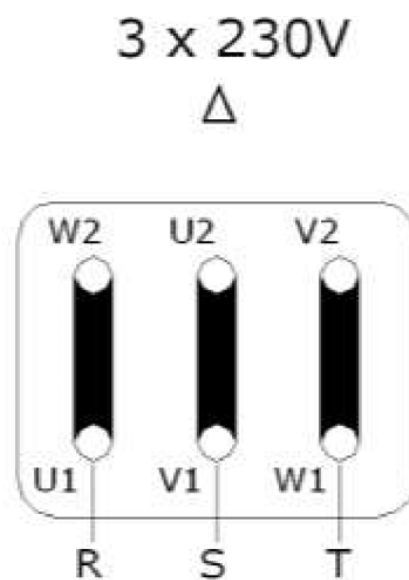

For alignment operations of the rotary wheel and general maintenance operations, refer to the manufacturer's manual supplied.

## Power Twist Belt transmission belt replacement

If there is a **Power Twist Belt** type transmission belt, proceed as follows:

### Measurement

To check the hand-tightened section, it is necessary to tighten the belts around the pulleys, overlapping (in the hand-tight section) the last two tabs with two holes in the corresponding links, as shown in the illustration below; then mark the tabs as shown.

Count the number of links and remove one link every 24 sections.

In this way, a belt of the correct length is obtained and optimum tensioning is ensured during operation.

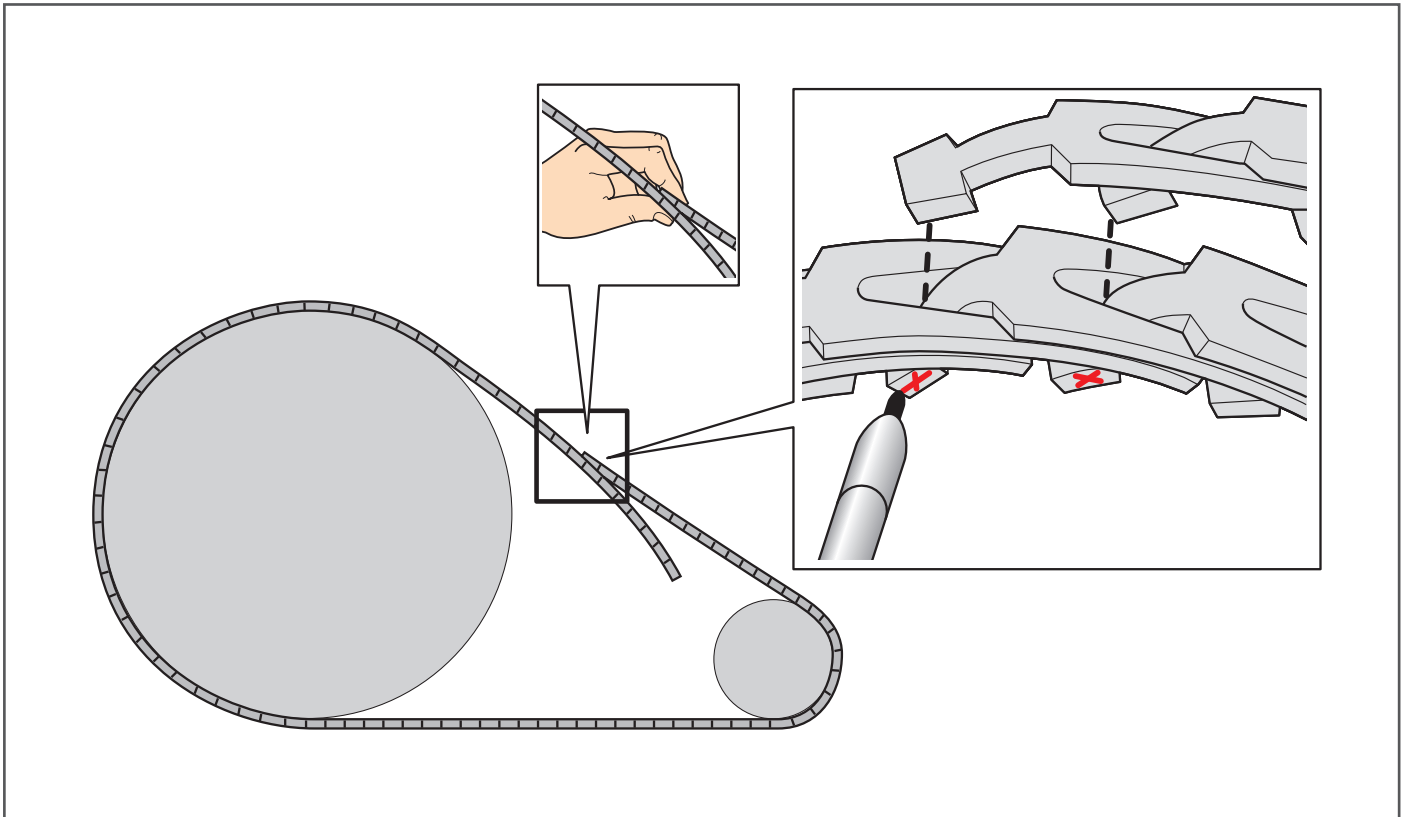

Note: one link every ten has an arrow.

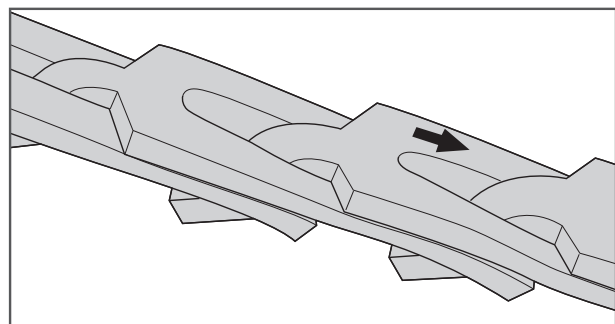

## Link separation



For easier separation of the links, it is advisable to rotate the belt 180° as illustrated below.

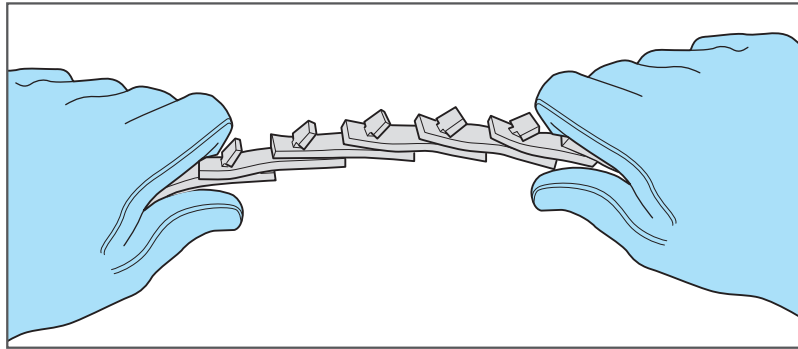

Fold back the belt and grasp it with one hand. Then rotate the first tab 90° parallel to the slot.

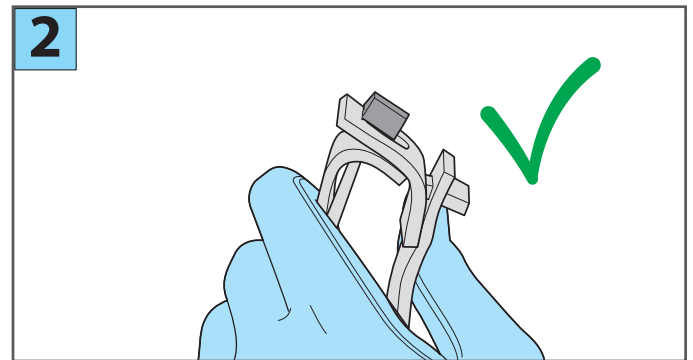
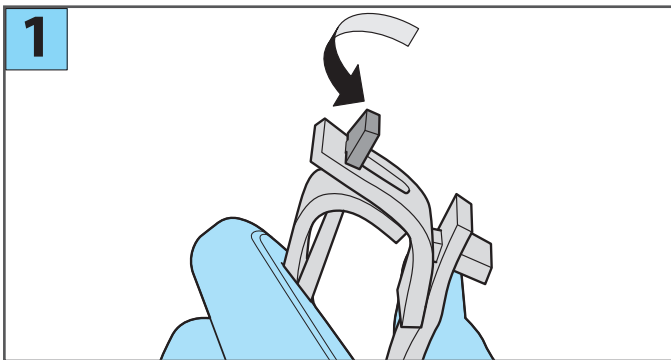

Lift the end of the highlighted link.

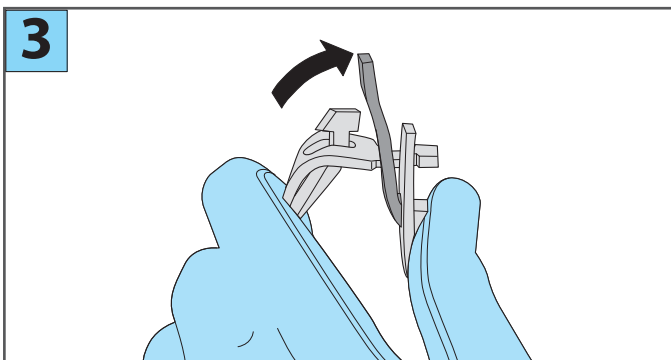

Then rotate the link and tab as shown.

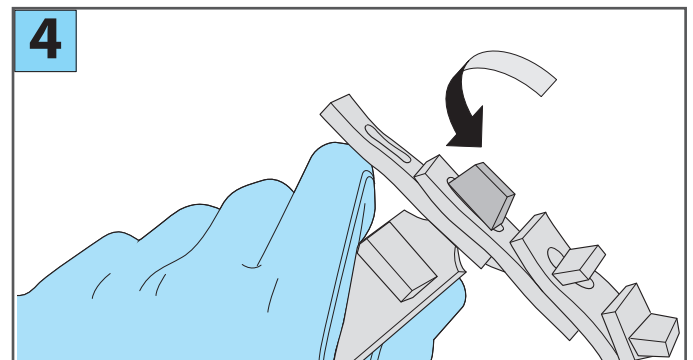

At this point it will be possible to remove the link.

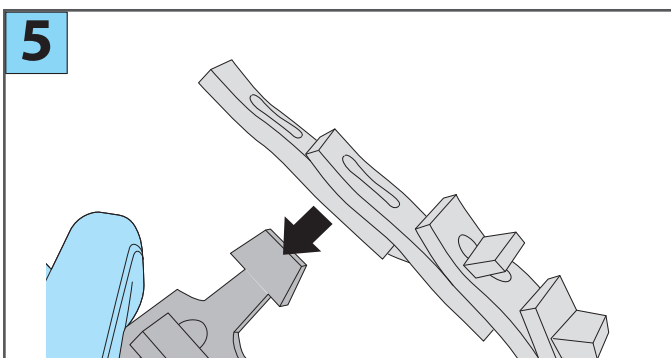

## Mesh connection



For easier connection of the links, it is advisable to rotate the belt 180° as illustrated below.

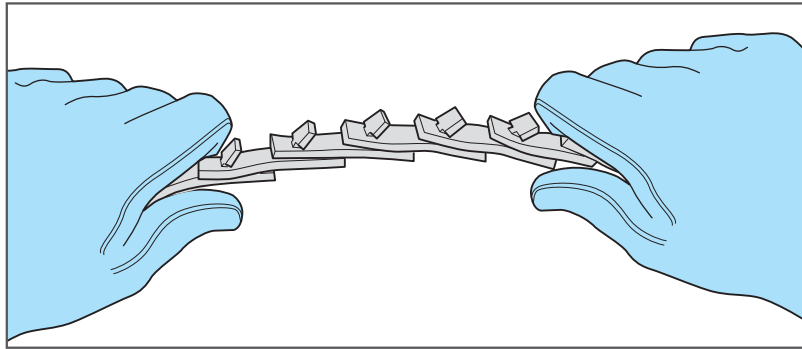

Insert the tab into the two overlapping links as shown.

Then rotate the link and tab as shown.

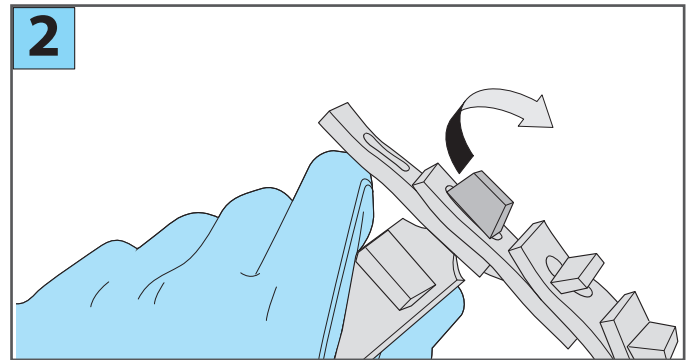
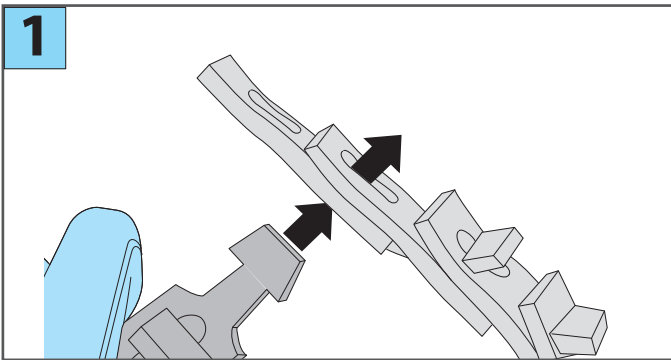

Grasping the belt with one hand, take the highlighted link and insert it into the tab below.

Then rotate the tab as shown.

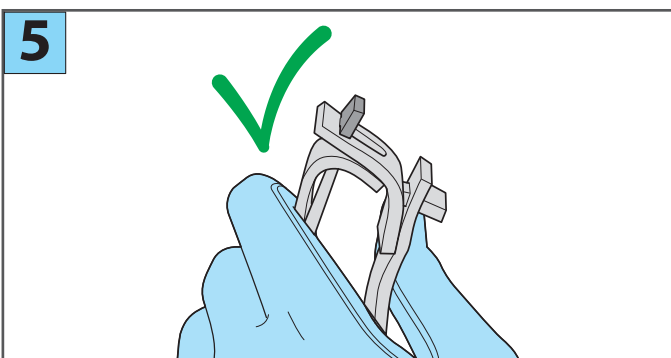
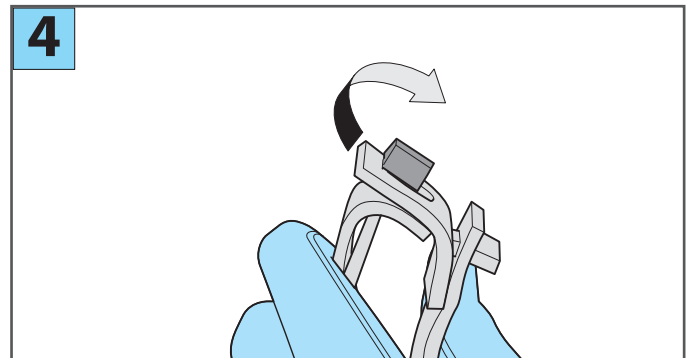
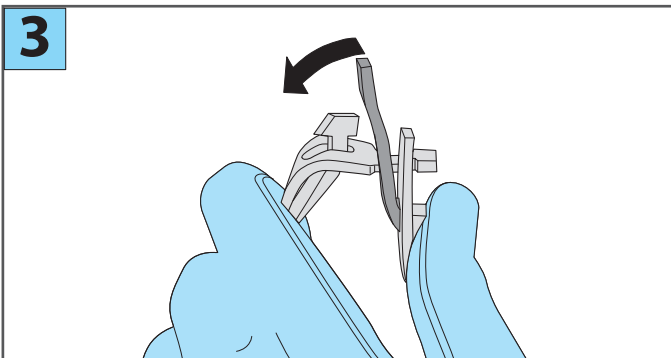



## Installation

1. Before proceeding with the installation, turn the belt so that the tabs are inside
2. Identify the direction of rotation of the transmission

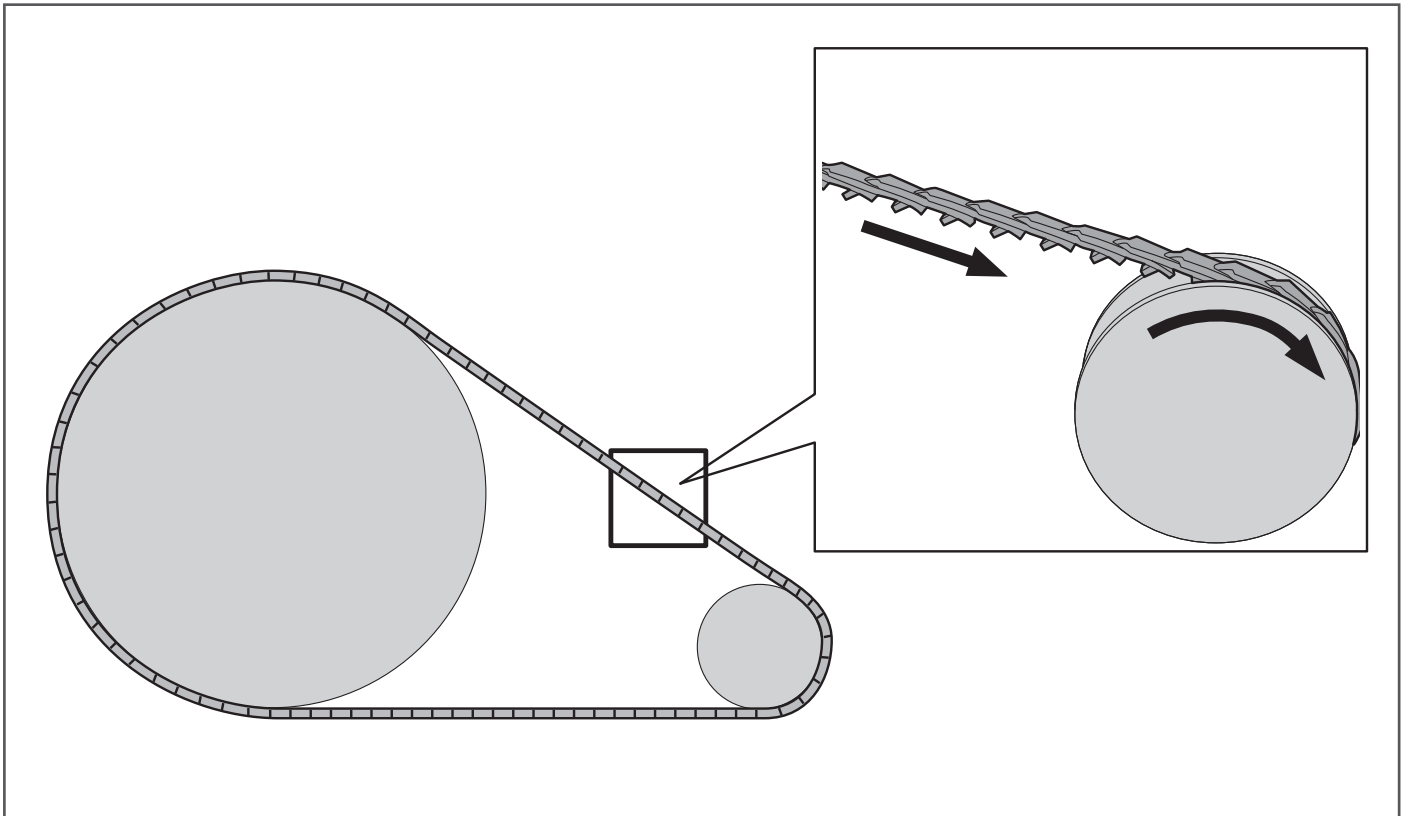

3. The belt should turn with the anchors following the direction of the arrow.

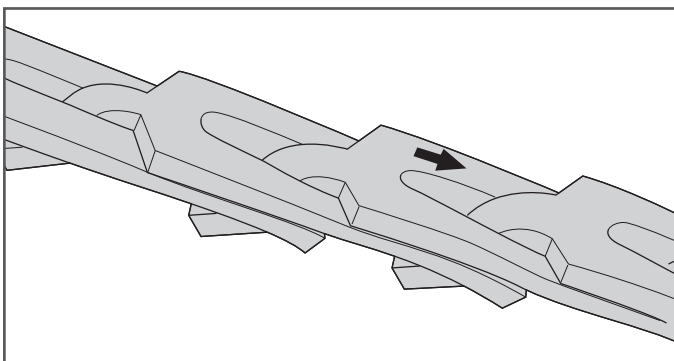

4. Insert the belt into the nearest groove of the smaller pulley.
5. Wind the belt onto the largest pulley slowly rotating the transmission. The belt can also feel very tight, but this is not a problem.
6. Check that all tabs are always in the correct position and are not misaligned.

## Tension adjustment

For the PowerTwist belt to work efficiently, the drive tension must be kept within the correct limits. Check the transmission tension between 30 minutes and 24 hours of full operation.



Check the belt tension periodically and adjust as needed.

Once the operations to set up the machine after installation have been carried out, it is possible to proceed with the commissioning of the machine.

To avoid damaging the machine, make sure that the machine's dampers are in the correct position. If the machine has motorized dampers and their opening is automatic and managed by the control unit on the control panel, check that they open.

To avoid damage to the battery, caused by ice, it is advisable to fill the water circuit with antifreeze liquid or completely empty the battery if the air temperature can drop below 3°C.



**To perform the activities listed in this chapter 7, the Personal Protective Equipment listed in chapter 1 is required.**

## Rotary heat exchanger alignment adjustment

**Instructions valid for Recuperator products.**

**There are no wheel adjustment devices for Hoval recuperators.**

### Wheel alignment

Visually check whether, after having isolated the motor electrically, turning the heat exchanger by hand, it exhibits any lateral movement.

The tilt of the rotor can be adjusted through the screws on each side.

**- For rotors between Ø 500 mm and Ø 1350 mm**





1) Loosen the 4 screws (photo A)



2) Adjust the toe-in of the wheel using the vertical bolt (photo B)



1) Loosen the two screws (photo C)

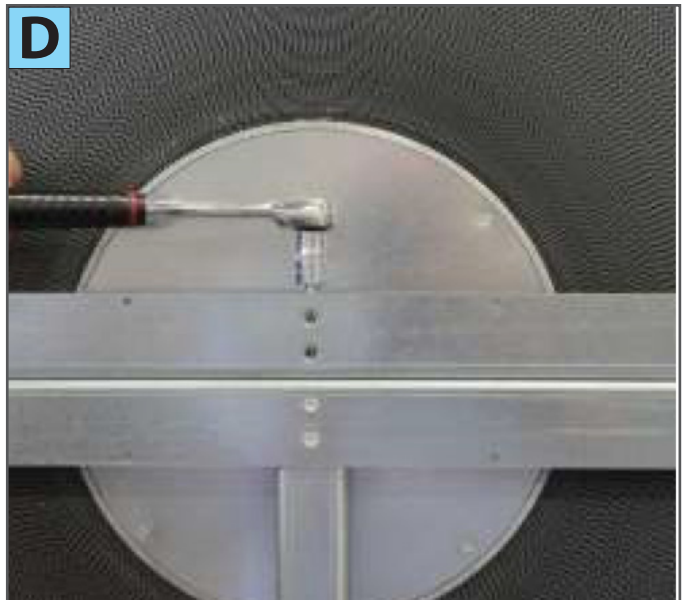

2) Adjust the toe-in of the wheel using the vertical screw (photo D)

- For rotors between  $\varnothing 2000$  and  $\varnothing 2400$  mm

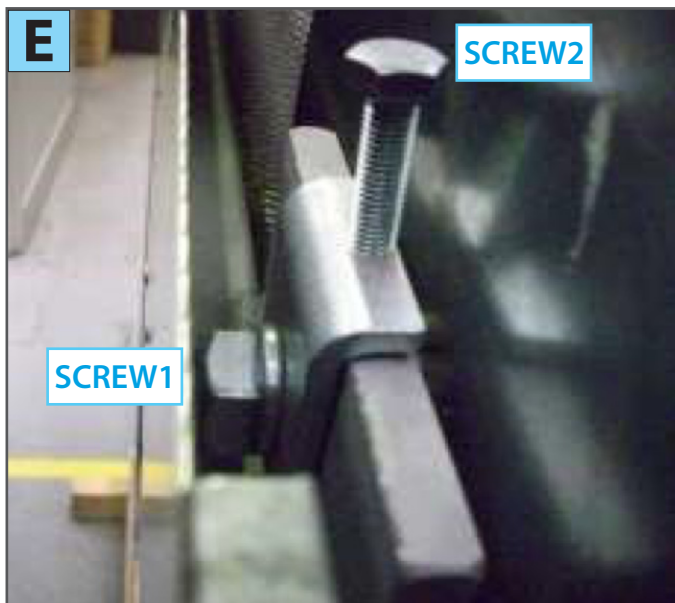

1) The two adjustment screws are located in the centre of the rotor (photo E)

2) Loosen screw 1 (photo F)



3) Adjust the toe-in of the wheel through bolt 2 (photo G)



4) Tighten bolt 1 (photo H)

5) Check the bolt on the opposite side is tight

At the end of the adjustment, the distance between the wheel and the frame must be  $15 \pm 5$  mm on both sides.

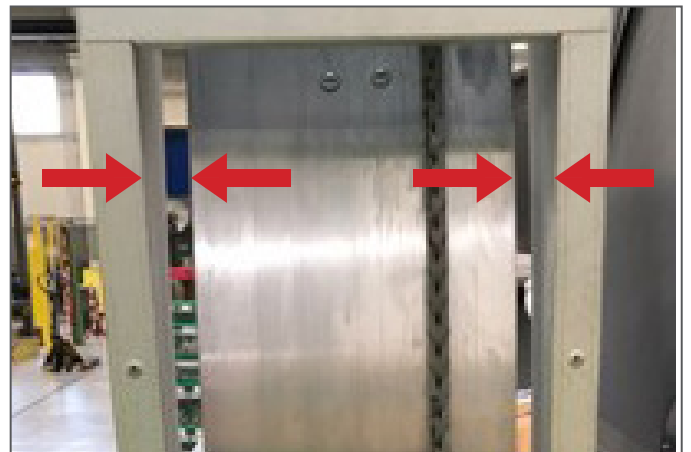

## Checking the unit safety devices



**Checking the efficiency of the safety devices fitted on the machine MUST be carried out prior to commissioning.**

Use the following procedure:

- Open one of the inspection doors fitted with a microswitch on the machine.
- Check it is impossible to start the machine.
- Close the door and open another door fitted with a microswitch. Repeat the operation for all interlocked inspection doors, checking each time that the machine cannot be started.
- Similarly, press the emergency button on the outside of the control panel and check that the machine cannot be started.

# Use of the unit



It is essential, for the correct operation of the unit and to avoid probable breakages, to open the dampers before starting the ventilation.



Q. E. Professional STD

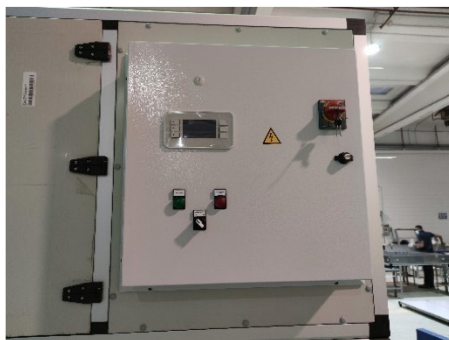

Q. E. Prof. Light Control



Q. E. Digital

The sequence that leads to the **automatic start-up of the unit** is as follows:

- Open the electrical panel;
- Power the unit by acting on the general disconnecter;
- Carry out the programming necessary for the correct operation of the unit;

The unit does not require further intervention by the operator as it has automated start-up and shutdown and is managed by the controller.

If you want to permanently turn off the controller, you must turn off the automatic management and intervene at the general disconnecter.

## Section electrical connection for Digital Plug & Play units

For the electrical connection of the sections of the Digital Plug & Play units, pay particular attention to the coupling direction of the connectors as shown in the images below:



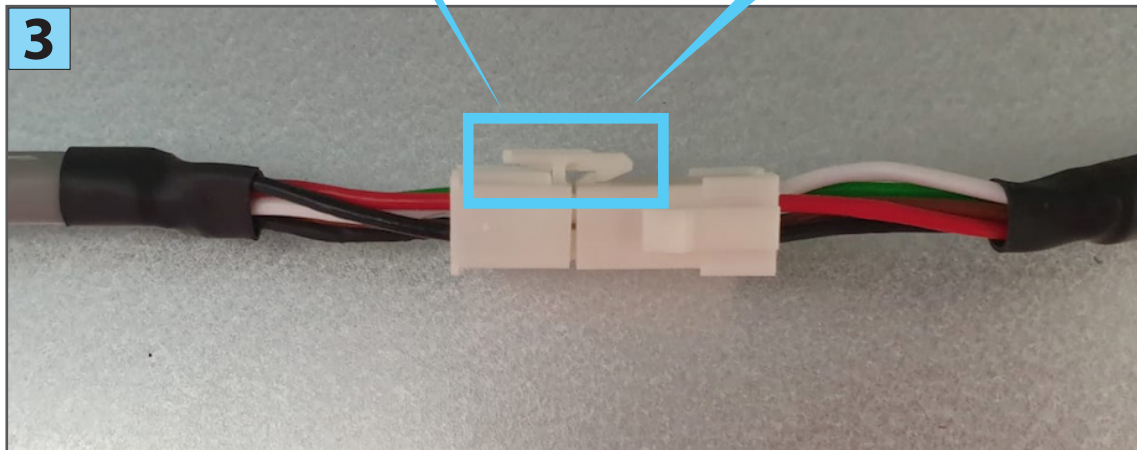
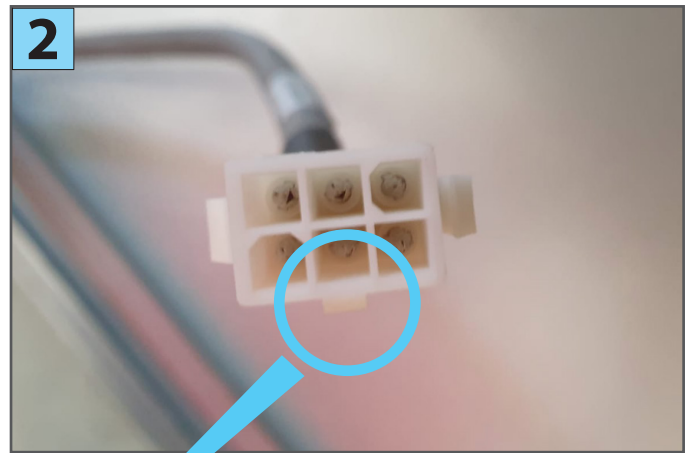
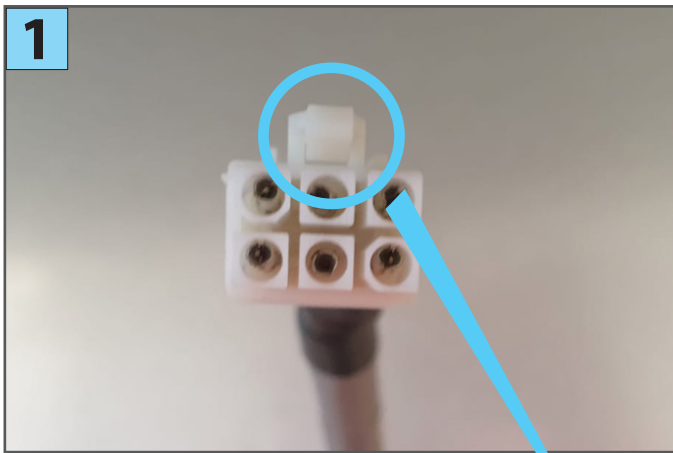

## Digital board LED indicators

The electrical components can be installed on the digital boards present in the section of the component itself. On the case of these boards there are 6 board status indicator LEDs which light up when the board is powered.

LED1 = green = ON

LED2 = red = hardware failure

LED3 = yellow = I/O error

LED4 = blue = connection OK

LED5 = yellow = connection timeout between the board and the controller

LED6 = red = unit in alarm



# Pressure tap configuration (as from factory)

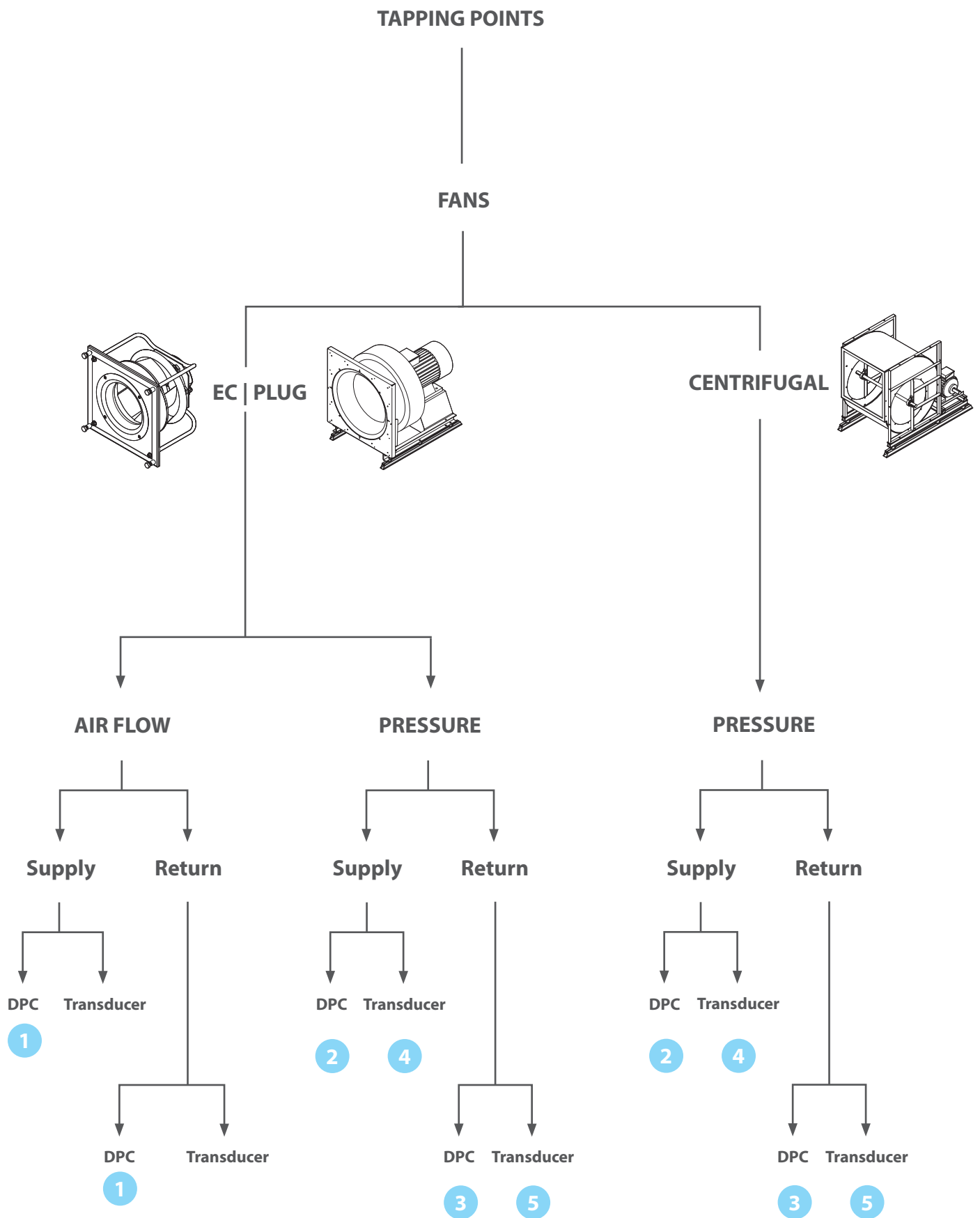



# 1 Supply control | AIR FLOW return

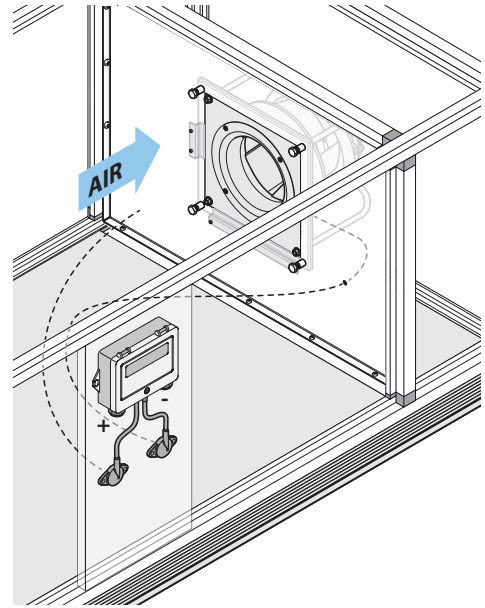
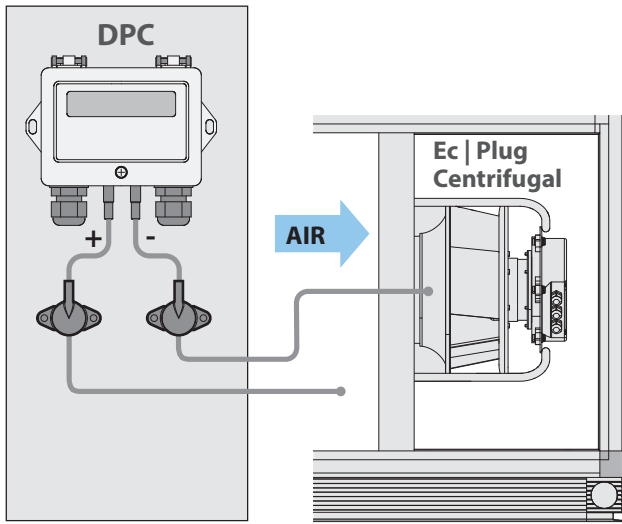

# 2 PRESSURE supply control

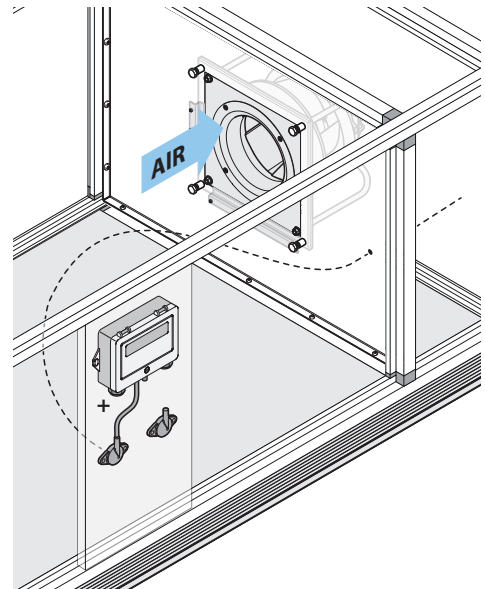
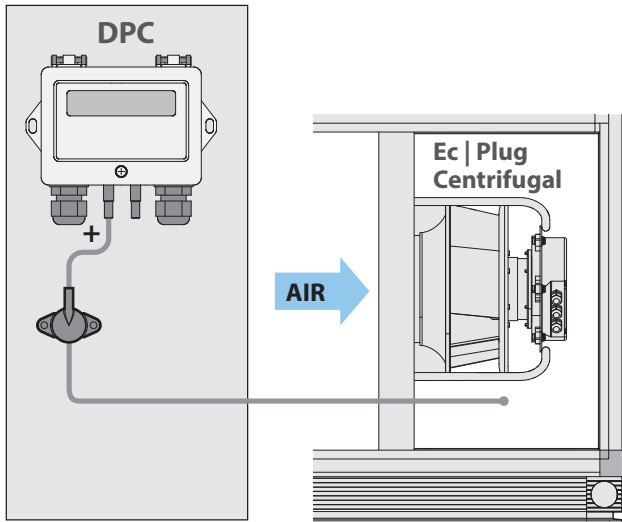

# 3 PRESSURE return control

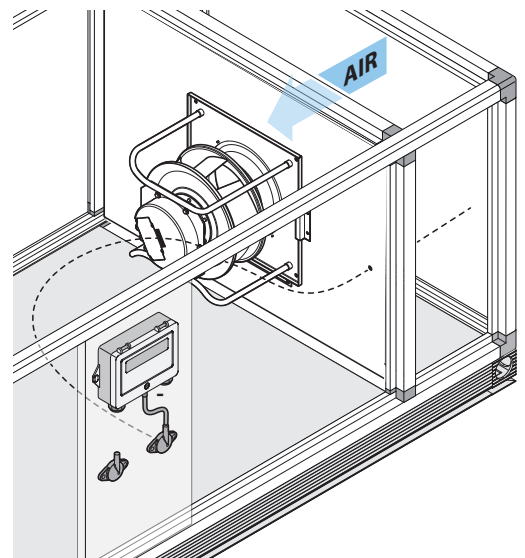
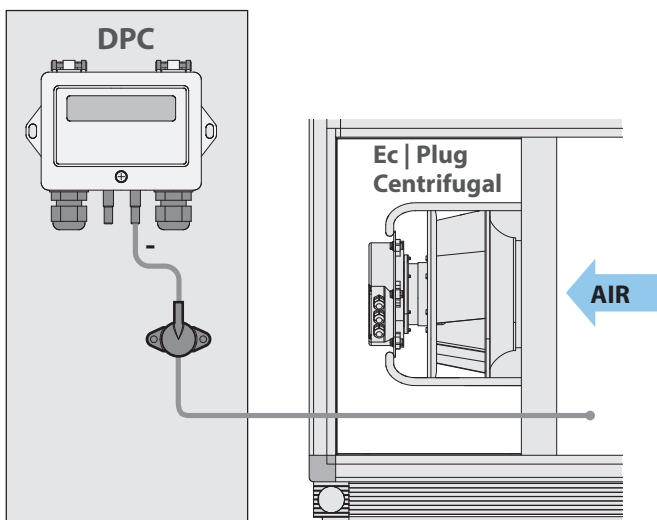

4

### PRESSURE supply control

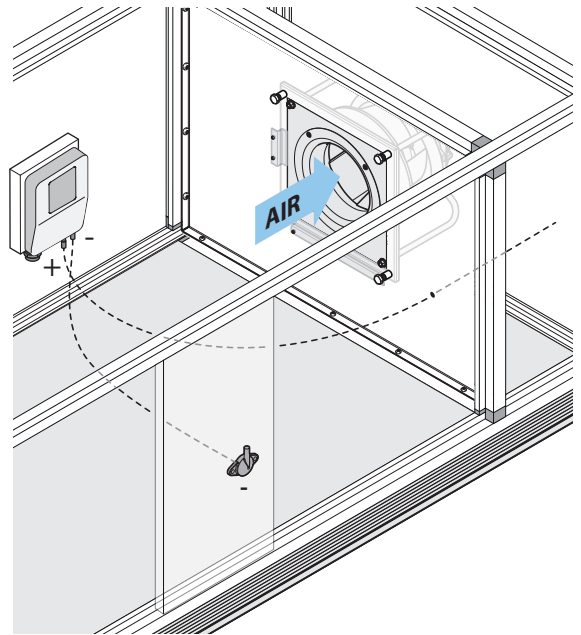
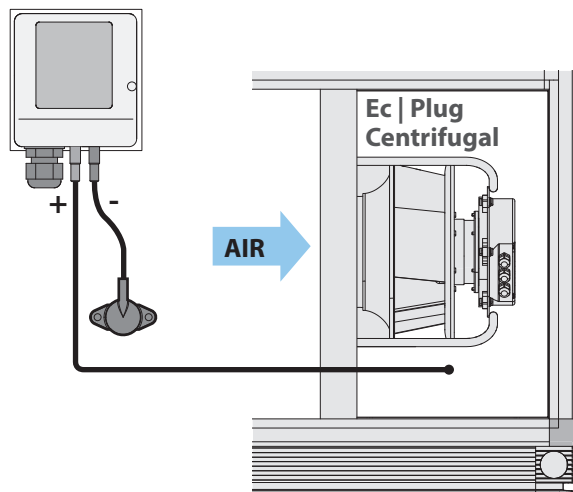

5

### PRESSURE return control

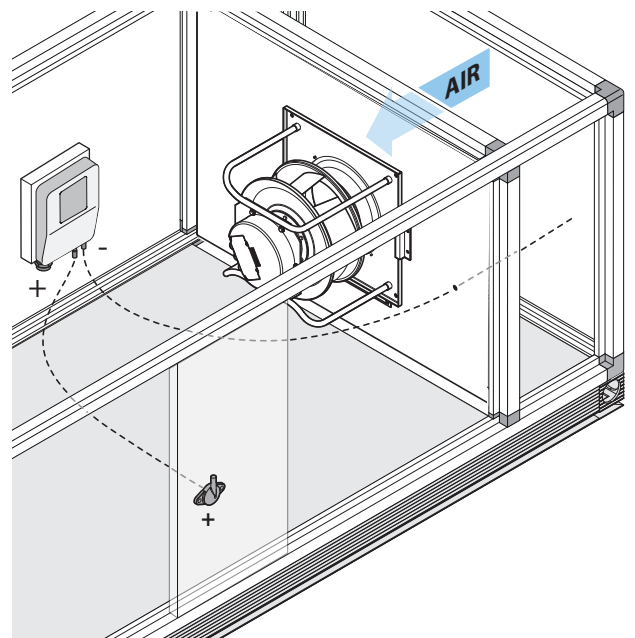
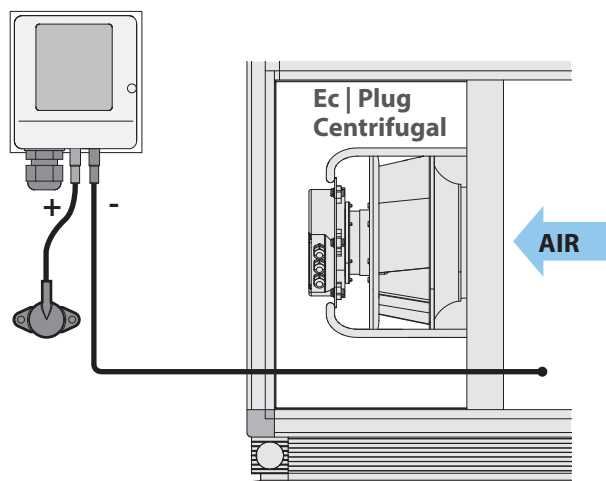

+2 TAPPING POINTS

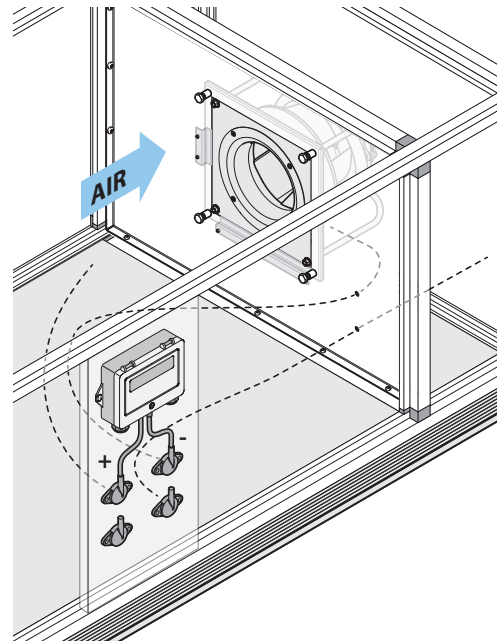
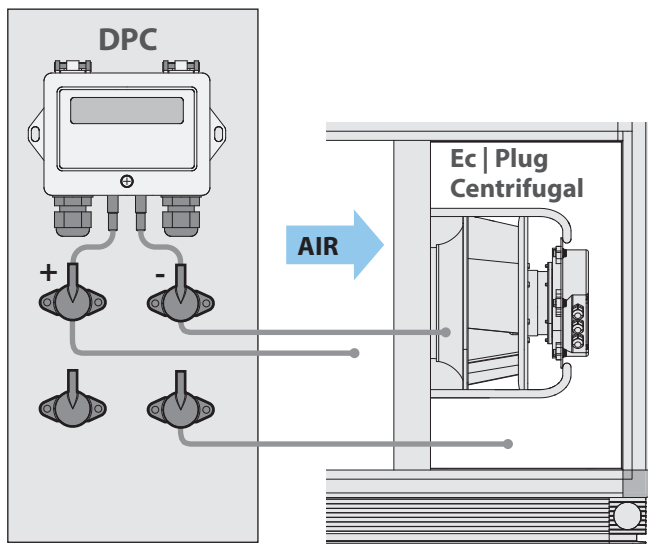

+3 TAPPING POINTS

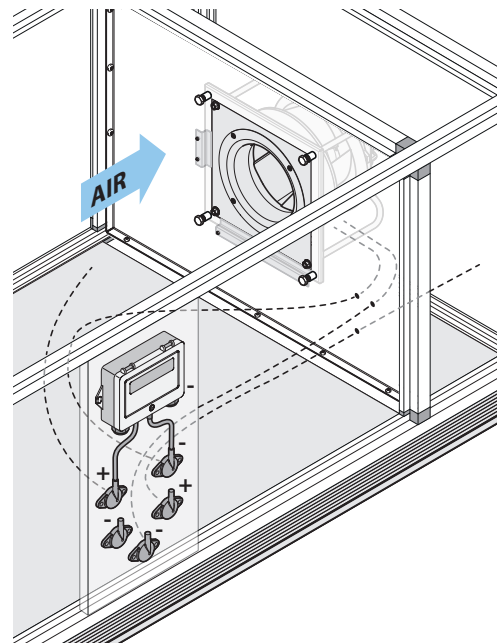
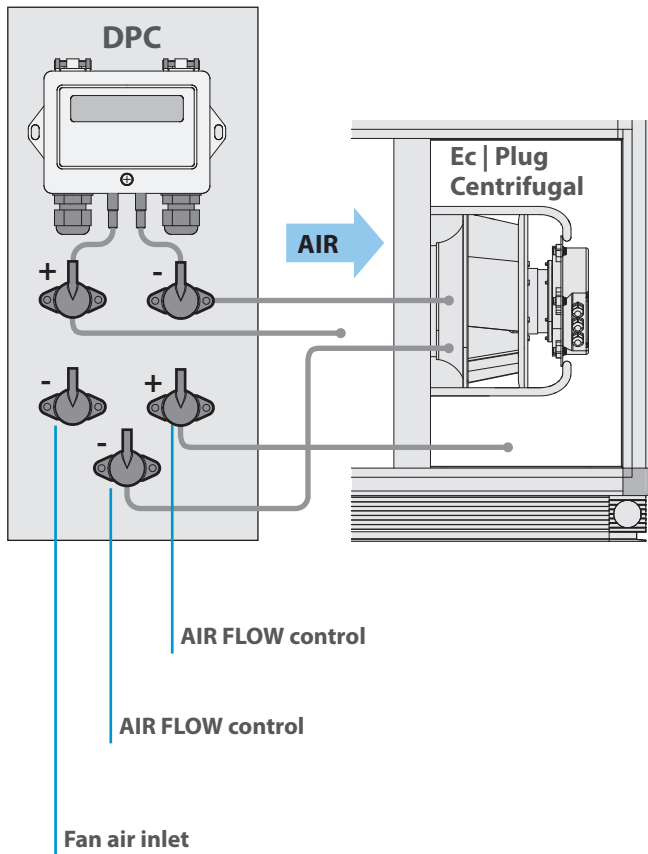

SINGLE FILTER

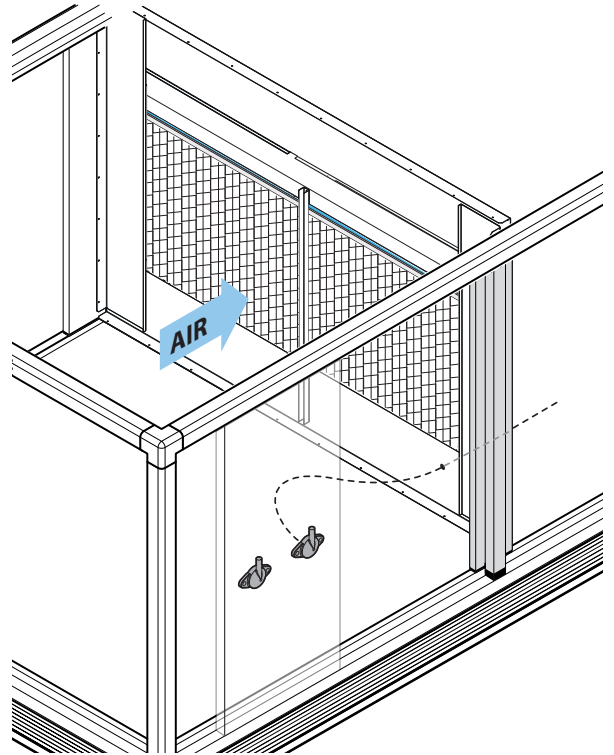
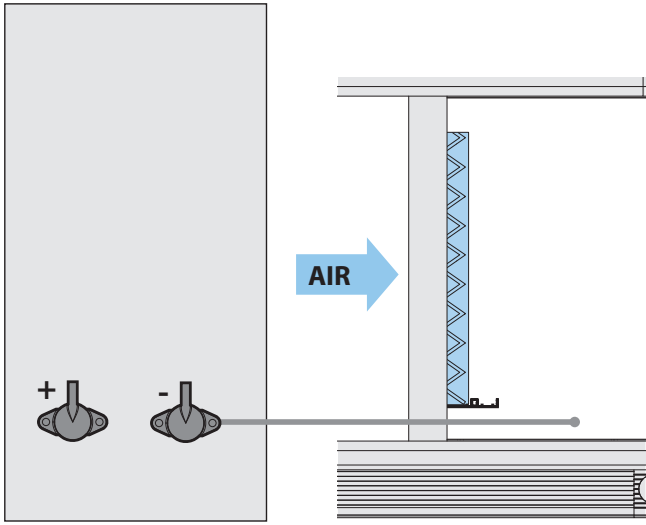

DOUBLE FILTER

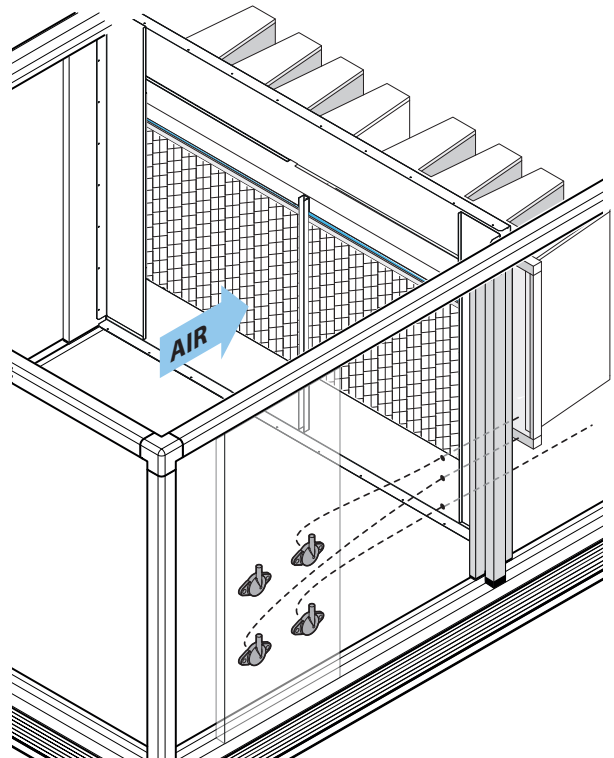
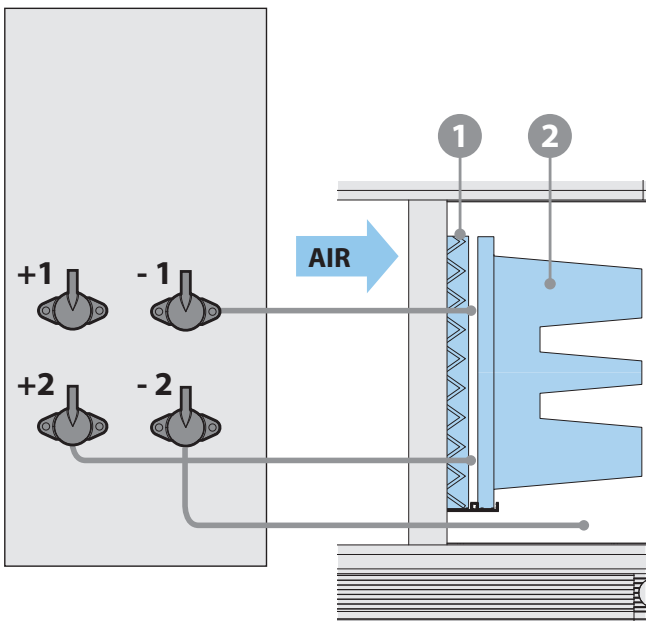



# 8 Maintenance

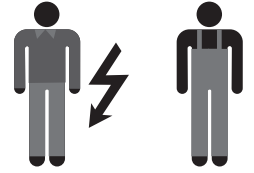

## Safety precautions for maintenance



Ordinary and extraordinary maintenance must be carried out **solely by the operator assigned to perform maintenance** (mechanical and electrical maintenance staff) according to the regulations in force in the country of use and respecting the laws regarding systems and work safety. Remember that, by operator assigned to perform maintenance is meant the person who can work on the unit to perform ordinary and extraordinary maintenance, repairs and fine tuning. This person must be an expert operator, properly instructed and trained, given the risks involved in such operations.



Before performing any ordinary and extraordinary maintenance, the unit **must always be stopped (by disconnecting it from the mains)** turning the master switch OFF. The switch must have a key that must be removed and held by the operator who will perform the operations until the end of the maintenance itself.



**It is absolutely prohibited to remove any protections** from moving parts and unit protection devices with the unit connected to the mains or operational. Adjustments made with safety devices disengaged must be performed **by a single person**, expert and authorised, and during this activity it is necessary to prevent access to the area of the unit by other people. Upon completing the adjustments with safety devices disengaged, the protections must be re-engaged as soon as possible.



During maintenance the operational space surrounding the unit for a distance of 1.5 metres must be free of obstacles, clean and well lit. It is prohibited for unqualified people to pass through or remain in this space.



Use personal protective clothing (safety shoes, safety glasses, gloves, etc.) compliant with regulations.



Before carrying out repairs or other work on the unit, **always declare out loud** your intentions to other operators who are located in the unit area and make sure that they have heard and understood the warning.



When carrying out maintenance operations with the doors open, **never enter the unit and close the access doors behind you.**



# Ordinary maintenance

The most significant and important operations relating to ordinary maintenance can be summarized as follows:

- Periodic check of the cleanliness of the filters.
- Check of the correct alignment of the pulleys.
- Check of the correct tension of the belts.
- Check of the control and regulation bodies

The indications given in the previous chapter 7 "Control instructions and preparation for starting the unit and its maintenance" remain valid

The proper maintenance of the systems maintains efficiency (reducing costs), consistent performance over time, and increases the usable life of the equipment.

Below is a table listing the indicative time intervals relating to the main inspection activities and any replacement of consumable components. As stated above, these are indicative times that may differ in relation to the severity of the operating conditions of the unit (temperature, humidity, degree of cleanliness of the treated air, etc.).

ACTIVITY	FREQUENCY			
	A	B	C	D
General cleaning of the machine.		√		
Check and possibly disassemble and wash flat filters.				√
Replace the filters (when they are clogged or deteriorated).	<b>in case of alarm</b>			
Clean the finned surfaces of the heat exchange coils (if present) with a jet of compressed air and a soft brush and/or low pressure steam and/or hot water under pressure (pay attention to the direction of the water jet, which must be parallel to the fins, therefore perpendicular to the battery crossing surface, to avoid bending and deforming the fins themselves)	√			
Clean the heat recuperator exchange surfaces with a jet of compressed air and a soft brush and/or hot water under pressure (the water jet must be perpendicular to the crossing surfaces of the recuperator itself, so as not to compromise its integrity)	√			
Empty and clean the condensate drain pans.		√		
Visual inspection for corrosion, limescale, release of fibrous substances, any damage, abnormal vibrations, etc. (if possible, it is advisable to extract the components for a more thorough inspection).			√	
Check condensate drain and cleaning of siphons.		√		
Check the status of anti-vibration connections.	√			
Check the tightening of the terminals of the electrical power parts		√		
Check tightness of screws and bolts in the fan section.	√			
Check the ground connection.		√		
Check and grease the bearings of motors and fans, if specified by the manufacturer		√		
Check the fan impeller and its devices, removing any dirt and incrustations	√			
Check the integrity and tightness of the connection tubes of pressure gauges, switches and transducers		√		
Check the mechanical tightening of actuator hub/damper shafts and that the rotation is correct		√		
Check the correct operation of the antifreeze thermostat, if present	√			
Check the SPZ / SPA / Power Twist Belt tensioning of the rotary heat exchanger, if present		√		

**A: annual / B: half-yearly / C: quarterly / D: monthly**

## General information on cleaning procedures



Read the safety instructions at the beginning of this manual.



You should consult with your supplier of chemical products to choose the most suitable for cleaning the unit components.



For the cleaning method refer to the instructions of the detergent manufacturer and carefully read the safety data sheet (SDS).

As general guidelines, refer to the following rules:

- Always use personal protection (safety shoes, safety glasses, gloves, etc.).
- Use mild products (pH between 8 and 9) for washing and disinfecting, in normal concentrations. Detergents must not be toxic, corrosive, flammable or abrasive.
- Use a soft cloth or bristle brushes that do not damage the stainless steel surfaces.
- If you use water jets, the pressure should be less than 1.5 bar and the temperature must not exceed 80°C.
- For cleaning components like motors, damper motors, bearings, pitot tubes, filters and electronic sensors (if applicable), do not spray water directly on them.
- After cleaning make sure that you have not damaged the electrical parts and the seals.
- Cleaning operations should not involve the lubricated parts, like rotation shafts, because this could affect their good operation and create problems with durability.
- For the cleaning of finned components or dampers use an industrial vacuum cleaner and/or a compressor. Attention, the compressed air flow must run opposite to the direction of the airflow through the unit and parallel to the fins.

### Cleaning lamellar components

Remove the dust and fibres with a soft bristle brush or a vacuum cleaner.



Be careful when cleaning with compressed air because the exchanger package can be damaged. Cleaning with pressure jets is allowed if the maximum water pressure is 3 bar and a flat nozzle is used (40° - WEG 40/04 type).

Oils, solvents, etc. can be removed with water or hot grease solvents, by washing or immersion. Periodically clean the condensate drain tray and fill the drain siphon with water.

To clean plastic components such as tapping points, grommets, cable glands, connecting pipes and clicks, use a cloth soaked in alcohol. We recommend carrying out the operation during the general cleaning of the machine and when replacing the filters.

### Vents

Periodically check that there are no new sources of contamination near the air intake. Each component must be checked periodically for the presence of contamination, damage and corrosion. The seal can be protected with glycerine-based lubricants or replaced with a new one, if worn.



## Exchange coils

### **The coils must be cleaned at the slightest sign of contamination.**

The coil should be cleaned and washed gently to avoid damaging the fins.

For cleaning using a **mild detergent** suitable for the purpose. Do not use alkaline, acidic or chlorine-based solutions.

The batteries can be washed with a slightly pressurised water jet (1.5 bar max): the jet must NOT contain chemicals or microorganisms; moreover the water must be sprayed in the opposite direction to the air flow.

For pertinent accessories, refer to the enclosed documentation.

## Fans

The fans can be cleaned with compressed air or by brushing them with soap and water or with a mild detergent. Finish the cleaning by rotating the impeller by hand to confirm the absence of abnormal noises.



**N.B. check frequently the cleanliness of the fans serving environments with polluted air to be extracted (dust, oils, greases, etc.). The accumulation of pollutants on the impeller can cause imbalance and consequent malfunctions and/or breakdowns.**

## Cleaning filters



**The unit must NOT be running when the filters are removed to avoid drawing in outside air that might be contaminated.**

The filters must be cleaned often and carefully to prevent dust and microbial buildup. Usually, compact filters can be cleaned **two or three times** before they are replaced. As a general rule, replacement is required after 500--2000 hours of operation (it varies depending on the type of filter, refer to the Manufacturer's instructions), but may need to be replaced much sooner according to requirements and degree of clogging.

Compact filters (G3/G4) can be cleaned using a vacuum cleaner or by blowing on them with compressed air and washing them in water.

### **Only for versions with up-and-over doors:**

if the opening of the doors is difficult because of the narrowness of the available space, it is possible to remove them by unscrewing the screws that hold them.

At the end of cleaning, it is mandatory to remount the doors.

### **Correct filter and pre-filter installation (in the event of replacement)**

Check the installation of the prefilters located on special counter-frames with safety springs or guides is correct. After removing the filters from the packing (that they are placed in to prevent deterioration during transport and at the installation site), insert them into the containment section, paying attention to ensure a rigid assembly and a perfect seal of the gaskets.



Remove the filters from their packaging only when ready to install them to avoid getting them dirty and contaminating them.



Make sure that the internal part of the filters is not contaminated by external agents. This operation must be carried out about an hour after the first start-up of the machine, a period during which the ducts are cleaned of dust and various residues. Proceeding in this way preserves the filtering sections that cannot be regenerated.

# Extraordinary maintenance

One can not predict extraordinary maintenance as it is normally due to effects of wear or fatigue caused by the incorrect operation of the machine.

## Replacement of parts



The replacement of parts should be performed by expert personnel:

- Qualified maintenance mechanic
- Qualified maintenance electrician
- Manufacturer technician

The machine is designed to be able to perform all the servicing necessary to maintain good efficiency of the components. However, it sometimes happens that a component fails due to malfunction or wear, so for replacement refer to the executive schematic. These are the components that may need replacement:

- Filters
- belts (see starting chapter)
- Motor pulley (if the unit is not equipped with an inverter)
- Fan
- Motor
- inverter
- recovery/heating/cooling batteries

For some of these operations of a general nature we will not enter into detail as these are operations that fall within the abilities and professional expertise of the staff assigned to perform them.

## Consumable components - Spare parts

During the operation of the machine there are particular mechanical and electrical components that are most subject to wear. These parts must be monitored in order to carry out their replacement or repair before they cause problems to the correct operation of the machine with consequent downtime.

Some parts subject to wear

- cell / pocket / activated charcoal filters
- rotary recuperator transmission belts
- Humidification accessories

The annexes will include a sheet listing the parts subject to wear specific to the machine ordered. For special components like bearings, crankshaft, etc., see the specific annexes detailing the technical specifications. To purchase the spare parts needed for normal and/or extraordinary maintenance, contact Daikin specifying the serial number of the machine noted in the documentation and on the machine's plate.

### DEFINITION OF WASTE

Waste is any substance and object deriving from human activities or natural cycles that is abandoned or destined to be abandoned.

### SPECIAL WASTE

Special waste includes:

- Residues from industrial, agricultural, artisanal, commercial and service processes that in quality or quantity are considered different from municipal waste.
- Deteriorated or obsolete machinery and equipment.
- Motor vehicles and their parts that can no longer be used.

### HARMFUL TOXIC WASTE

Harmful toxic waste is all waste containing or contaminated by substances listed in the annex to the Italian Presidential Decree 915/52 implementing directives 75/442/EEC, 76/442/EEC, 76/403/EEC, 768/319/EEC.

Following are described the types of waste that may be generated during the lifetime of an air handling unit:

- Cell filters from the suction unit.
- Waste oils and greases from lubricating the fan motor assembly.
- Rags or paper soaked with substances used for the cleaning of the various parts of the machine.
- Residues from cleaning the panelling.



Waste from the cell filters are to be handled as special waste or harmful toxic depending on their use, the sector and the environment in which they are used.

Waste and scraps may cause irreparable damage if dispersed in the environment.

### ELECTRICAL/ELECTRONIC WASTE

Under art. 13 of Italian Legislative Decree no. 49 of 2014 "Implementation of the WEEE Directive 2012/19/EU on electrical and electronic equipment waste".



The logo with the crossed-out bin specifies that the product has been placed on the market after 13 August 2005 and that at the end of its useful life it should not be disposed of with other waste but rather must be collected separately. All equipment is made from recyclable metallic materials (stainless steel, iron, aluminium, galvanised steel, copper, etc.) in a percentage higher than 90% by weight. Before disposal make the equipment unusable by removing the power cord and closing any devices for closing compartments or cavities (where present). It is necessary to pay attention to the management of this product at the end of its life by reducing its negative impact on the environment and improving the effective use of resources, applying the principles of "he who pollutes pays", prevention, preparation for reuse, recycling and recovery. Remember that the illegal or improper disposal of the product may result in the application of sanctions provided for by current provisions of law.

#### Disposal in Italy

In Italy WEEE equipment must be delivered:

- To Collection Centres (also called ecological islands or ecological platforms).
- To the dealer from whom the new equipment was purchased, which is required to collect it free of charge ("one to one" withdrawal).

#### Disposal in countries of the European Union

The EU Directive on WEEE equipment has been implemented differently by each country, so to dispose of this equipment we suggest contacting local authorities or the dealer to ask for the correct method of disposal.

# Diagnostics

## General diagnostics

The machine's electrical system includes quality electromechanical components and is therefore extremely durable and reliable over time.

Should there be any malfunctions due to malfunctions of electrical components it will be necessary to act as follows:

- Check the fuses of the power supply for the control circuits and if necessary replace them with fuses having the same specifications.
- Check if the thermal protection switch for the motor has been triggered or if its fuses have blown.

If this has occurred, it may be caused by:

- Motor overload due to mechanical problems. They need to be solved.
- Incorrect supply voltage. Verify the protection trip threshold.
- Malfunction and/or short circuits in the motor. Identify and replace the failed component.

## Electrical maintenance

The machine does not require routine maintenance repairs.

Do not modify the machine for any reason and do not add other devices.

The manufacturer is not liable for resulting malfunctions and problems.

Further clarification is available by contacting the manufacturer's Customer Service.

## Service

As for the maximum exploitation of the performance provided by the machine and extraordinary maintenance operations, this manual does not replace the experience of trained and qualified installers, users and maintenance personnel.

In this case, DAIKIN APPLIED EUROPE S.P.A. Technical Service provides:

- telephone support regarding the characteristics and the simplest interventions that can be performed on the machine;
- dispatch of documentary material;
- training of the User's staff assigned to the MACHINE (only on request);
- interventions to modify the machine (only on request).

# Troubleshooting table

MALFUNCTION TYPE	COMPONENT	POSSIBLE CAUSE	SOLUTION
NOISE	Fan impeller	Impeller deformed, unbalanced or loose	Impeller replacement or adjustment
		Nozzle damaged	Replacement or adjustment of the nozzle
		Foreign bodies in the fan	Removal
		Motor or fan not attached well	Improved fastening or component replacement
	Bearings	Bearing worn or deteriorated	component replacement
	Motor	Incorrect supply voltage	Supply voltage change
		Worn bearings	component replacement
		Contact between the rotor and stator	component replacement
Ducts	Excessive speed in the ducts	Check of the fan operation and pressure drops in the circuit and in the ducts	
	Anti-vibration joint too taut	Joint adjustment	
INSUFFICIENT AIR FLOW	Ducts and circuit	Load losses superior to the demand	Check of the pressure drops in accordance with the project data.
		Obstructions in the ducts	Cleaning
	Filters	too dirty	Cleaning
	Inverter	Incorrect setting	Check of the working parameters comparing them with the project
	Pulleys	Transmission error	Check of the pulleys installed in compliance with the project data, both on the motor and the fan.
	Heat exchange coils	too dirty	Cleaning
	Fan	Fan malfunction	Check of the impeller rotation, suction and delivery obstructions
EXCESSIVE AIR FLOW	Circuit/ducts	Load losses inferior to the demand	Check of the total static pressure in compliance with the project data.
	Inverter	Incorrect setting	Check of the inverter working parameters comparing them with the project
	Pulleys	Transmission error	Check of the pulleys installed in compliance with the project data, both on the motor and the fan.

INSUFFICIENT THERMAL EFFICIENCY	Heat exchange coil	Water side	-Check the connection of the inlet and outlet pipes to the coil is correct. -Check the temperature of the water entering and leaving the battery which must be in accordance with the project data is correct -Check the water flow rate in the coil in accordance with the project data. -Check the opening and operation of the regulating valves are correct.
		Air side	-Check the air flow that passes through the coil, in accordance with the project data. -Check the coil (no obstruction upstream or downstream).
		Adjustment	-Check the correct operation and calibration of probes, thermostats and thermometers. -Check the positioning of the control probes and coil operation are correct.
		Excessive air flow	Action on the fans
	Electric heaters	Incorrect wiring	Check the connection
		Thermostat not working	Check the calibration of the safety limit thermostat which must not exceed 40°C.
		Adjustment problems	Check the correct positioning and operation of the temperature probes.
	Coil water pump	Insufficient water flow	
		insufficient pressure	
		Wrong direction of rotation	
	Fluid	Temperature different from the project	
		Incorrect regulation bodies	
	WATER LEAK	Heat exchange coil	Dragging of drops due to high air velocity
Fan section		Clogged "overflow" drain	
		Siphon connected incorrectly	

THE UNDERPRESSURE NETWORK STEAM HUMIDIFIER DOES NOT WORK PROPERLY	Distributors	The valve blocks do not deliver pressure	<p>Check the following situations:</p> <ul style="list-style-type: none"> <li>- Actuator fitted or connected incorrectly.</li> <li>- Set point or control limit value too low.</li> <li>-Incorrect connection between control signal and actuator.</li> <li>-Safety chain with dedicated devices interrupted.</li> <li>-Maximum hygrometer positioned incorrectly.</li> <li>-Ceramic rotary disc valve locked in closed position.</li> <li>-Actuator or rotary valve blocked.</li> <li>-Lack of control signal or steam pressure.</li> </ul>
		The steam valve blocks discharge water	<p>Check the following situations:</p> <ul style="list-style-type: none"> <li>-The steam supply is not isolated.</li> <li>-The steam supply is not adequately drained.</li> <li>-The steam supply is not properly connected.</li> <li>-Excessive primary steam supply pressure.</li> <li>-Faulty or blocked secondary condensate drain.</li> </ul>
	Steam supply	Steam supply malfunction	<p>Check the following situations:</p> <ul style="list-style-type: none"> <li>-Shut-off damper on the supply line closed (read the pressure gauge).</li> <li>-Supply line clogged with impurities.</li> <li>-safety valve closed upstream</li> </ul>
	Valve	Ceramic disc rotary valve not closed	<p>Check the following situations:</p> <ul style="list-style-type: none"> <li>-Actuator fitted or connected incorrectly.</li> <li>-Controller faulty or incorrectly set.</li> <li>-Defective actuator.</li> <li>-Rotary ceramic disc valve locked open.</li> <li>-The holding spring from the ceramic discs has lost clamping force.</li> </ul>
THE PLATE RECUPERATOR DOES NOT WORK	Dampers	Incorrect position	Check the dampers: suitable position for the correct air flow through the recuperator.
	Air flow	Incorrect air flow rates	Check that the air flow rates passing through the recuperator are in accordance with the project data.
	High pressure drop	Dirty recuperator	Check for obstructions
THE ROTARY RECUPERATOR DOES NOT WORK	Wheel	Incorrect sense of rotation	
	Belt	Transmission problems	Check the assembly of the drive belt.
	Motor	Rotation problems	Check the correct operation and positioning of the motor.
	High pressure drops	Dirty recuperator	Check for obstructions





# Repair log

DATE	SERVICE TYPE	TIME REQUIRED	SIGNATURE





**DAIKIN APPLIED EUROPE S.p.A.** Via Piani S. Maria, 72 - 00072 Ariccia (Rome) Italy - [www.daikinapplied.eu](http://www.daikinapplied.eu)



This publication is drawn up only as a technical support and does not constitute a binding commitment for Daikin Applied Europe S.p.A. Daikin Applied Europe S.p.A. has drawn up the content to the best of its ability. No explicit or implicit guarantee is given as to the completeness, precision or reliability of its content. All the data and specifications contained herein are subject to change without notice. The data stated at the time of the order prevail. Daikin Applied Europe S.p.A. accepts no liability whatsoever for any direct or indirect damage, in the broadest sense of the word, deriving from or associated with the use and/or interpretation of this publication.  
All content is protected by the copyright of Daikin Applied Europe S.p.A.

D-EIMAH00105-15\_02EN